

MARK: _____

PROJECT: _____

DATE: _____



**Centrifugal Plenum Fan
 Arrangement 4
 Direct Drive
 Class I-III**

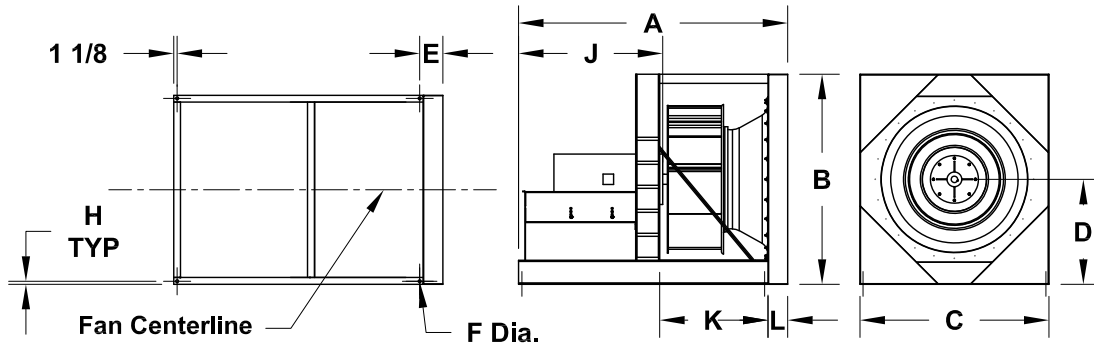

FOR REDUCED WIDTH WHEELS
 $A^{\circ} = A - (\text{UNIT SIZE} \times .03615 \times \text{PERCENT REDUCED})$
 $K^{\circ} = K - (\text{UNIT SIZE} \times .03615 \times \text{PERCENT REDUCED})$

FOR INCREASED WIDTH WHEELS
 $A^{\circ} = A + (\text{UNIT SIZE} \times .03615 \times \text{PERCENT INCREASED})$
 $K^{\circ} = K + (\text{UNIT SIZE} \times .03615 \times \text{PERCENT INCREASED})$

EXAMPLE: SIZE 402 REDUCED 10%

$A^{\circ} = 76 - (402 \times .03615 \times .10)$

$A^{\circ} = 76 - (1.453)$

$A^{\circ} = 74.547$

DIMENSION DATA

Size	A	B	C	D	E	F	H	J	K	L	Max Mtr Frame	RPM Max.	Channel Size	Approx. Ship Wt.
150	29-27/32	21-1/2	21-1/2	10-3/4	3-3/16	5/8	23/32	17-1/2	11-7/16	2-1/16	145	1770	C4x5.4	110
165	32-7/16	23-3/4	23-3/4	11-7/8	3-3/16	5/8	23/32	18-7/8	12-5/8	2-1/16	182	1770	C4x5.4	130
180	34-17/32	25-3/4	25-3/4	12-7/8	4-3/16	5/8	23/32	18-7/8	13-3/4	3-1/16	184	1770	C4x5.4	215
195	35-21/32	28	28	14	4-3/16	5/8	23/32	18-7/8	14-7/8	3-1/16	184	1770	C4x5.4	240
210	40-3/8	30	30	15	4-3/16	5/8	23/32	22-1/2	15-15/16	3-1/16	213	1770	C4x5.4	260
225	41-3/8	32-1/4	32-1/4	16-1/8	4-3/16	5/8	23/32	22-1/2	16-15/16	3-1/16	215	1770	C4x5.4	290
245	48-1/8	35	35	17-1/2	4-3/16	5/8	23/32	27-3/4	18-3/8	3-1/16	256	1770	C4x5.4	320
270	53-5/16	38-3/4	38-3/4	19-3/8	4-11/16	5/8	23/32	30-5/8	20-5/16	3-9/16	286	1770	C4x5.4	350
300	58-13/32	43	43	21-1/2	4-11/16	5/8	23/32	33-5/8	22-3/8	3-9/16	324	1770	C4x5.4	450
330	61-27/32	49-1/2	46	23-5/8	5-11/16	15/16	25/32	33-7/8	24-5/8	4-9/16	326	1770	C5x6.7	540
365	72-19/32	53-1/2	49	26-1/8	5-11/16	15/16	27/32	42-1/8	27	4-9/16	364	1170	C6x10.5	710
402	76	60	54	28-3/4	6-3/16	15/16	27/32	42-1/8	29-7/8	5-1/8	404	1170	C6x10.5	940
445	79-31/32	64	58-1/2	31-7/8	7-3/16	15/16	27/32	42-1/8	32-7/8	6-1/8	405	1170	C6x10.5	1300
490	89-11/16	70	63	35	7-11/16	15/16	1	48-1/8	36-1/8	6-9/16	444	1170	C8x11.5	1550
540	93-3/8	75	69	38-5/8	7-23/32	1-1/16	1	48-1/8	39-3/4	6-5/8	445	1170	C8x11.5	1850
600	98-1/4	82	75	42-7/8	8-7/32	1-1/16	1	48-1/8	44-1/8	7-1/8	445	870	C8x11.5	2360
660	104-3/8	90	82	47-1/4	9-7/32	1-1/16	7/8	48-7/8	48-9/16	8-1/8	445	870	MC8x18.7	3150
730	135-7/8	92	92	52-1/4	9-7/32	1-1/16	7/8	75-3/8	53-9/16	8-1/8	445	690	MC8x18.7	3966

ALL DIMENSIONS IN INCHES. WEIGHTS IN LBS., LESS MOTOR, BASED ON 100% WIDE CLASS 3 STEEL WHEEL.