



**COOK**

# Isolation Damper

DATE: \_\_\_\_\_

PROJECT: \_\_\_\_\_

LOCATION: \_\_\_\_\_

Accessory Data Sheet  
Isolation Damper  
Low Leakage Class 1A Rated  
for QMX Mixing Box  
**Aluminum**

**STANDARD CONSTRUCTION FEATURES:**

- Frame: 5" x 1" x 6063T5 extruded hat channel with .125" minimum wall thickness
- Blades: 6" wide, 6063T5 heavy gauge extruded aluminum, airfoil shape. Opposed blade standard.
- Seals: Synthetic polymer blade edge seals and flexible SS compressible jamb seals.
- Bearings: Molded synthetic.
- Linkage: Concealed in frame.
- Axles: 1/2" plated steel hex.
- Temperature Limits: -72°F and +275°F.
- Actuator out of Airstream, 1 Actuator per panel, protected from weather.
- Sizes 90-202 available in 115v (230, 460, and 575vac with transformer)
- Sizes 225-600 available in 24-124vdc or 24-230vac (460 and 575vac with transformer)
- Power Open/Spring Close (Reversible).
- Finish: Air-dry enamel coating to match fan color.

**OPTIONAL CONSTRUCTION FEATURES:**

- Air-dry epoxy finish.
- Actuator by others, damper provided with manual hand quadrant.
- Pneumatic actuator.

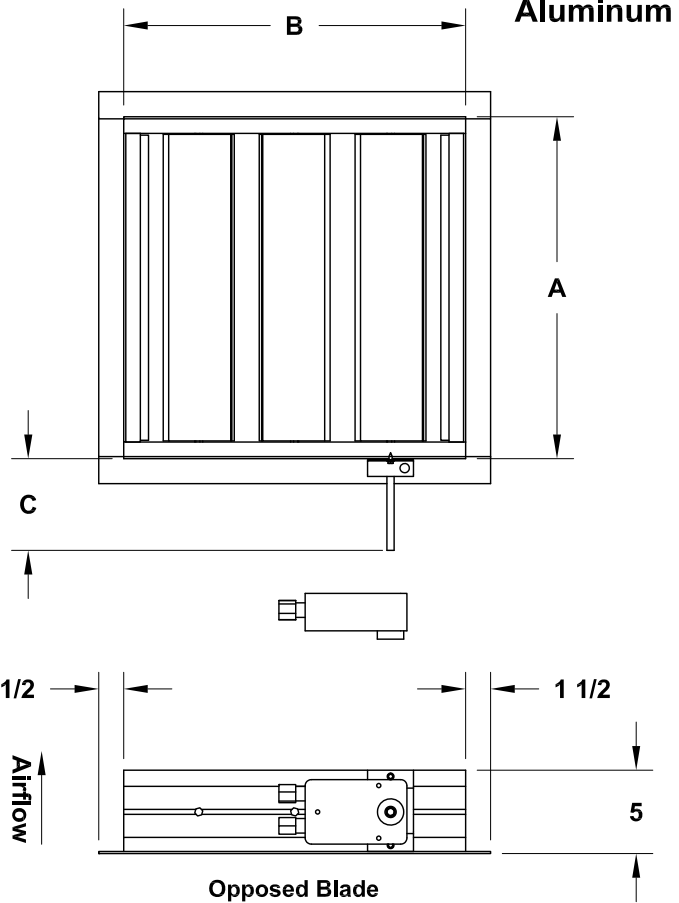
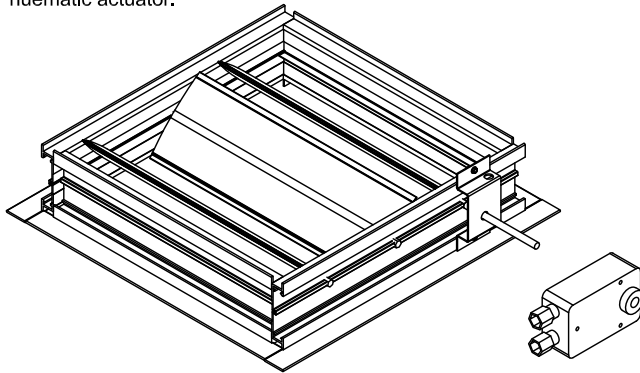

**DIMENSION DATA**

Qty	Mark	Size	A	B	C	No. Panels	Actuator Model	Unit Wt.
		90	24-1/2	18	6	1	LF120-S	19
		120	24-1/2	18	6	1	LF120-S	19
		135	24-1/2	18	6	1	LF120-S	19
		150	26-1/2	20	6	1	LF120-S	23
		165	28-1/2	22	6	1	LF120-S	26
		180	30-1/2	24	6	1	LF120-S	30
		202	34-1/2	26-1/2	6	1	LF120-S	36
		225	38-1/2	30	6	1	NFBUP-S	45
		245	40-1/2	32	6	1	NFBUP-S	50
		270	44-1/2	36	6	1	NFBUP-S	61
		300	48-1/2	40	6	1	NFBUP-S	73
		330	52-1/2	44	6	1	NFBUP-S	86
		365	58-1/2	50	6	1	NFBUP-S	108
		402	63-1/2	55	6	2	AFBUP-S	130
		445	70-1/2	59	6	2	AFBUP-S	154
		490	76-1/2	65	6	2	AFBUP-S	182
		540	83-1/2	72	6	2	AFBUP-S	219
		600	92-1/2	86	6	4	AFBUP-S	287

ALL DIMENSIONS IN INCHES. WEIGHTS IN LBS. WEIGHT INCLUDES ACTUATOR.

X0231R00