

DATE: _____
 PROJECT: _____
 LOCATION: _____

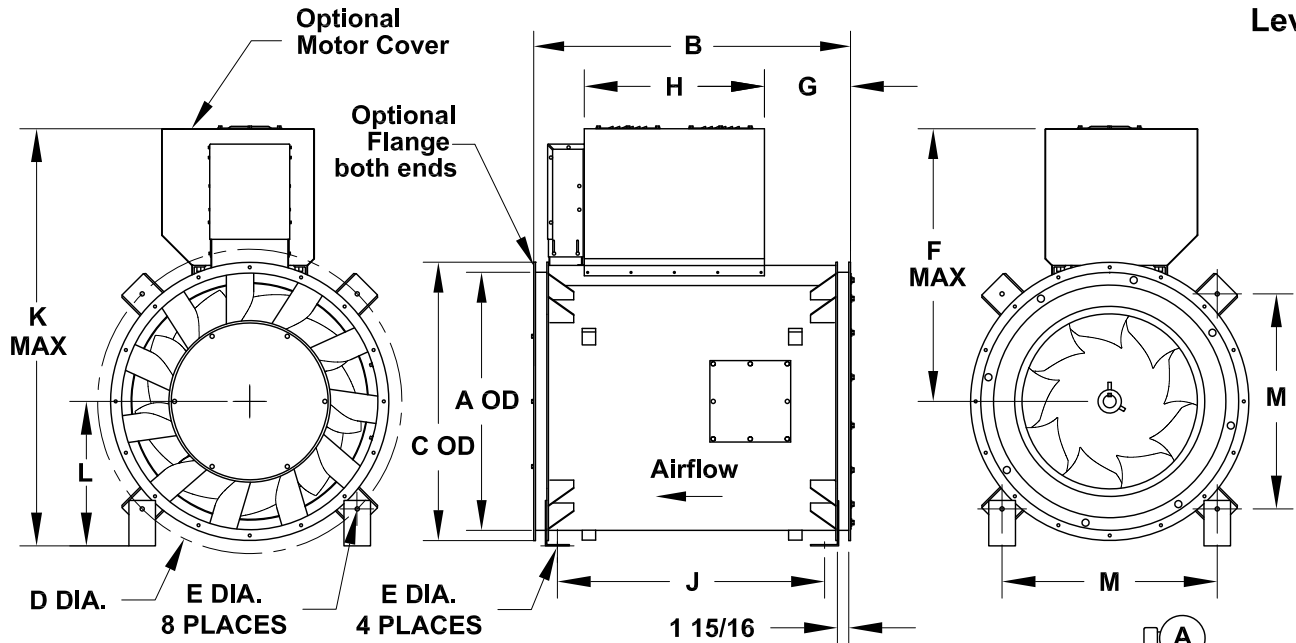

**Mixed Flow Inline
 Vertical/Horizontal Mount
 Belt Drive
 Arrangement 9
 Level 1**



STANDARD CONSTRUCTION FEATURES:

High efficiency mixed flow wheel - Continuously welded steel housing with Lorenized powder coating - Welded aerodynamic straightening vanes - Integral inlet and outlet collars for slip fit duct connections - Adjustable motor plate utilizing threaded studs for positive belt tensioning - Heavy duty ball or roller bearings with extended lube lines - Belt guard - Lifting lugs - Shaft locking collar.

**MOTOR POSITION CHART
 (View Facing Outlet)**

Mounting positions are field adjustable.

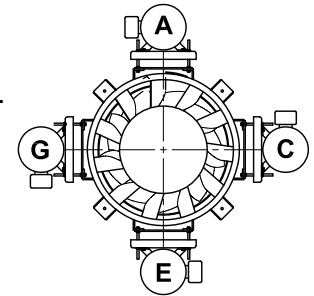

DIMENSION DATA

Size	A	B	C	D	E	F	G	H	J	K	L	M	Shaft Dia.	Max Mtr Frame	Approx. Unit Wt.
165	23-1/2	33	26-1/2	30-1/8	3/8	29-13/16	11-7/8	15-5/8	24-1/2	44-1/8	14-5/16	21-5/16	1	184T	276
180	25-5/8	35	28-5/8	32-5/16	3/8	31-3/8	9-3/8	19-3/8	26-7/8	46-7/8	15-1/2	22-7/8	1	215T	323
202	28-3/4	37-1/2	31-3/4	35-1/2	3/8	32-13/16	12	19-3/8	28-7/8	50-1/16	17-1/4	25-1/8	1	215T	391
225	31-15/16	41	34-15/16	38-3/4	3/8	34-11/16	15-1/2	19-3/8	32-3/8	53-11/16	19	27-3/8	1-3/16	215T	495
245	34-3/4	44-1/2	37-3/4	41-9/16	3/8	37-7/8	14-3/16	23-3/4	35-7/8	58-3/8	20-1/2	29-7/16	1-3/16	256T	582
270	38-5/16	47	41-5/16	45-1/8	3/8	41-7/16	14-3/16	26-3/8	38-3/8	63-7/8	22-7/16	31-15/16	1-3/16	286T	667
300	42-1/2	54	45-1/2	49-3/8	3/8	43-3/4	20-7/8	26-3/8	45-3/8	68-1/2	24-3/4	34-15/16	1-7/16	286T	845
330	46-3/4	58-1/2	49-3/4	53-5/8	3/8	45-9/16	25-9/16	26-3/8	49-7/8	72-9/16	27	37-15/16	1-7/16	286T	1038
365	51-3/4	64	54-3/4	59-1/2	3/8	48-1/4	30-7/16	26-3/8	55-3/8	78-1/16	29-13/16	42-1/16	1-7/16	286T	1329
402	56-15/16	68-1/2	59-15/16	64-7/8	3/8	53-1/4	32-15/16	28-3/8	60	85-7/8	32-5/8	45-13/16	1-7/16	326T	1650
445	63-1/16	74	66-1/16	70-7/8	3/8	59-7/8	36-5/16	30-3/8	65-1/2	95-1/2	35-5/8	50-3/16	1-11/16	365T	2060
490	69-3/8	80-1/2	72-3/8	78-1/8	3/8	62-13/16	42-7/8	30-3/8	72	101-5/8	38-13/16	55-1/4	1-11/16	365T	2459
540	76-7/16	87	79-7/16	85-3/16	7/16	68-5/8	46-1/4	33-3/8	78-1/2	111	42-3/8	60-1/4	1-15/16	405T	2821
600	84-7/8	95-1/2	88	93-3/4	7/16	73-1/16	54-11/16	33-3/8	87-1/8	119-11/16	46-5/8	66-5/16	2-3/16	405T	3592

ALL DIMENSIONS IN INCHES. WEIGHTS IN LBS., LESS MOTOR.