



# COOK

# AFB-S

DATE: \_\_\_\_\_

PROJECT: \_\_\_\_\_

LOCATION: \_\_\_\_\_



**Tube Axial Fan**  
**Upblast Ceiling Mount**  
**Stainless Steel Construction**  
**Belt Drive/Arrangement 9**

### DIMENSION DATA

Size	A	B	C	D	E	F	G	H	J	K	L
12	12-7/8	15-11/16	14-5/8	12 Ga.	22	5/16	6	24-5/8	18-1/16	3/8	12-3/4
14	14-7/8	17-11/16	16-5/8	12 Ga.	22	5/16	6	25-5/8	20-1/16	3/8	14-3/16
16	16-7/8	19-11/16	18-5/8	12 Ga.	25	5/16 x 5/8	6	30-1/8	22-1/16	3/8	15-5/8
18	18-7/8	21-11/16	20-5/8	12 Ga.	25	5/16 x 5/8	6	31-1/8	24-1/16	3/8	17
20	20-7/8	23-11/16	22-3/8	12 Ga.	31	5/16 x 5/8	6	32-1/8	26-5/16	3/8	18-5/8
24	24-7/8	29-1/8	26-7/8	10 Ga.	31	7/16 x 3/4	6	39-7/8	30-13/16	3/8	21-3/4
28	28-7/8	33-1/8	30-7/8	10 Ga.	31	7/16 x 3/4	6	41-7/8	34-13/16	3/8	24-5/8
32	33	37-1/4	35	10 Ga.	34	7/16 x 3/4	6	45-1/4	39-15/16	7/16	28-1/4
36	37	41-3/8	39	10 Ga.	34	7/16 x 3/4	6	47-1/4	43-15/16	7/16	31-1/16

Size	ODP Max. Mtr. Frame	Ship Wt. less Mtr.
12	145T	88
14	182T	95
16	182T	123
18	184T	140
20	184T	173
24	213T	235
28	215T	269
32	254T	354
36	256T	393

ALL DIMENSIONS IN INCHES. WEIGHTS IN LBS.

### STANDARD CONSTRUCTION FEATURES:

All stainless steel construction – Stainless steel prop – Minimum 12 ga. 304 stainless steel housing – Extended lube lines – Regreasable bearings in cast pillow block housing – Shaft seal and slinger.

### ACCESSORIES

1. INLET/OUTLET GUARD
2. INLET/OUTLET COMPANION FLANGE
3. VIBRATION ISOLATORS
4. INLET BELL
5. INLET/OUTLET CONE
6. ACCESS DOOR
7. VANE SECTION
8. BELT GUARD
9. MOTOR COVER
10. BOMBAY DOORS

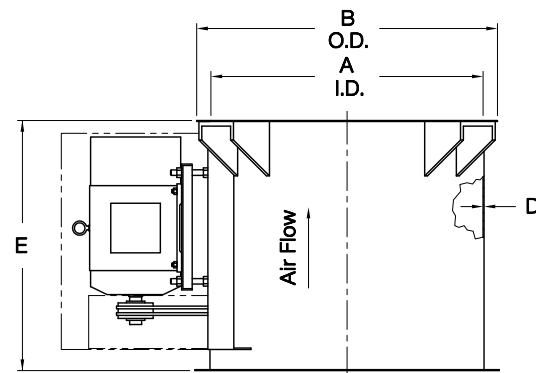
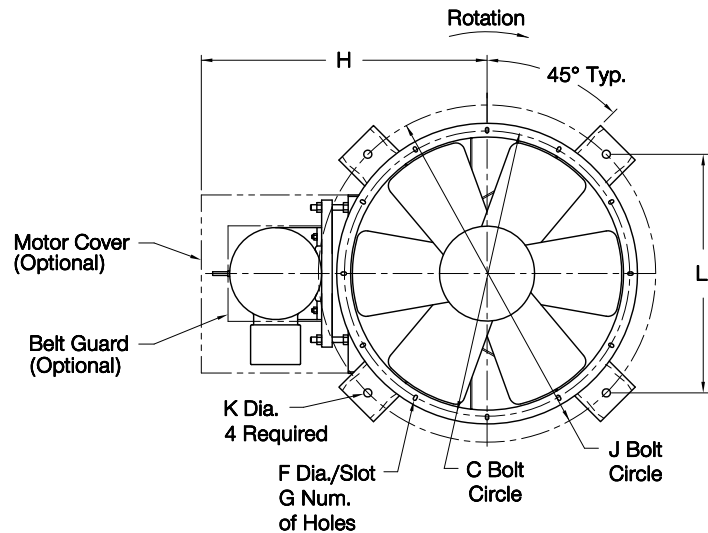

**LARGEST MOTOR SHIPPED MOUNTED:** ODP (OPEN DRIP-PROOF) 25 HP; 2 SP (2 SPEED) 20 HP; X-PRF (EXPLOSION PROOF) 20 HP; TEFC (TOTALLY ENCLOSED FAN COOLED) 20 HP.

VA062R02