

MARK: _____

PROJECT: _____

DATE: _____

Accessory Data Sheet
External Speed Control
Electronically Commutated (EC) Motor
Type M

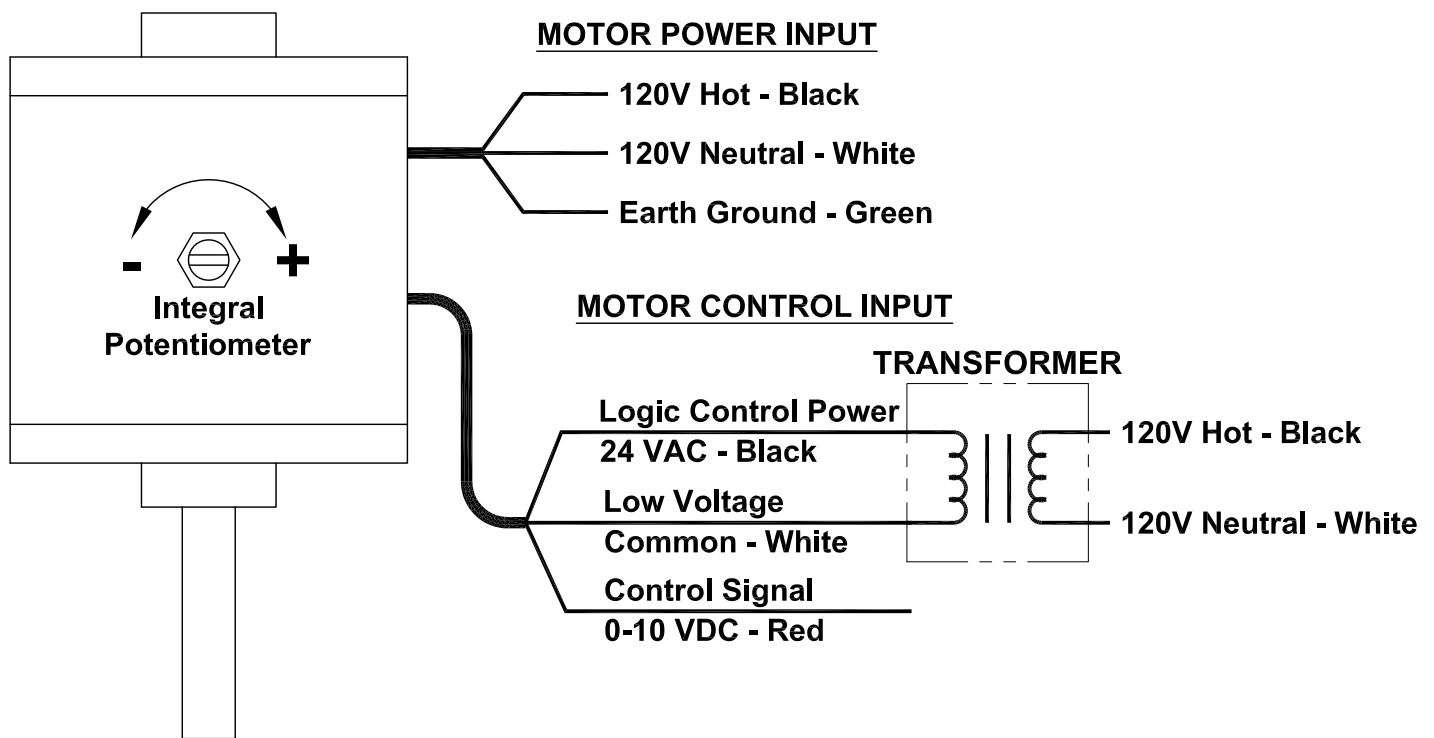

STANDARD CONSTRUCTION FEATURES:

External signal speed control requires a 0-10 VDC control signal to adjust speed of the motor as well as a 24 VAC power source to operate the motor control circuit (a 24v transformer is included and shipped loose with the fan)

- The motor will operate from 2-10 VDC and turns off when the control signal is below 1.9 VDC. Integral potentiometer must be set to full speed when using external speed control.