

This publication contains the installation, operation and maintenance procedures for standard units of the *HMD: Heated Makeup Direct*.



Carefully read this publication and any supplemental documents prior to any installation or maintenance procedure.

Loren Cook catalog, *Heated Makeup Air Unit*, provides additional information describing the equipment, fan performance, available accessories and specification data.

For additional safety information, refer to AMCA publication 410-96, *Safety Practices for Users and Installers of Industrial and Commercial Fans*.

All of the publications listed above can be obtained from Loren Cook Company by phoning (417) 869-6474, extension 166; by fax at (417) 832-9431; or by e-mail at info@lorencook.com.

For information and instructions on special equipment, contact Loren Cook Company at (417) 869-6474.

Receiving and Inspection

Carefully inspect the unit and accessories for any damage and shortage immediately upon receipt of the unit.

- Turn the blower by hand to ensure it turns freely and does not bind.
- Record on the Delivery Receipt any visible sign of damage.

Handling

Lift unit fans by the lifting eyes.

NOTICE! Never lift by the housing.

Storage

If the fan is stored for any length of time prior to installation, store it in its original shipping crate and protect it from dust, debris and the weather.

Rotate the wheel several revolutions every three to five days to keep a coating of grease on all internal bearing parts.

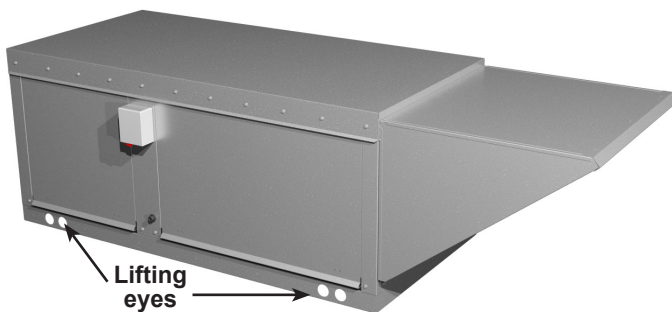

!WARNING

Rotating Parts & Electrical Shock Hazard:

Fans should be installed and serviced by qualified personnel only.

Disconnect electric power before working on unit (prior to removal of guards or entry into access doors).

Follow proper lockout/tagout procedures to ensure the unit cannot be energized while being installed or serviced.

A disconnect switch should be placed near the fan in order that the power can be swiftly cut off, in case of an emergency and in order that maintenance personnel are provided complete control of the power source.

Grounding is required. All field-installed wiring must be completed by qualified personnel. All field installed wiring must comply with National Electric Code (NFPA 70) and all applicable local codes.

Fans and blowers create pressure at the discharge and vacuum at the inlet. This may cause objects to get pulled into the unit and objects to be propelled rapidly from the discharge. The discharge should always be directed in a safe direction and inlets should not be left unguarded. Any object pulled into the inlet will become a projectile capable of causing serious injury or death.

When air is allowed to move through a non-powered fan, the impeller can rotate, which is referred to as windmilling. Windmilling will cause hazardous conditions due to unexpected rotation of components. Impellers should be blocked in position or air passages blocked to prevent draft when working on fans.

Friction and power loss inside rotating components will cause them to be a potential burn hazard. All components should be approached with caution and/or allowed to cool before contacting them for maintenance.

Under certain lighting conditions, rotating components may appear stationary. Components should be verified to be stationary in a safe manner, before they come into contact with personnel, tools or clothing.

Failure to follow these instructions could result in death or serious injury.

The attachment of roof mounted fans to the roof curb as well as the attachment of roof curbs to the building structure must exceed the structural requirements based on the environmental loading derived from the applicable building code for the site. The local code official may require variations from the recognized code based on local data. The licensed engineer of record will be responsible for prescribing the correct attachment based on construction materials, code requirements and environmental effects specific to the installation.

⚠ WARNING

FOR YOUR SAFETY

Improper installation, adjustment, alteration, service or maintenance can cause property damage, injury or death. Read the installation, operating and maintenance instructions thoroughly before installing or servicing this equipment.

If you smell gas:

1. Open windows.
2. Don't touch electrical switches.
3. Extinguish any open flame.
4. Immediately call your gas supplier.

The use and storage of gasoline or other flammable vapors and liquids in open containers in the vicinity of this appliance is hazardous.

Fire Or Explosion Hazard

Installation and service must be performed by a qualified installer, service agency or gas supplier.

Intake Air

If HMD unit is used for make-up air for any type of fuel burning equipment, HMD unit must NOT be primary source of intake air. Consult fuel burning equipment manufacture for requirements and recommendations.

Environmental Hazards

Other considerations may be required if high winds or seismic activity are present. If more information is needed, contact a licensed professional engineer before moving forward.

Improper installation, adjustment, alteration, service or maintenance can cause serious injury, death or property damage. Carefully read this publication and any supplemental documents prior to any installation or maintenance procedure.

Installation

Clearance to Combustible / Service Clearances

The minimum distance required between the heater and adjacent combustible surfaces is 42 inches (1066.8 mm), on the controls side of the unit, to ensure the adjacent surface's temperature does not exceed 90 degrees above the ambient temperature.

For specific dimensions, refer to the submittal drawing for the specific fan type.

Installation of the heater (1) in airplane hangars must be done in accordance with the Standard for Aircraft Hangars, ANSI/NFPA 409, and (2) public garages must be done in accordance with the Standard for Parking Structures, ANSI/NFPA 88A, or the Standard for Repair Garages, ANSI/NFPA 88B, and with CAN/CSA B149.1 Natural Gas and Propane Installation Codes.



NOTICE! Adequate building relief shall be provided so as to not over pressurize the building when the heating system is operating at its rated capacity. It should be noted that this can be accomplished by taking into account, through standard engineering methods, the structure's designed infiltration rate; by providing properly sized relief openings; or by interlocking a powered exhaust system; or by a combination of these methods.

NOTICE! All indoor and outdoor units require that the air to the heater is ducted directly from the outdoors. Recirculation of room air is not permitted.

NOTICE! The heater inlet shall be located in accordance with the applicable building code provisions for ventilation air.

NOTICE! Field constructed intake accessories should be properly designed to minimize the entry of snow and rain.

NOTICE! If in doubt regarding the application, consult the heater manufacturer.

Indoor Hanging Arrangement

1. Install threaded hangers from ceiling supports. When locating hangers, allow enough room to open access panel(s). Two nuts must be used on the end of each threaded hanger. Ceiling supports are not supplied.
2. Using sheet metal screws, attach the weatherhood/ thru-wall / filter section to the damper / burner section. The flange on the weatherhood / thru-wall / filter section should overlap the flange on the damper / burner section.
3. Raise the unit into place
4. Using two nuts per hanger, fasten the unit supports to the hangers under the unit. Appropriate unit supports, such as the optional hanging bracket kit or c-channel and angle iron (not included) should be used. Attach ductwork to unit using self-tapping screws

NOTICE! In order to prevent the unit from swinging and to provide a safe environment for service and maintenance, additional measures may be needed to secure the unit.

Hanging Mount Example

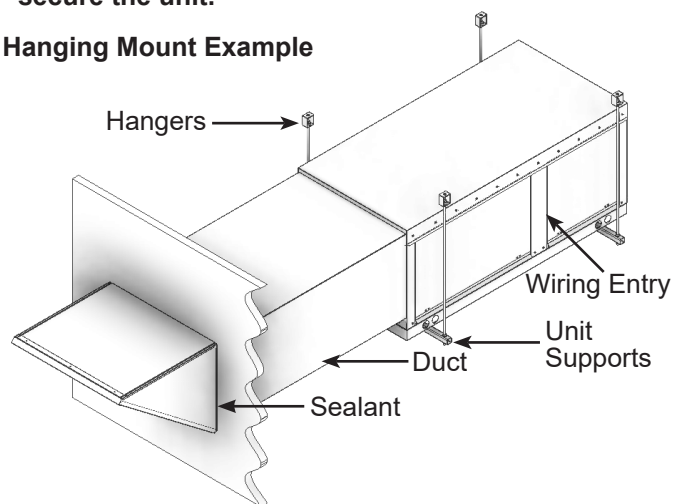

Good duct practices should be followed for all ductwork. Ductwork should be installed in accordance with SMACNA and AMCA guidelines, NFPA 96 and any local codes.



NOTICE! When a duct work system is attached to the inlet of the heater purge the volume of the duct system with at least four air changes prior to an ignition attempt.

5. Apply sealant around the perimeter of the weatherhood to prevent water penetration and drafts into the building.

Curb Arrangement

1. Position curb on the roof. Verify that unit supports are level, shim if necessary.
2. Attach curb to roof, flash in place
3. Attach ductwork to unit using self-tapping screws

Good duct practices should be followed for all ductwork. Ductwork should be installed in accordance with SMACNA and AMCA guidelines, NFPA 96 and any local codes.



4. Apply an appropriate sealant around the perimeter of the curb and duct adapter(s) to isolate fan vibration and prevent water penetration
5. Use the 4 lifting lugs to lift and place unit on the curb. A crane with a spreader bars is required.
6. **NOTICE! Do not include a wood nailer.** Use self-tapping sheet metal screws to fasten the unit to the curb support.
7. The weatherhood can now be assembled and attached to the unit.
8. Using an appropriate sealant, seal the seam between the weatherhood and the unit.

Curb Mount Example

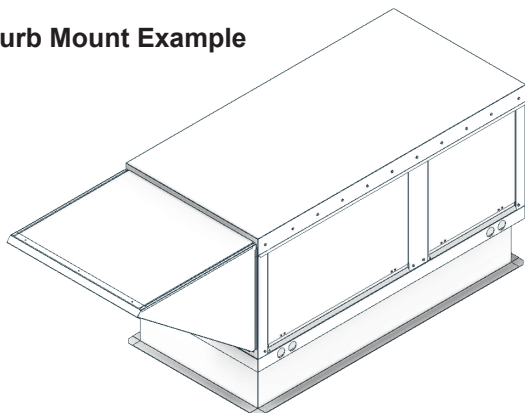

Wiring



In Canada, all wiring should be done in accordance with the Canadian Electrical Code.

NOTICE! The equipment must be properly grounded. Any wiring running through the unit in the airstream must be protected by metal conduit, metal clad cable or raceways.

NOTICE! If any of the original wire as supplied with the heater must be replaced, it must be replaced with type TW1 600v wire or its equivalent.

NOTICE! Field-wiring having a temperature rating of at least 105°C shall be used and supply circuit wiring shall have a minimum size of 14 AWG.

NOTICE! High voltage electrical input is needed for this equipment.

An electric disconnect switch having adequate ampacity (see marking on the heater for voltage and ampacity), if not provided as part of the heater, shall be installed in accordance with Article 430 of the National Electrical Code, ANSI/NFA 70.



WARNING

Custom Work:

Any wiring deviations may result in personal injury or property damage. Manufacturer is not responsible for any damage to, or failure of the unit caused by incorrect final wiring.

Manufacturer's standard control voltage is 120 VAC. Control wire resistance should not exceed 0.75 ohms (approximately 285 feet total length for 14 gauge wire; 455 feet total length for 12 gauge wire). If the resistance exceeds 0.75 ohms, an industrial-style plug-in relay should be wired in place of the remote switch. The relay must be rated for at least 5 amps and have a 120 VAC coil. Failure to comply with these guidelines may cause motor starters to chatter or not pull in, resulting in contactor failures and/or motor failures.

1. The unit's nameplate states the voltage and the unit's MCA. The main power lines to the unit should be sized accordingly. The nameplate is located on the outside of the unit on the control panel side.
2. Install field electrical wires through the provided holes.
3. Connect the main power lines to the disconnect switch and main grounding lug(s). Torque field connections to 20 in.-lbs.
4. Wire the optional convenience outlet. The convenience outlet requires a separate 115V power supply circuit. The circuit must include short circuit protection which may need to be supplied by others.

Single Phase

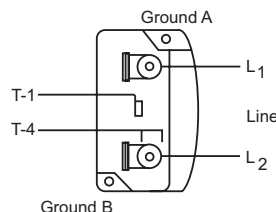

When ground is required, attach to ground A or B with no. 6 thread forming screw. To reverse, interchange T-1 and T-4.

Three Phase

3 Phase, 9 Lead Motor Y-Connection

Low Voltage
208/230 Volts

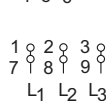

High Voltage
460 Volts

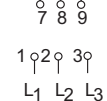

3 Phase, 9 Lead Motor Delta-Connection

Low Voltage
208/230 Volts

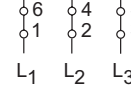

High Voltage
460 Volts

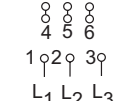

A complete wiring diagram is attached on the inside of the control center door(s). It is also available in the HMD Wiring Diagram Supplement.

Gas



All gas piping must be installed in accordance with local codes, or in the absence of local codes, in accordance with the National Fuel Gas Code, ANSI 2223.1/NFPA 54, or the CAN/CSA B149.1 Natural Gas and Propane Installation Code.

Do not connect the unit to gas types other than what is specified and do not connect the unit to gas pressures that are outside of the pressure range shown on the label.



When connecting the gas supply, the length of the run must be considered in determining the pipe size to avoid excessive pressure drop. Refer to a Gas Engineer's Handbook for gas pipe capacities.



Refer to the heater rating plate for determining the minimum gas supply pressure for obtaining the maximum gas capacity for which this heater is specified.

1. Determine the supply gas requirements by looking at the unit's nameplate on the outside of the unit on the control center side.
2. When the supply gas pressure exceeds the maximum gas pressure shown on the nameplate, an additional regulator (by others) is required to reduce the pressure. The regulator must have a listed leak limiting device or it must be vented to the outdoors. The regulator located inside the unit is used to adjust the unit's maximum output temperature.
3. If an optional vent line is located between the safety shutoff valves it must be piped to the outdoors.



Reference the National Fuel Gas Code for additional vent line requirements.

4. Test the system for leaks.

Operation

! WARNING

Pre Start-Up

Follow the pre start-up list before proceeding. Follow the procedure in the exact order that it is presented.

Failure to do so could result in serious injury or death and damage to equipment.

Pre Start-Up

General

1. Get voltage & amperage meter, thermometer, micro amp meter, u-tube manometer and tachometer.
2. Perform a gas leak check during heater start-up, to verify the gas tightness of the heater's components and piping under normal operating conditions.
3. Disconnect and lock-out all power and gas.

Blower

1. Check the housing, blower, and ductwork for any foreign objects before running the blower.
2. Rotate the fan wheel by hand and make sure no parts are rubbing. Check the V-belt drive for proper alignment and tension (a guide for proper belt tension and alignment is provided in the Belt Maintenance section).
3. Check fasteners, set screws and locking collars on the fan, bearings, drive, motor base, and accessories for tightness.

4. Compare the supplied voltage, hertz, and phase with the unit and motor's nameplate information.
5. Open the blower access door and run the blower momentarily to determine the rotation. Arrows are placed on the blower scroll to indicate the proper direction.

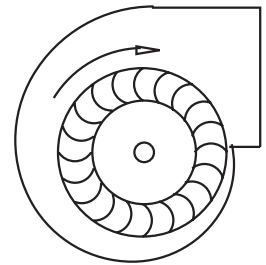

NOTICE! If the blower is rotating in the wrong direction, the unit will move some air, but will not perform as designed. Be sure to perform a visual inspection to guarantee the correct blower rotation.

- To reverse the rotation on three phase units, disconnect and lock-out the power, then interchange any two power leads.
 - To reverse the rotation on single phase units, disconnect and lock-out the power, then rewire the motor per the motor manufacturer's instructions.
6. Check for unusual noise, vibration or overheating of the bearings. Reference the Troubleshooting section for corrective actions. Excessive vibration may be experienced during the initial start-up. Left unchecked, it can cause a multitude of problems including structural and/or component failure. Generally, fan vibration and noise is transmitted to other parts of the building by the ductwork. To minimize this undesirable effect, the use of heavy canvas duct connectors is recommended.
 7. Measure the motor's voltage, amps and RPM. Compare to the specifications. Motor amps can be reduced by lowering the motor RPM or increasing system static pressure. Additional starters and overloads may be provided in the make-up air control center for optional exhaust blowers. Any additional overloads must be checked for proper voltage and amps.
 8. Measure the unit's air volume (cfm) and compare it with its rated air volume. If the measured air volume is wrong, adjust the fan's RPM by changing/adjusting the drive. The most accurate way to measure the air volume is by using a Pitot traverse method downstream of the blower. Changing the air volume can significantly increase the motor's amps. If the air volume is changed, the motor's amps must be checked to prevent overloading the motor. To ensure accuracy, the dampers are to be open when measuring the air volume.
 9. Adjust the settings on the optional components. See the Control Center Layout in the Reference section for location of optional components.
 - Heating Inlet Air Sensor:
Typical setting: 60-70°F
 - Building Freeze Protection:
Typical setting: 45°F
 - Dirty Filter Gauge:
Typical setting: Settings vary greatly for each unit.

Gas

1. Check the supply gas pressure and compare it with the unit's nameplate pressure requirements. Adjust the supply regulator as needed until the supply gas pressure is within the specified range (see below). The nameplate is located on the outside of the unit on the control panel side.
2. Check the settings on the optional high and low gas pressure switches. The high pressure setting is typically 8 inches wc (2 kPa) and the low pressure is setting is typically 3 inches wc (0.7 kPa). The switches are set at the factory and should not need adjustment. Adjust the setting only if needed. The purpose of the high and low gas pressure switches is to automatically shut down the burner if the inlet gas pressure is too low for the burner to safely light, or if the manifold pressure is too high for the burner to operate properly. Proper air velocity over the burner is critical on direct fired gas units. If the air velocity is not within the unit specifications, the unit will not operate efficiently, may have sporadic shutdowns, and may produce excessive carbon monoxide (CO) or other gases.

⚠ WARNING

Testing Inspection

All components of this or any other gas-fired heating unit must be leak tested prior to placing the unit into operation. The factory piping has been checked for leaks but should be rechecked due to shipping & installation issues. The field-installed shutoff valve should also be checked.

A soap & water solution should be used to perform this test.

Never test for gas leaks with a flame.

When leak testing pressures that are less than or equal to 14 in. wc (3.5 kPa), first close the field-installed shut-off valve to isolate the unit from gas supply line.

When leak testing pressures that are more than 14 in. wc (3.5 kPa), close the field-installed shutoff valve, disconnect the furnace & gas train from the gas supply line & plug the supply line before testing.

All piping should be clean & free of any foreign matter, which may damage the valves, regulators or burner.

Control Panel Parts

- | | | |
|-------------------------------|--------------------------------------|----------------------------|
| 1. Contactor | 7. Mild weather thermostat to damper | 15. Temperature controller |
| 2. Overload | 8. Damper motor | 16. Thermostat to blower |
| 3. Three phase transformer #A | 9. Terminal blocks | 17. Safety Shut off valve |
| 4. 120 - 24v transformer #B | 10. Circuit breaker | 18. Pressure gauge |
| 5. Ignition control | 11. Override switch* | 19. Gas valve |
| 6. High Temp Overload | 12. 120v spark ignitor | 20. Modulating gas valve |
| | 13. Pressure sensing probe (high) | 21. Pressure gauge |
| | 14. Pressure sensing probe (low) | 22. Safety Shut off valve |
| | | 23. Optional V.F.D. here |

*Turn ON to allow unit to have primary control. Turn OFF to allow Remote Display (RDU) to have primary control.

Control Panel

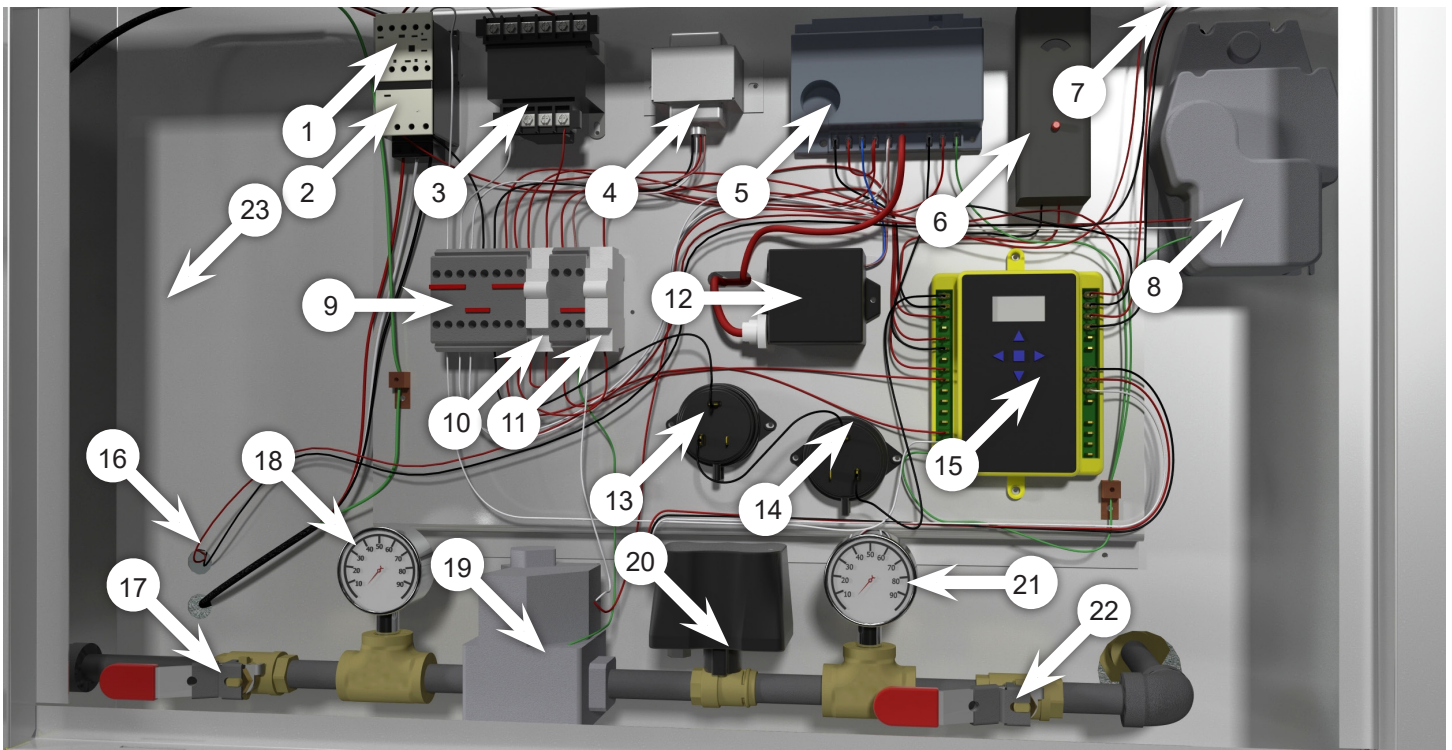

3. With all access panels in place, the fan running and discharging 70°F (21°C) air, connect a U-Tube manometer to the outer sensing probes and measure the static pressure across the burner. The proper static pressure should be (check *CFM / Static Pressure chart* on page 7). If needed, evenly adjust the baffles, keeping the burner centered in the opening until the required pressure is obtained. The pressure drop was set at the factory and may not need adjustment. When required pressure is obtained, be sure to reconnect the outer sensing probes. This process may need to be repeated until the proper pressure is achieved. This adjustment will change the air quantity delivered by the unit and therefore the air quantity delivered should be rechecked. Refer to the *Blower Start-Up* section.

- To increase static pressure decrease the opening.
- To decrease static pressure increase the opening.

4. Monitor the unit's actual temperature rise by placing a thermocouple in the unit's inlet and a second in the discharge, three duct diameters downstream of the burner. Send the unit to maximum flame by changing the rotation of the motor pack from left to right. Use a screw driver on top of modular gas valve. While monitoring the unit's temperature rise, set the maximum firing rate by adjusting the regulator until the designed temperature rise is achieved. After setting the maximum firing rate, reconnect the wire to the amplifier. Do not set the burner maximum firing rate based on gas pressure. It should be set based on the unit's designed temperature rise shown on the label. Setting the maximum firing rate during mild weather conditions may cause the high limit to trip out during extreme conditions requiring manual resetting. Gas trains are equipped with a combined regulator valve. Clockwise rotation increases the temperature rise; counterclockwise rotation decreases the temperature rise. The minimum setting for the maximum firing rate may be higher than required. This is acceptable, the burner will modulate as needed. To convert from Natural Gas to LP or vice versa follow the instructions associated with the high fire gas valve.

5. Set the operating temperature.

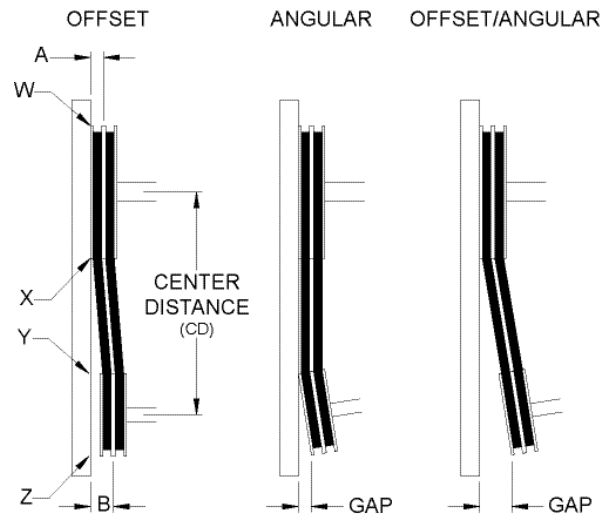

Tolerance	
Center Distance	Maximum Gap
Up thru 12"	1/16"
12" up through 48	1/8"
Over 48"	1/4"

NOTICE! Premature or frequent belt failures can be caused by improper belt tension, or misaligned sheaves. Abnormally high belt tension or drive misalignment will cause excessive bearing loads and may result in failure of the fan and/or motor bearings. Abnormally low belt tension will cause squealing on start-up, excessive belt flutter, slippage, and overheated sheaves.

1. V-belt drives must be checked on a regular basis for wear, tension, alignment, and dirt accumulation.
2. Check the tension by measuring the deflection in the belt as shown here.
3. Check the alignment by using a straight edge across both sheaves. The drawings below show where to measure the allowable gap for the drive alignment tolerance. All contact points (indicated by WXYZ) are to have a gap less than the tolerance shown in the table. When the pulleys are not the same width, the allowable gap must be adjusted by half of the difference in width.

Snow Accumulation

Clear snow away from roof mounted units. Keep the snow clear of the intake and access doors.

Motors

Motor maintenance is generally limited to cleaning and lubrication (where applicable). Cleaning should be limited to exterior surfaces only. Removing dust and grease buildup on the motor assures proper motor cooling.

Motors supplied with grease fittings should be greased in accordance with the manufacturer's recommendations. Greasing motors is only intended when fittings are provided. Many motors are permanently lubricated, requiring no additional lubrication.

NOTICE! Do not allow water or solvents to enter the motor or bearings. Motors and bearings should never be sprayed with steam, water or solvents.

Maintenance - All year

V-Belt Drives

NOTICE! Do not pry belts on or off the sheave. Loosen belt tension until belts can be removed by simply lifting the belts off the sheaves. When replacing V-belts on multiple groove drives, all belts should be changed to provide uniform drive loading. Do not install new belts on worn sheaves. If the sheaves have grooves worn in them, they must be replaced before new belts are installed.

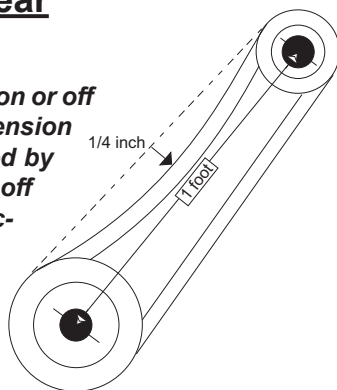

Relubrication Intervals

Service Conditions	NEMA Frame Size					
	Up to and including 184T		213T-365T		404T and larger	
	1800 RPM and less	Over 1800 RPM	1800 RPM and less	Over 1800 RPM	1800 RPM and less	Over 1800 RPM
Standard	3 yrs.	6 months	2 yrs.	6 months	1 yr.	3 months
Severe	1 yr.	3 months	1 yr.	3 months	6 months	1 months

Wheels

Wheels require little attention when moving clean air. Occasionally oil and dust may accumulate on the wheel causing imbalance. When this occurs the wheel and housing should be cleaned to assure proper operation.

Bearings

The bearings are carefully selected to match the maximum load and operating conditions of the specific fan size. The instructions provided in this manual and those provided by the bearing manufacturer will minimize any bearing problems.

Relubrication Intervals

RPM	Temp °F	Greasing Interval
Up to 1000	-30 to 120	6 months
	120 to 200	2 months
1000 to 3000	-30 to 120	3 months
	120 to 200	1 month
Over 3000	-30 to 120	1 month
	120 to 200	2 weeks
Any Speed	< -30	Consult Factory
Any Speed	> 200	1 week

Filter

Filter maintenance is generally limited to cleaning and replacement.

If aluminum mesh filters are installed, they can be washed in warm soapy water.

An adhesive spray can be added to aluminum mesh filters to increase their efficiency.

If disposable filters are installed, they can be checked by holding up to a light source. If light cannot pass through the filter, it should be replaced.

When reinstalling filters, be sure to install them with the airflow in the correct direction. An airflow direction arrow is located on the side of the filters.

Replacement filters should be from the same manufacturer and the same size as the original filters provided with the unit.

Maintenance - Beginning of season

Start-Up

Repeat the Blower Start-Up Step #5 and Direct Gas Start-Up Steps #1, #2 and #3. This will ensure that the gas and air are set properly before the heating season begins and should lead to trouble free operation all winter.

High Limit

The high limit switch may have tripped over the summer; it should be checked and reset if necessary.

Burner

Inspect the burner for accumulation of scales on both the upstream and downstream sides of the mixing plates. Any scaling or foreign material should be removed with a wire brush.

Visually check that all holes in the mixing plates are clear. If any burner ports are plugged (even partially), clear them with a piece of wire or another appropriate tool.

Do not enlarge burner ports when clearing a blockage, performance could be affected.

Replace or tighten any loose or missing fasteners on the mixing plates. Always use zinc plated or stainless steel fasteners.

Inspect and clean the flame and spark rod. Occasional replacement of the flame rod and spark rod may be necessary to ensure optimum unit performance.

Flame rods can last many years, but because of thermal expansion of the porcelain, flame rods can fail over time.

Gas Train

The gas connections, joints and valves should be checked annually for tightness. Apply a soap and water solution to all piping; watch for bubbling which indicates a leak. Other leak testing methods can be used.

CFM/Static Pressure Chart

Model #	Low CFM	Low SP	High CFM	High SP
2400	680	0.05	2400	0.94
3400	2000	0.2	3400	1
4100	3000	0.35	4100	1.1

Parts

To replace parts, contact a COOK representative.

Troubleshooting

Blower does not operate

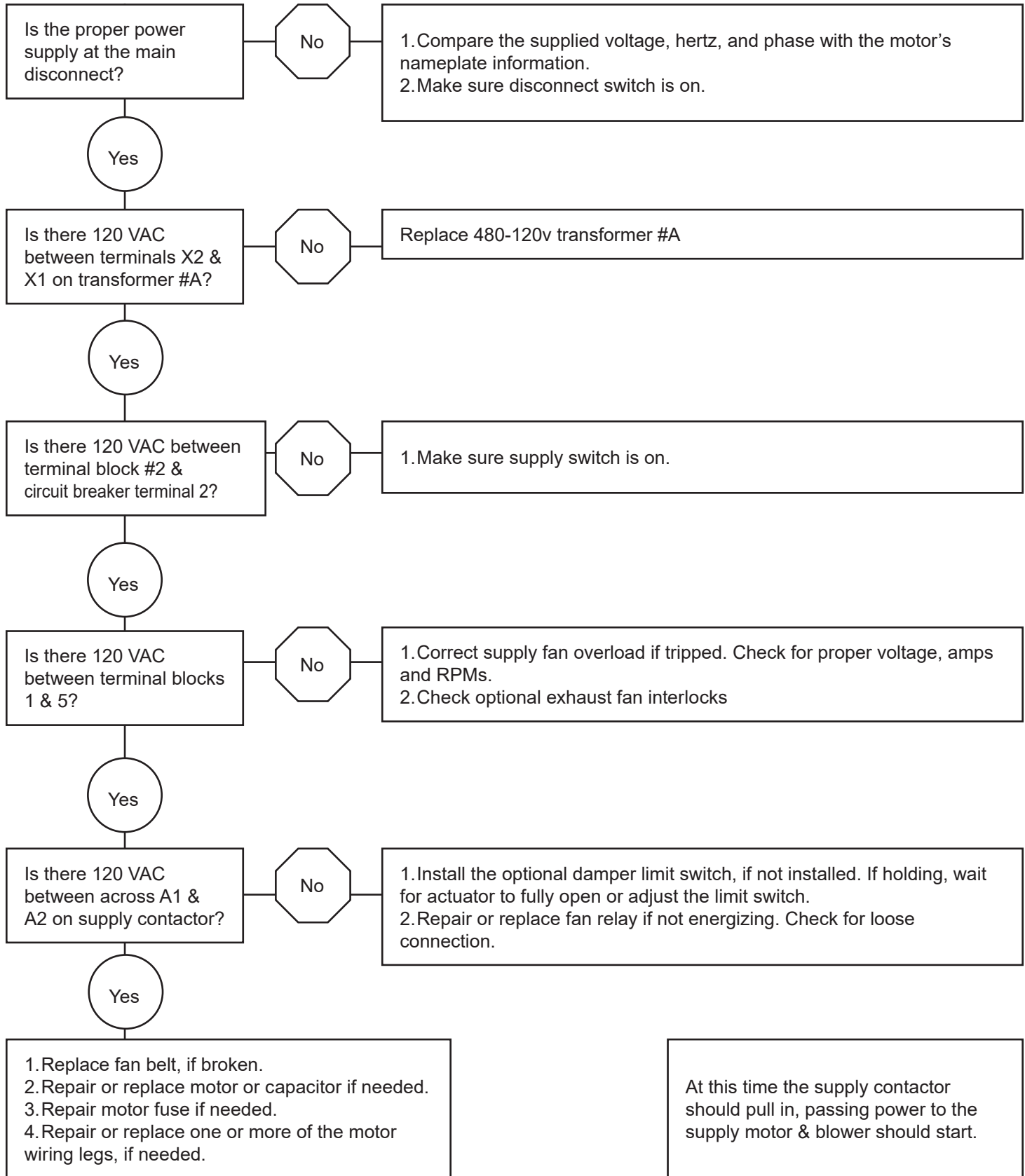

Refer to the control panel parts list when troubleshooting.

Troubleshooting

Motor overamps

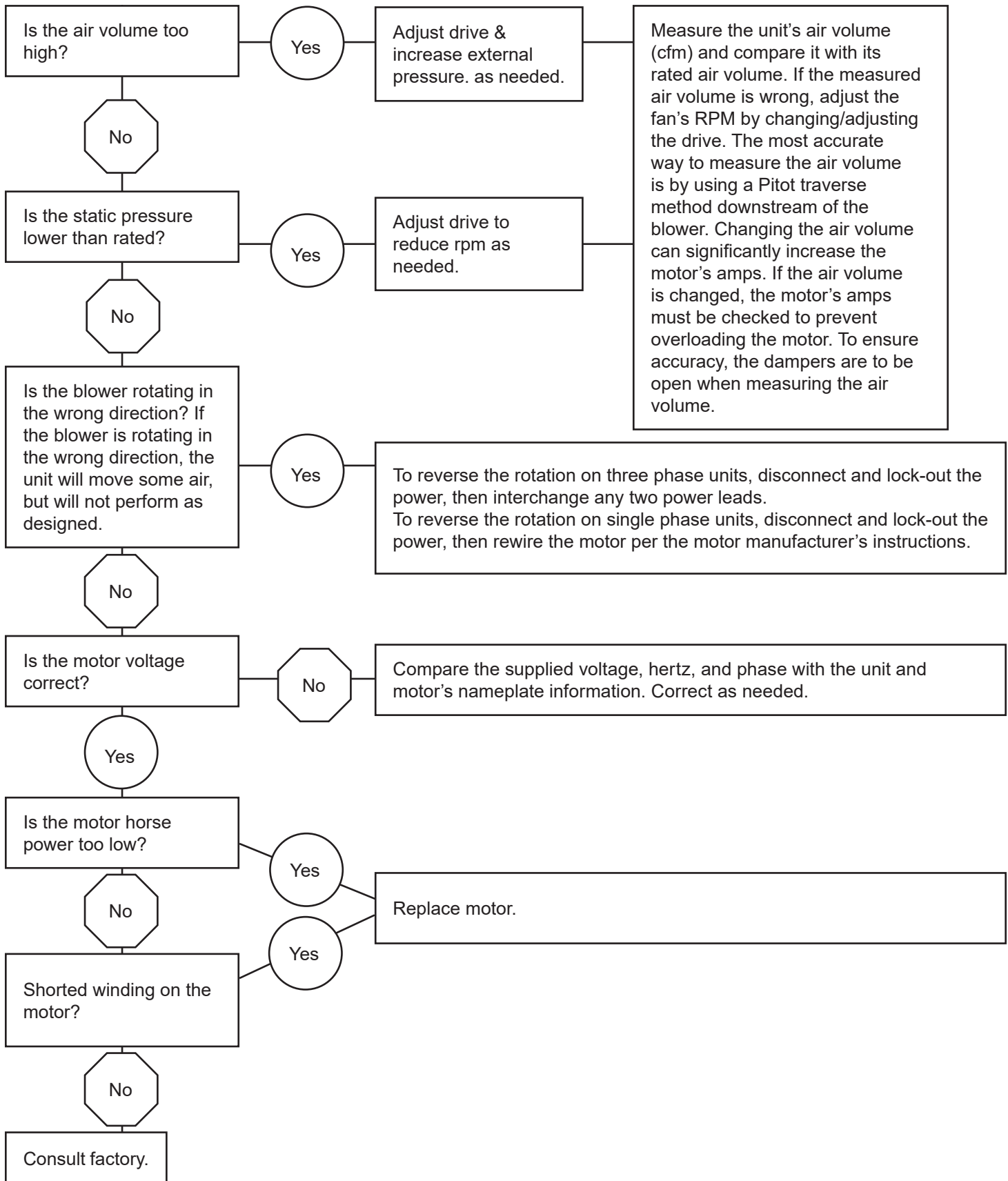

Refer to the control panel parts list when troubleshooting.

Troubleshooting

Insufficient airflow

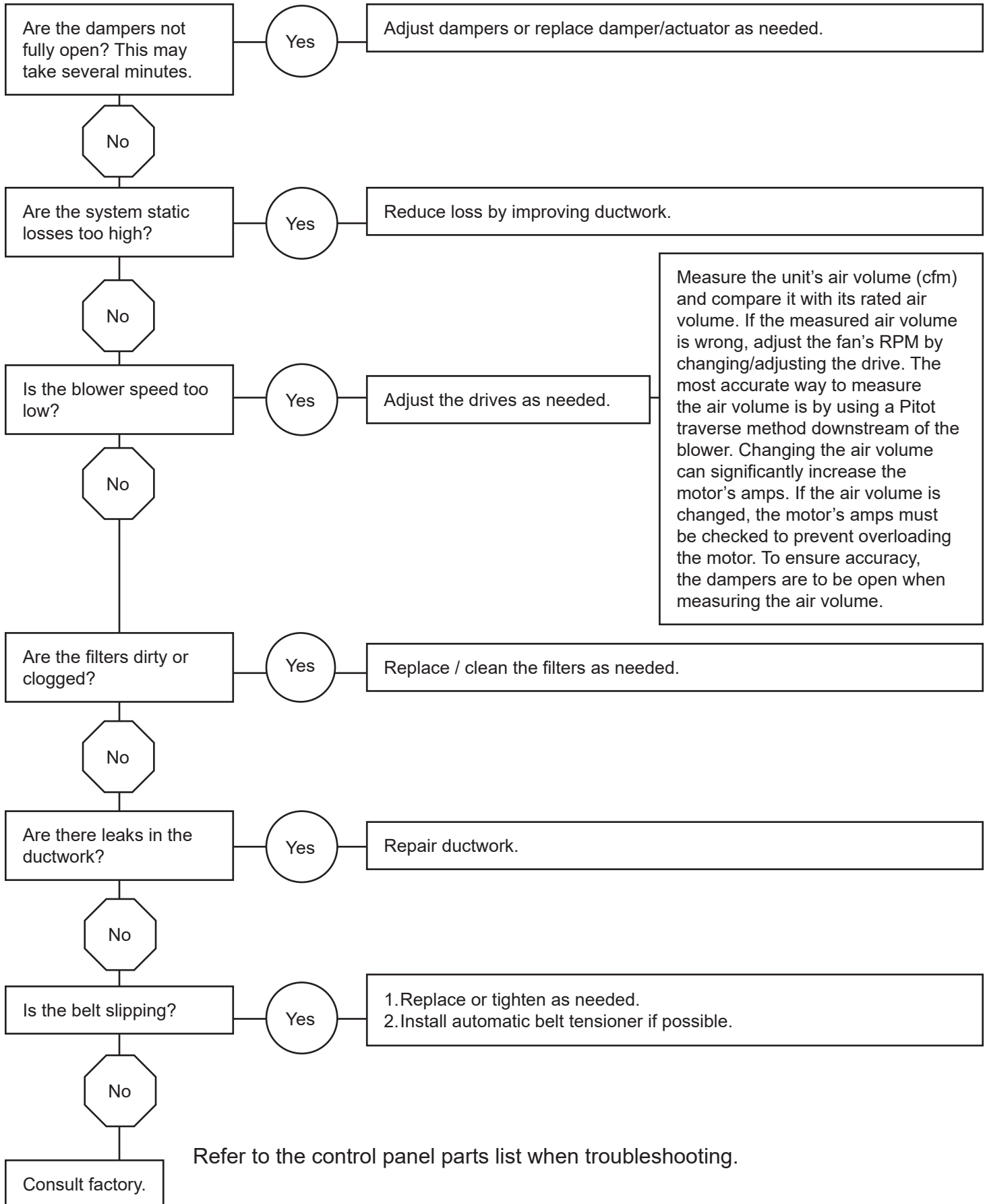

Troubleshooting

Too much airflow

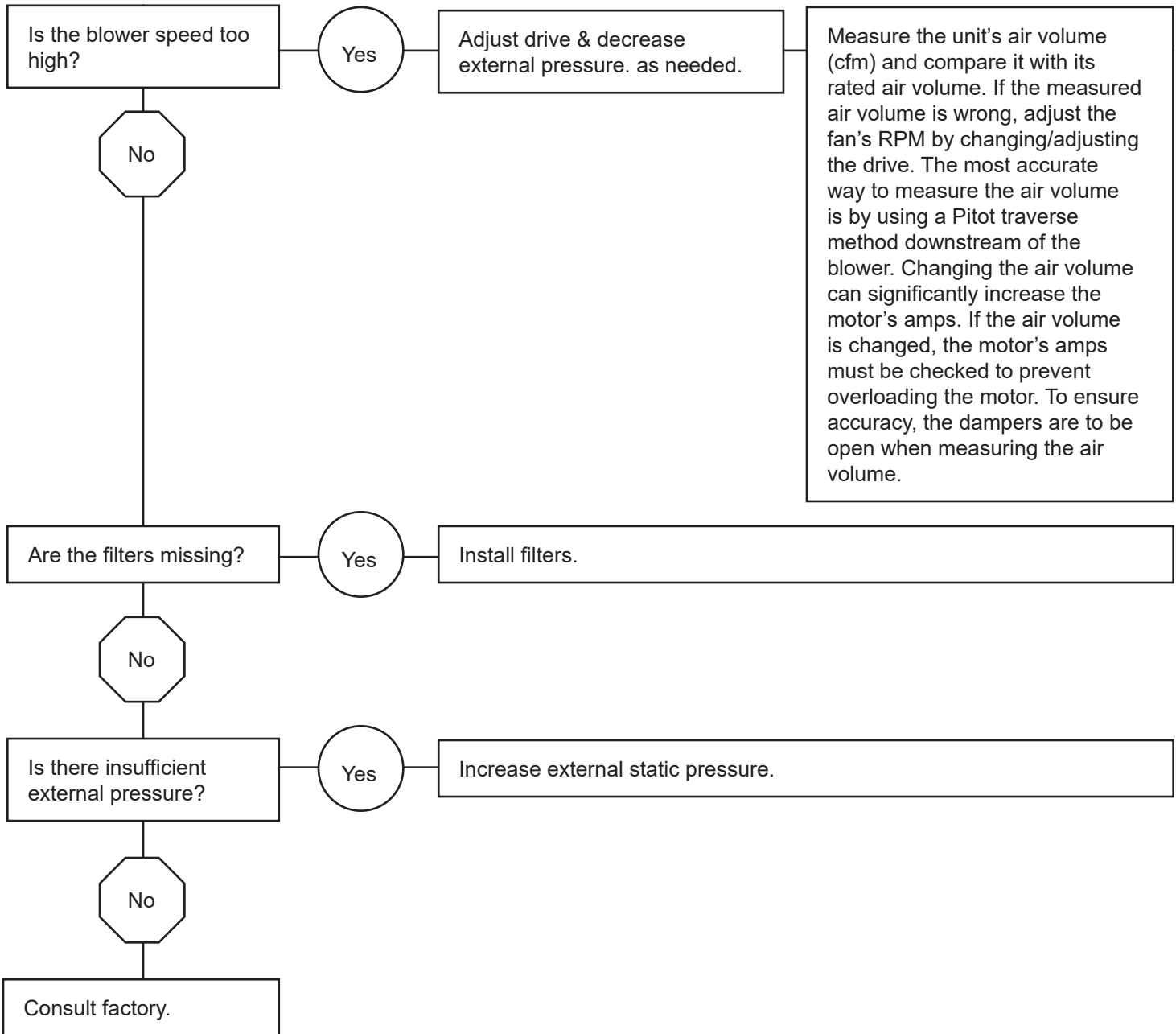

Refer to the control panel parts list when troubleshooting.

Troubleshooting

Excessive noise or vibration

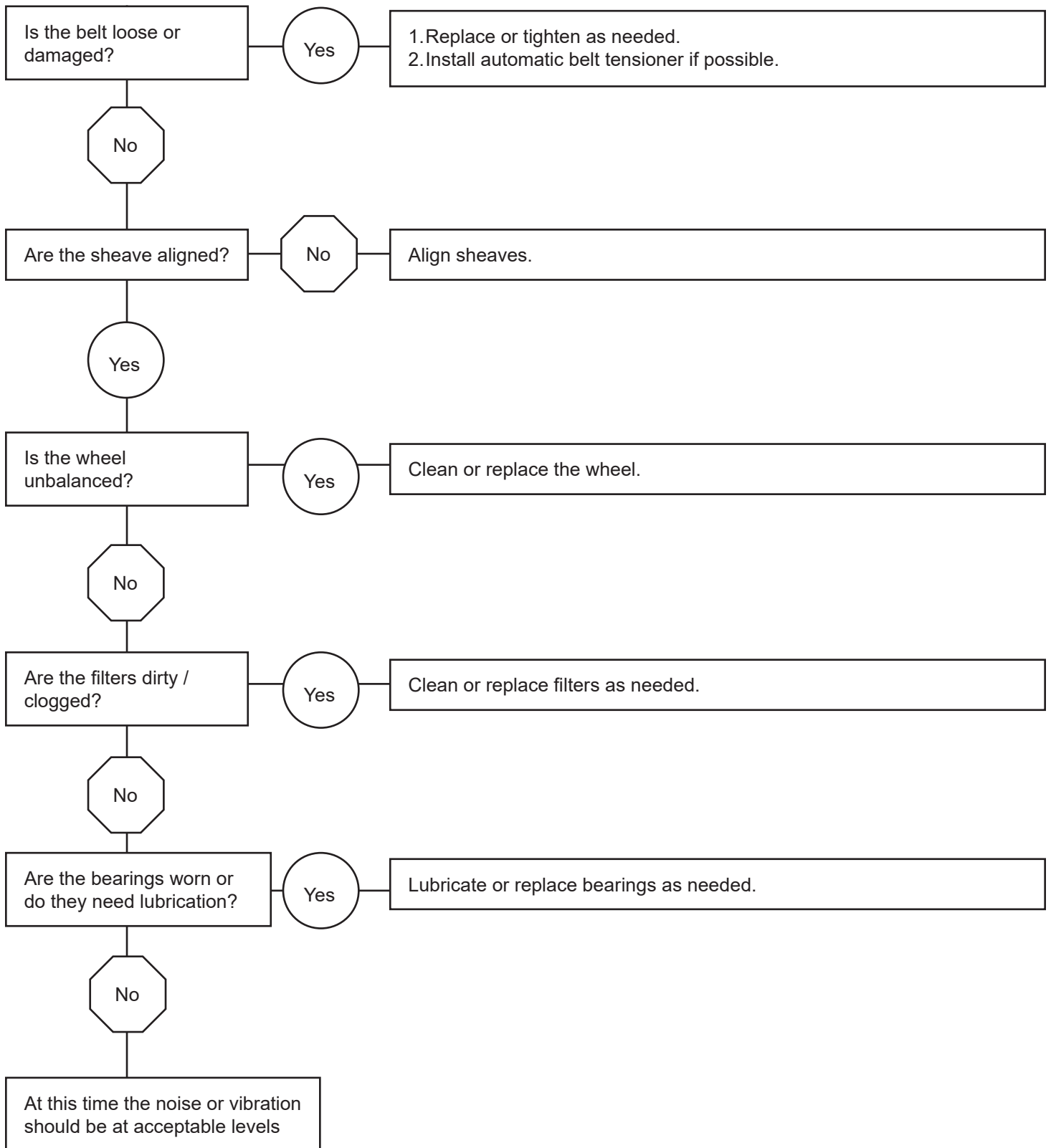

Refer to the control panel parts list when troubleshooting.

Troubleshooting

Heater does not attempt to light. Heater attempts to light, but no flame

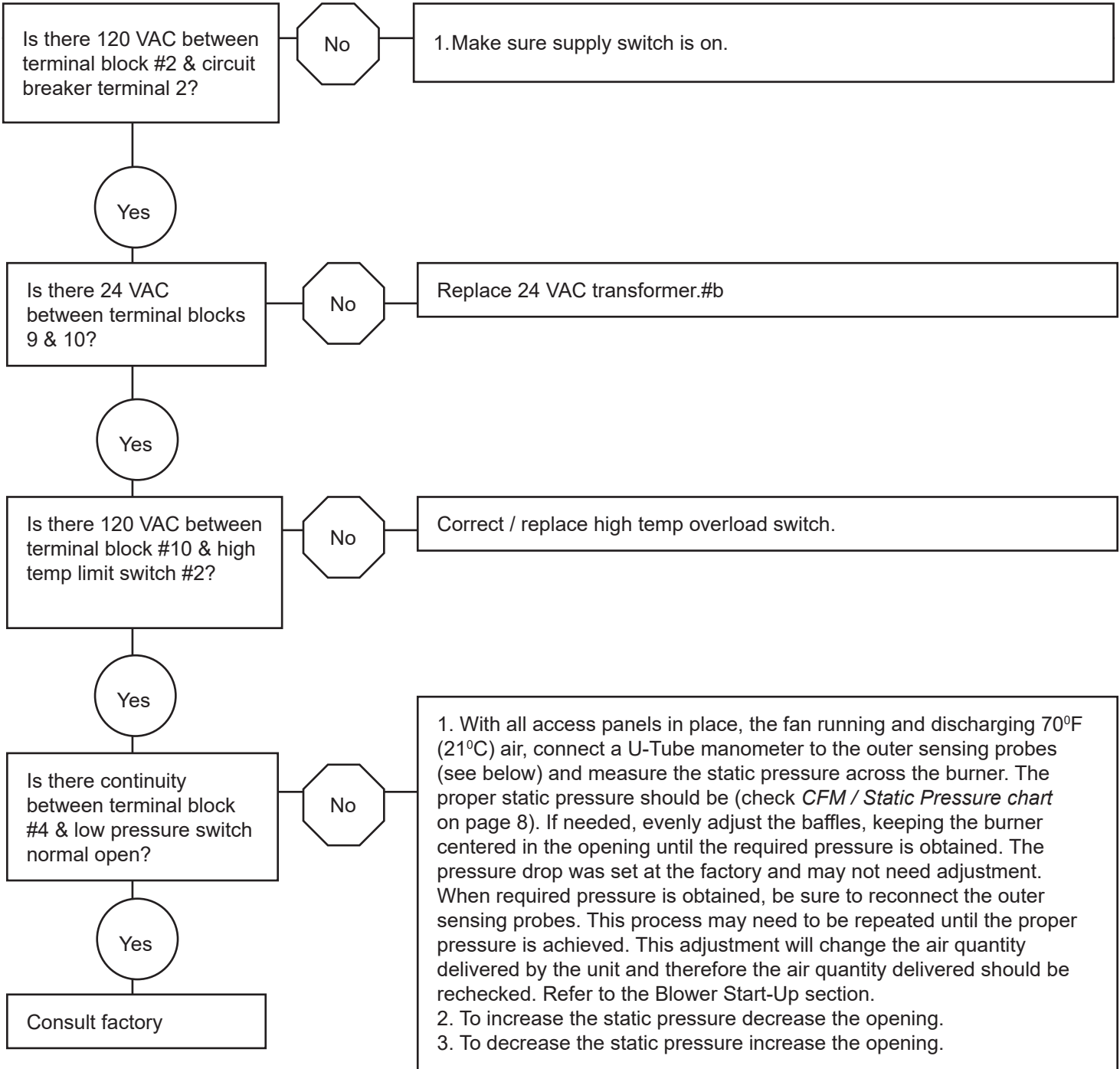

Refer to the control panel parts list when troubleshooting.

Troubleshooting

Attempts to light, with visible spark, but no flame

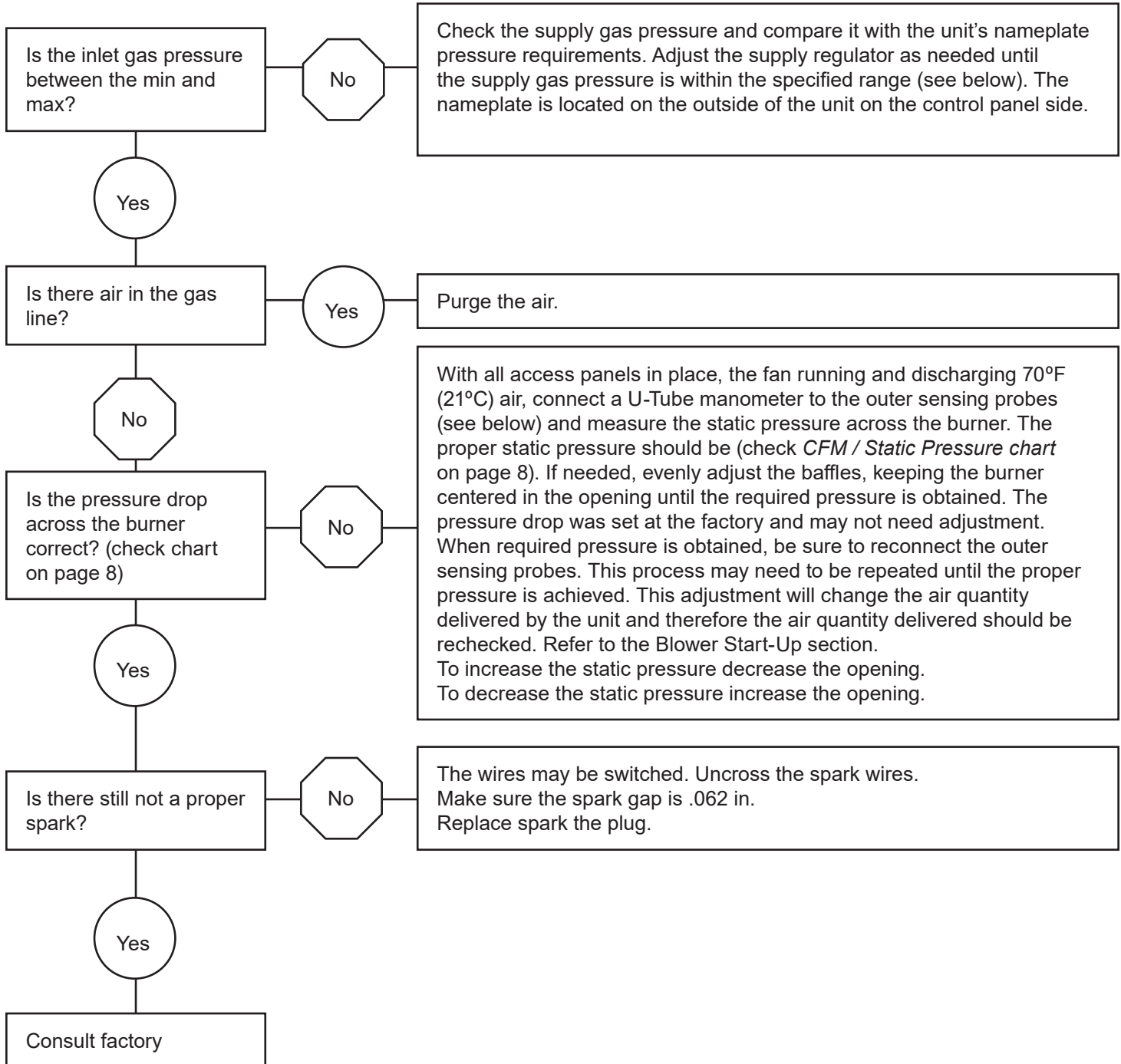

Refer to the control panel parts list when troubleshooting.

Service Contacts

Dealer: Name:
 Address:

 Phone:

**Installation
Contractor:** Name:
 Address:

 Phone:

**Service
Contractor:** Name:
 Address:

 Phone:

Date of Installation:

Limited Warranty

Loren Cook Company warrants that your Loren Cook fan was manufactured free of defects in materials and workmanship, to the extent stated herein. For a period of one (1) year after date of shipment, we will replace any parts found to be defective without charge, except for shipping costs which will be paid by you. This warranty is granted only to the original purchaser placing the fan in service. This warranty is void if the fan or any part thereof has been altered or modified from its original design or has been abused, misused, damaged or is in worn condition or if the fan has been used other than for the uses described in the company manual. This warranty does not cover defects resulting from normal wear and tear. To make a warranty claim, notify Loren Cook Company, General Offices, 2015 East Dale Street, Springfield, Missouri 65803-4637, explaining in writing, in detail, your complaint and referring to the specific model and serial numbers of your fan. Upon receipt by Loren Cook Company of your written complaint, you will be notified, within thirty (30) days of our receipt of your complaint, in writing, as to the manner in which your claim will be handled. If you are entitled to warranty relief, a warranty adjustment will be completed within sixty (60) business days of the receipt of your written complaint by Loren Cook Company. This warranty gives only the original purchaser placing the fan in service specifically the right. You may have other legal rights which vary from state to state. For fans provided with motors, the motor manufacturer warrants motors for a designated period stated in the manufacturer's warranty. Warranty periods vary from manufacturer to manufacturer. Should motors furnished by Loren Cook Company prove defective during the designated period, they should be returned to the nearest authorized motor service station. Loren Cook Company will not be responsible for any removal or installation costs.



LOREN COOK COMPANY

Corporate Offices: 2015 E. Dale St. Springfield, MO 65803
Phone 417-869-6474 | Fax 417-862-3820 | lorencook.com