



COOK

ADB

DATE: _____

PROJECT: _____

LOCATION: _____



**Tube Axial Drum Fan
Cast Aluminum Propeller
Belt Drive**

DIMENSION DATA

Size	A	B	C	Drum Ga.	Ship Wt.
16	16	19-1/2	1-1/2	14 ga.	90
20	20	23-1/2	1-1/2	14 ga.	110
24	21	27-1/2	1-1/2	12 ga.	147
30	25	33-1/2	1-1/2	12 ga.	224
36	30	39-1/2	1-1/2	12 ga.	315
42	31	45-3/4	1-5/8	10 ga.	390
48	33	52-3/4	2-1/8	10 ga.	470

ALL DIMENSIONS IN INCHES. WEIGHTS IN LBS.

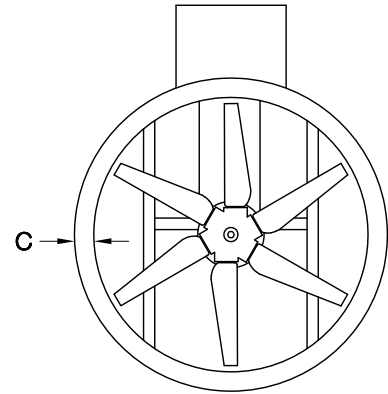
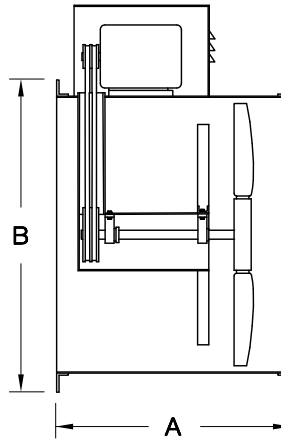

STANDARD CONSTRUCTION FEATURES:

Cast aluminum propeller – Extended lube lines on bearings –
Adjustable pitch drives through 5 HP motor – Painted steel housing –
Permanently lubricated ball bearing motors – Static resistant belts –
Corrosion resistant fasteners – American made bearings rated at
200,000 hours average life – All fans factory adjusted to specified
fan RPM.

ACCESSORIES

1. DISCONNECT SWITCH
2. INLET/OUTLET GUARD
3. FLOOR MOUNTING FEET
4. HANGING BRACKETS (V OR H)
5. INLET BELL
6. WEATHER COVER
7. BELT GUARD
8. SPECIAL

QTY	MARK	CATALOG NUMBER	FAN INFORMATION			MOTOR INFORMATION					ACCESSORIES							
			CFM	SP	RPM	HP	VOLTS	HZ	PH	TYPE								

LARGEST MOTOR SHIPPED MOUNTED: ODP (OPEN DRIP-PROOF) 5 HP; 2 SP (2 SPEED) 2 HP;
X-PRF (EXPLOSION PROOF) 2 HP; TEFC (TOTALLY ENCLOSED FAN COOLED) 3 HP.

WP072R02