



COOK

AVAB

DATE: _____

PROJECT: _____

LOCATION: _____



Adjustable Pitch Vane Axial Horizontal Floor Mount Belt Drive Arrangement 9

DIMENSION DATA

Size	A	B	C	D	E	F	G	H	J	K	L
35	35-1/2	39-7/8	38	3/16	43	9/16	12	35-1/8	39-3/4	1-5/8	23
39	39-3/8	43-15/16	41-7/8	1/4	43	9/16	12	37-1/8	39-1/2	1-3/4	26
44	44-1/8	49-5/8	47-3/8	1/4	47	9/16	12	42-5/8	43-1/2	1-3/4	28-1/2
49	49-1/4	54-3/4	52-1/2	1/4	47	9/16	12	43-9/16	43-1/2	1-3/4	31-1/2
57	57-1/8	62-5/8	59-7/8	1/4	61	9/16	12	44-5/8	57-1/2	1-3/4	33
63	63	68-1/2	66-1/4	1/4	61	11/16	16	46-3/4	57-1/2	1-3/4	40
71	70-7/8	77-5/8	75	3/8	72	11/16	16	64-1/4	67-1/2	2-1/4	44
79	78-3/4	85-9/16	82-7/8	3/8	72	11/16	16	67-1/4	67-1/2	2-1/4	47-1/2

Size	M	N	P	ODP Max. Mtr. Frame	Ship Wt. less Mtr.
35	41	12	5/8	326T	715
39	45	13-3/8	5/8	365T	953
44	51	15-3/8	5/8	445T	1144
49	56	17	5/8	445T	1549
57	68	21	5/8	445T	2021
63	70	21-5/8	3/4	445T	2298
71	78-1/2	24-3/8	3/4	445T	3740
79	87	27-3/8	3/4	445T	4144

ALL DIMENSIONS IN INCHES. WEIGHTS IN LBS.

STANDARD CONSTRUCTION FEATURES:

All aluminum adjustable pitch prop -
 Minimum 3/16" Lorenized steel housing
 with integral straightening vanes -
 Extended lube lines - Regreasable
 bearings in cast pillow block housing -
 Rotatable bolted mounting feet.

ACCESSORIES

1. INLET/OUTLET GUARD
2. INLET/OUTLET COMPANION FLANGE
3. VIBRATION ISOLATORS
4. INLET BELL
5. INLET/OUTLET CONE
6. INSPECTION DOOR
7. SOUND MUFFLER
8. MOTOR COVER
9. BELT GUARD
10. BOMBAY DOORS

NOTE: Feet can be rotated for
ceiling suspension.

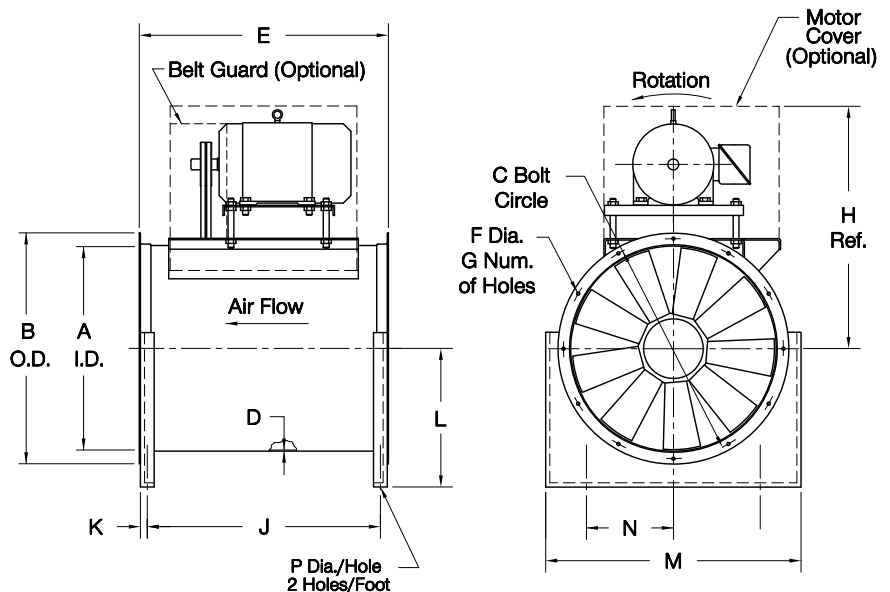

LARGEST MOTOR SHIPPED MOUNTED: ODP (OPEN DRIP-PROOF) 25 HP; 2 SP (2 SPEED) 20 HP;
 X-PRF (EXPLOSION PROOF) 20 HP; TEFC (TOTALLY ENCLOSED FAN COOLED) 20 HP.

VA100R02