

DATE: \_\_\_\_\_

PROJECT: \_\_\_\_\_

LOCATION: \_\_\_\_\_

Accessory Data Sheet  
**Bypass Damper**  
 Low Leakage Class 1A Rated  
 for CAVP Mixing Box

**STANDARD CONSTRUCTION FEATURES:**

- Frame: 5" x 1" x 6063T5 extruded hat channel with .125" minimum wall thickness
- Blades: 6" wide, 6063T5 heavy gauge extruded aluminum, airfoil shape. Opposed blade standard.
- Seals: Synthetic polymer blade edge seals and flexible SS compressible jamb seals.
- Bearings: Molded synthetic.
- Linkage: Concealed in frame.
- Axles: 1/2" plated steel hex.
- Temperature Limits: -72°F and +275°F.
- Damper provided with manual hand quadrant.
- Finish: Air-dry enamel coating to match fan color.

**OPTIONAL CONSTRUCTION FEATURES:**

- Air-dry epoxy finish.
- Actuator out of Airstream, 1 Actuator per panel, protected from weather. Available in 24vdc or 24vac. See table below for optional actuator model. Power Open/Spring Close (Reversible).
- Pneumatic actuator.

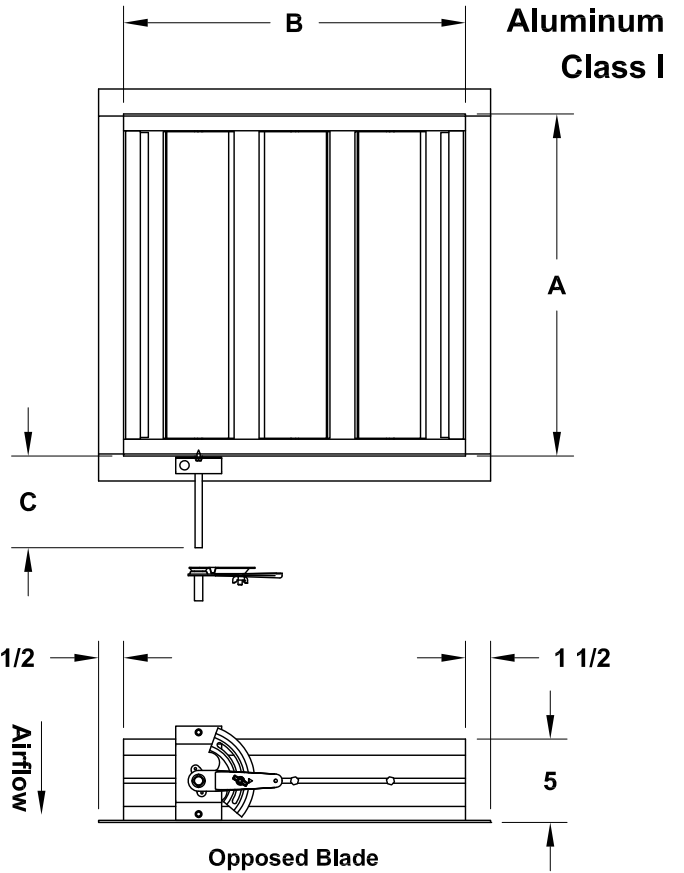
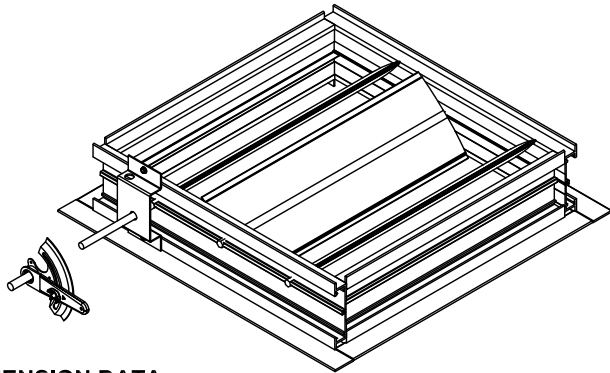

**DIMENSION DATA**

Qty	Mark	Size	A	B	C	No. Panels	Actuator Model	No. Actuators	Unit Weight	
									Quadrant	Actuator
		120	9-1/2	7-1/2	5	1	LF24-SR-S	1	4	7
		135	11	8-1/2	5	1	LF24-SR-S	1	4	7
		150	12-1/2	10	5	1	LF24-SR-S	1	5	8
		165	14-1/2	10-3/4	5	1	LF24-SR-S	1	6	9
		180	16	12-1/4	5	1	LF24-SR-S	1	8	11
		195	17-1/2	13-1/2	5	1	LF24-SR-S	1	9	12
		210	19-1/4	14-1/2	6	1	LF24-SR-S	1	11	14
		225	20-3/4	16	6	1	LF24-SR-S	1	13	16
		245	22-3/4	17-3/4	6	1	LF24-SR-S	1	15	18
		270	25-1/4	20-3/4	6	1	LF24-SR-S	1	19	22
		300	28-1/4	23-3/4	6	1	LF24-SR-S	1	25	28
		330	31-1/4	26-1/2	6	1	LF24-SR-S	1	30	33
		365	34-3/4	30-1/2	7	1	NFB24-SR-S	1	38	44
		402	38-1/2	34-1/4	8	1	NFB24-SR-S	1	47	53
		445	42-3/4	39-1/4	12	1	NFB24-SR-S	2	60	73
		490	48-1/2	35-3/4	14	2	NFB24-SR-S	2	62	75
		540	53-1/2	40-1/4	17	2	AFB24-SR-S	2	77	89
		600	59-1/2	46	17	2	AFB24-SR-S	2	98	110
		660	65-1/2	51-3/4	17	2	AFB24-SR-S	2	121	133
		730	72-1/2	58-3/4	17	2	AFB24-SR-S	2	151	163

ALL DIMENSIONS IN INCHES. WEIGHTS IN LBS. WEIGHT INCLUDES HAND QUADRANT OR ACTUATOR.

X0243R00