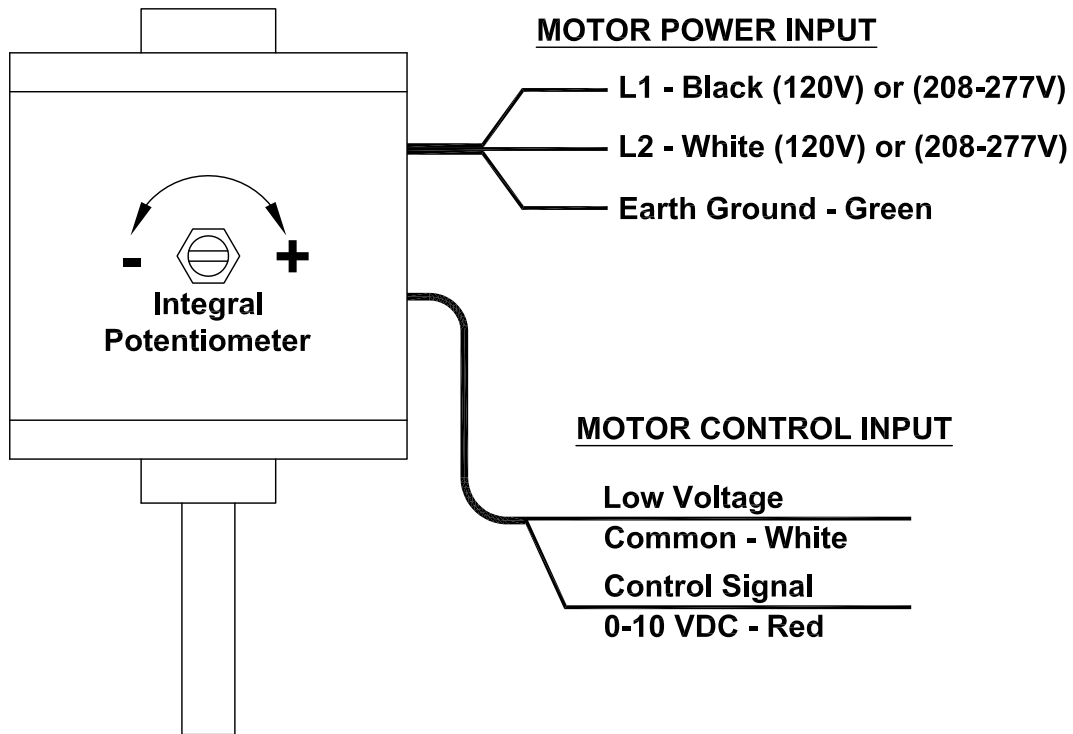

MARK: _____

PROJECT: _____

DATE: _____

Accessory Data Sheet
External Speed Control
Electronically Commutated (EC) Motor
Type M1

**STANDARD CONSTRUCTION FEATURES:**

External signal speed control requires a 0-10 VDC control signal to adjust speed of the motor - The motor will operate from 2-10 VDC and turns off when the control signal is below 1.9 VDC. Integral potentiometer must be set to full speed when using external speed control.