



COOK

BDMIC-VC

DATE: _____

PROJECT: _____

LOCATION: _____

**Backdraft Motorized Intake
Center Pivot Damper
ERV Return Air Arrangement V & C**

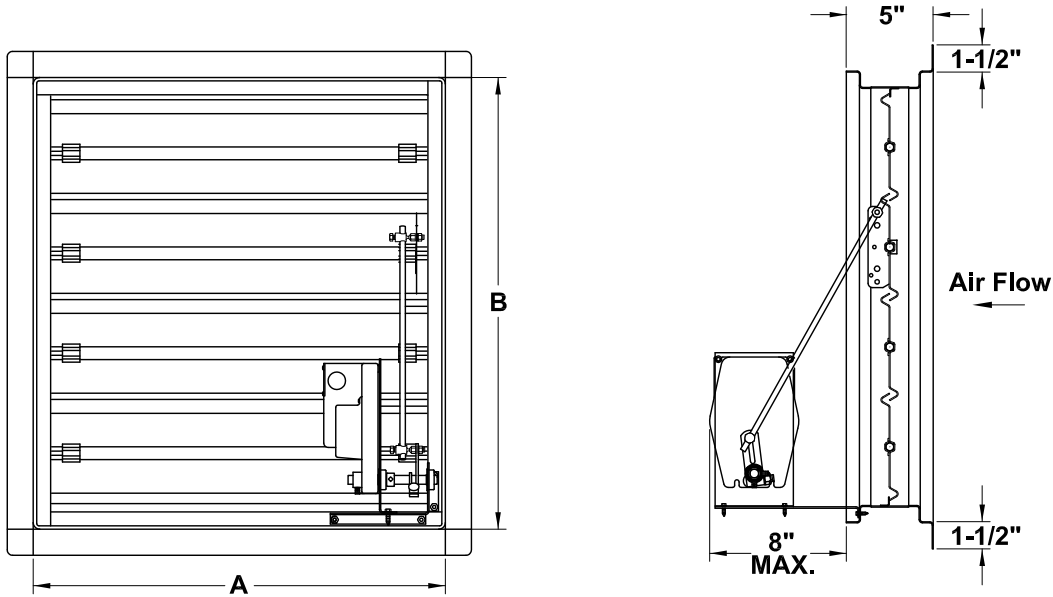

STANDARD CONSTRUCTION FEATURES:

16 ga galvanized steel blades - 16 ga galvanized steel frame -
1/2" plated steel hex hinge pins - Molded synthetic bearings -
24VAC Non-overloading motor.

DIMENSION DATA

Qty	Mark	Unit Size	Cat. No.	A	B	Unit Wt.
		1500	BDMIC-VC-1500	18-3/4	12-3/4	19
		2500	BDMIC-VC-2500	21-3/4	12-1/2	21
		3500	BDMIC-VC-3500	22-3/4	16-1/4	25
		4500-5500	BDMIC-VC-4500	25-3/4	18-1/2	31
		7000-8500	BDMIC-VC-7000	31-3/4	23-3/4	44
		10000	BDMIC-VC-10000	34-1/4	32-3/4	62

ALL DIMENSIONS IN INCHES. WEIGHTS IN LBS.