

MARK: _____
 PROJECT: _____
 DATE: _____

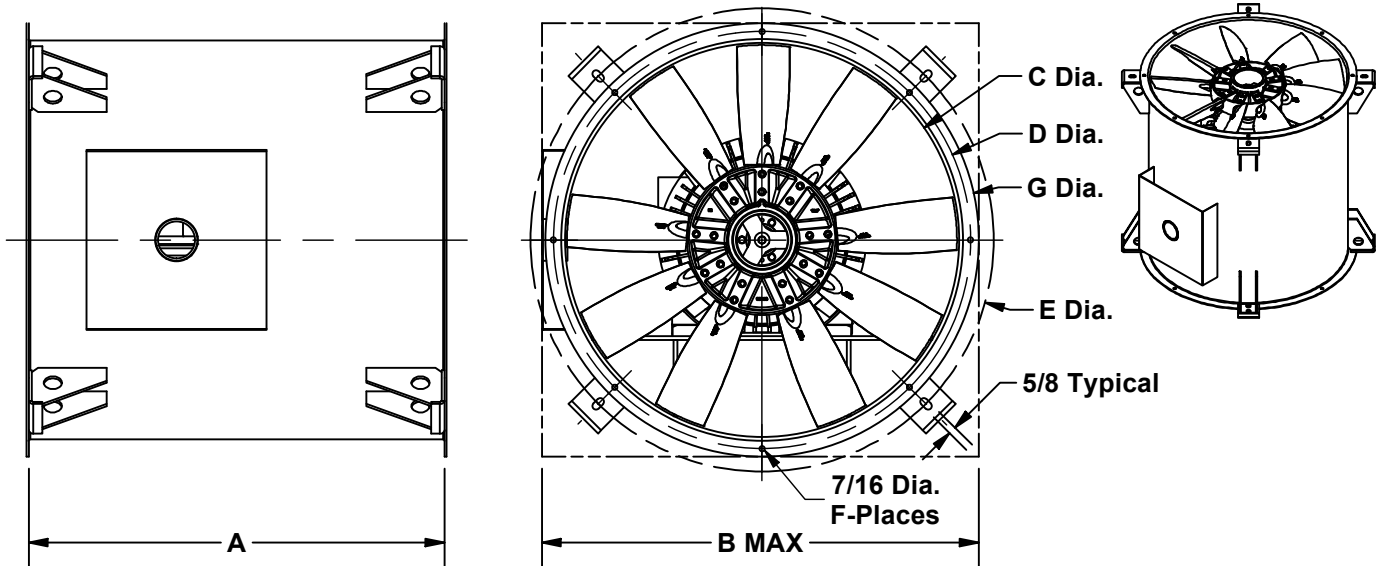

**Axial Inline Fan
 Vertical Mount
 Direct Drive
 Arrangement 4, Level II**



STANDARD CONSTRUCTION FEATURES:

High efficiency, heavy duty cast aluminum impeller - Continuously welded steel housing with Lorenized powder coating - Integral pre-punched inlet and outlet flanges - Corrosion resistant fasteners - Lifting Lugs - Rigid motor support welded to housing - Totally enclosed motor - Motor leads extended to exterior of the housing to a NEMA 1 wiring compartment

DIMENSION DATA

Size	A	B	C	D	E	F	G	Max Motor Frame	Unit Wt.
41	25	20 1/2	16 1/2	18 1/8	22	8	19 1/4	215T	99
47	25	22 1/16	18 5/8	20 1/4	24 3/16	8	21 3/4	215T	115
54	30	24 7/8	21 5/8	23 5/16	27 1/4	8	24 3/4	256T	169
63	30	28	24 5/8	26 5/16	30 1/4	8	27 7/8	256T	206
72	33	32 5/16	28 7/8	30 9/16	34 9/16	8	32 1/8	286T	258
80	35	36 3/8	32 7/8	34 3/4	38 5/8	8	36 1/8	326T	382
90	39	41 5/16	37	39 1/4	42 15/16	8	41 1/4	365T	596
103	39	45 5/8	41 1/8	43 3/8	47 1/16	8	45 3/8	365T	695
113	45	49 7/8	45 1/4	47 1/2	51 3/16	8	49 1/2	405T	998
123	50	54 3/16	49 3/8	51 5/8	55 5/16	16	53 3/4	445T	1180
140	50	61	56	58 1/4	61 15/16	16	60 1/2	445T	1409
160	50	69 1/4	64 1/8	66 3/8	70	16	68 5/8	445T	1634

ALL DIMENSIONS IN INCHES. WEIGHTS IN LBS., LESS MOTOR.