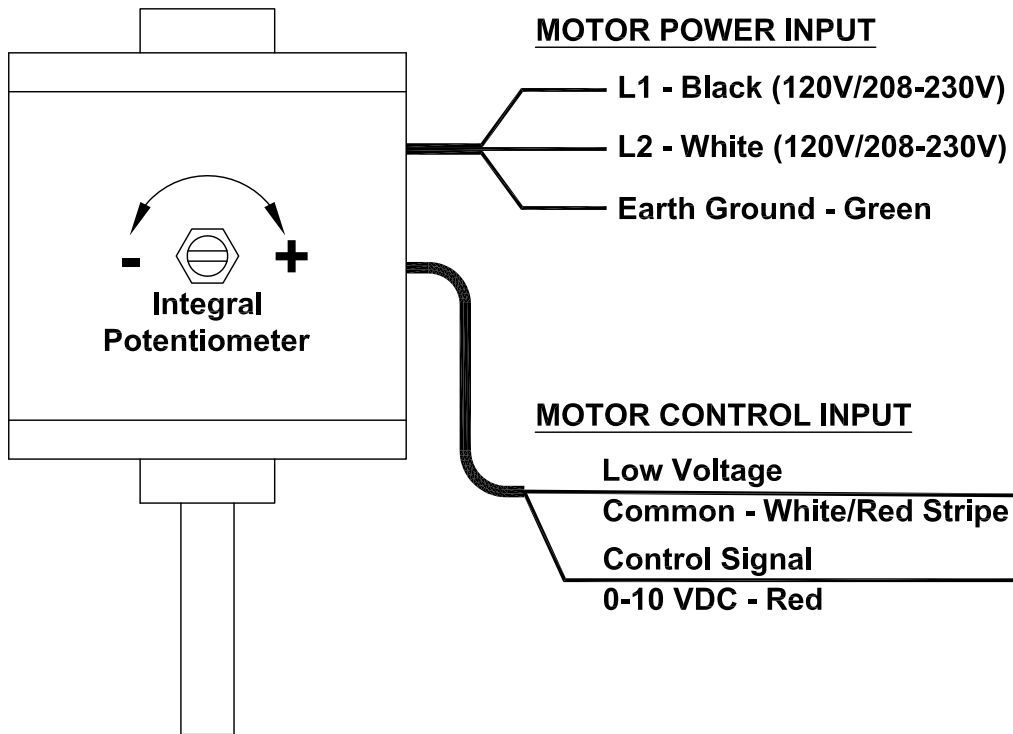

MARK: _____

PROJECT: _____

DATE: _____

Accessory Data Sheet
External Speed Control
Electronically Commutated (EC) Motor
Type P

**STANDARD CONSTRUCTION FEATURES:**

Integral potentiometer with slotted screw for speed adjustment.