

Economizer Fan



Economizer Fan

Hooded Propeller Fans with Mix, Recirculate, Supply and Exhaust Modes



Introduction & Construction Features	2
Operation Modes	2
Specification and Dimension Data	
MRS-D	3
MRSE-D	4
Accessories	5

Introduction & Construction Features

Building ventilation requirements are often dictated by changes in the outside air temperature, production processes within a facility and / or occupancy within a facility. Loren Cook Company's Economizer Fan offers the flexibility to maintain comfortable temperatures in factories, gymnasiums, equipment rooms, warehouses, manufacturing plants or other facilities with a high internal heat load. The mixing of cool outside air with warm inside air, "free cooling," provides a more comfortable air temperature to any facility. It is the fan's most economical function. The Economizer Fan can also recirculate inside air, supply cool outside air to a facility, or exhaust warm or contaminated air.



MRS-D MRSE-D

- Steel curb cap with continuously welded corners and Lorenized™ fan finish.
- 14 gauge galvanized steel plenum with two access doors.
- Heavy duty galvanized steel control dampers.
- Galvanized steel hood.
- Bird screen.
- Corrosion resistant fasteners.
- Heavy duty steel power assembly with extruded aluminum propeller.

Operation Modes

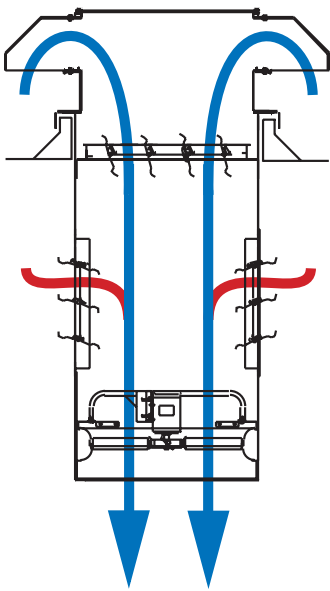

Mix
Cool outside air is mixed with warm inside air to provide more comfortable building temperatures.

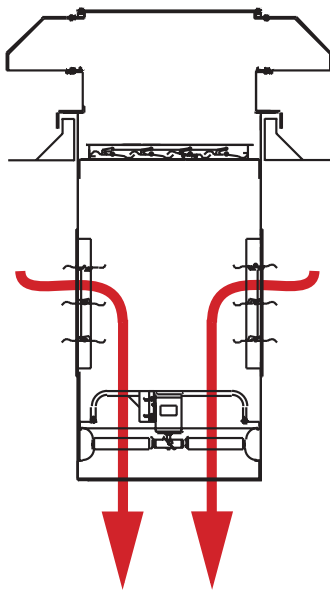

Recirculation
Warm inside air at roof level is forced downward to reduce heating costs.

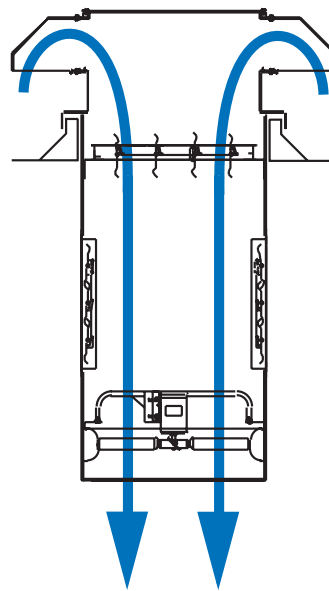

Supply
Cool outside air is supplied into the building to reduce cooling costs.

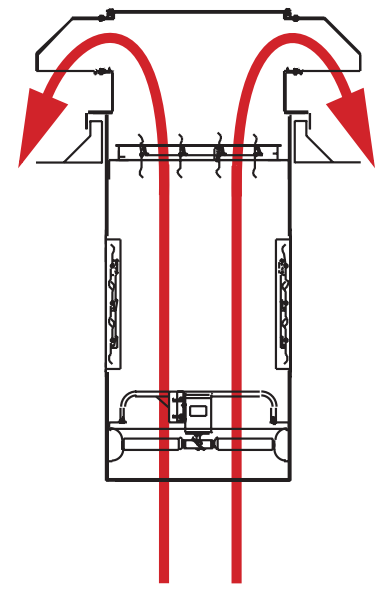

Exhaust
Warm or contaminated inside air is exhausted from the building.

Typical Specifications and Dimensions

MRS-D: Mix-Recirculate-Supply Prop. Roof Fan



- Description - Fan shall be hooded, roof mounted, direct driven, propeller economizer fan.
- Operation Modes - Mix outside air with recirculated air, recirculate inside air, supply outside air.
- Certification - Fan shall be manufactured at an ISO 9001 certified facility. Fan shall be listed by Underwriters Laboratories (UL 705) and UL listed for Canada (cUL 705).
- Construction - The fan shall be of bolted and welded construction utilizing corrosion resistant fasteners. The hood shall be constructed of 18 gauge galvanized steel. The hood base shall be minimum 14 gauge Lorenized steel with continuously welded curb cap corners. The plenum shall be constructed of 14 gauge galvanized steel and provided with integral lifting lugs, propeller safety screen and two access doors. Outside air damper and recirculated air dampers shall be constructed of galvanized steel frame and blades. The motor shall be mounted to a minimum 14 gauge tubular steel power assembly. The propeller shall be located in a double venturi for efficient air flow in all modes of operation. Unit shall bear an engraved aluminum nameplate. Unit shall be shipped in ISTA certified transit tested packaging.
- Propeller - Propeller shall be extruded aluminum airfoil design with cast aluminum hub. The blade pitch shall be factory set and locked using set screws and roll pin. The hub shall be keyed and locked to the shaft utilizing two set screws or a taper lock bushing. Propeller shall be balanced in accordance with AMCA Standard 204-05, Balance Quality and Vibration Levels for Fans.
- Motor - Motor shall be Nema design B with class B insulation rated for continuous duty and furnished at the specified voltage, phase and enclosure.
- Product - Fan shall be model MRSE-D as manufactured by Loren Cook Company of Springfield, Missouri.



Type Economizer Fan is furnished standard with UL 705 and CUL listing (Power Ventilator/ZACT) when furnished with factory supplied motor.

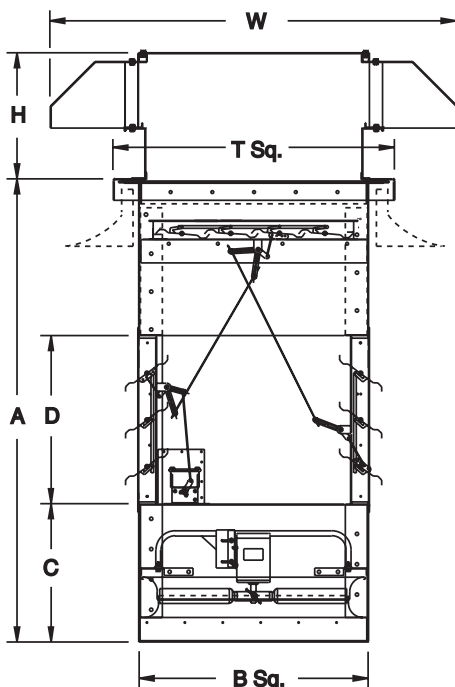

MRS-D Dimension Data

Size	A	B Sq.	C	D Sq.	H	W Sq.	T Sq.	Material Gauge			Roof Opening Square*	Approx. Ship Wt.-Lbs.
								Base	Hood	Plenum		
24	60-1/4	31-1/2	18	22-1/4	26	59	37-1/2	14	18	14	32-1/2	635
30	65-3/4	37-1/2	18	27-3/4	28	69	43-1/2	14	18	14	38-1/2	785
36	71-1/4	43-1/2	18	33-1/4	29	80	49-1/2	14	16	14	44-1/2	910
42	78-3/4	49-1/2	20	38-3/4	39	90	55-1/2	14	16	14	50-1/2	1125
48	84-1/4	55-1/2	20	44-1/4	39	90 x 110	61-1/2	14	16	14	56-1/2	1480
54**	89-3/4	61-1/2	20	49-3/4	42	109	67-1/2	14	18	14	62-1/2	1850

All dimensions in inches.

*Roof opening size for curbs supplied by Cook only.

**Sizes 54 require field assembly of hood.

Typical Specifications and Dimensions

MRSE-D: Mix-Recirculate-Supply-Exhaust Prop. Roof Fan



- Description - Fan shall be hooded, roof mounted, direct driven, propeller economizer fan.
- Operation Modes - Mix outside air with recirculated air, recirculate inside air, supply outside air, exhaust inside air.
- Certification - Fan shall be manufactured at an ISO 9001 certified facility. Fan shall be listed by Underwriters Laboratories (UL 705) and UL listed for Canada (cUL 705).
- Construction - The fan shall be of bolted and welded construction utilizing corrosion resistant fasteners. The hood shall be constructed of 18 gauge galvanized steel. The hood base shall be minimum 14 gauge Lorenized steel with continuously welded curb cap corners. The plenum shall be constructed of 14 gauge galvanized steel and provided with integral lifting lugs, propeller safety screen and two access doors. Outside air damper and recirculated air dampers shall be constructed of galvanized steel frame and blades. The motor shall be mounted to a minimum 14 gauge tubular steel power assembly. The propeller shall be located in a double venturi for efficient air flow in all modes of operation. Unit shall bear an engraved aluminum nameplate. Nameplate shall indicate design CFM and static pressure. Unit shall be shipped in ISTA certified transit tested packaging.
- Propeller - Propeller shall be a reversible, extruded aluminum airfoil design with cast aluminum hub. The blade pitch shall be factory set and locked using set screws and roll pin. The hub shall be keyed and locked to the shaft utilizing two set screws or a taper lock bushing. Propeller shall be balanced in accordance with AMCA Standard 204-05, Balance Quality and Vibration Levels for Fans.
- Motor - Motor shall be Nema design B with class B insulation rated for continuous duty and furnished at the specified voltage, phase and enclosure.
- Product - Fan shall be model MRSE-D as manufactured by Loren Cook Company of Springfield, Missouri.



Type Economizer Fan is furnished standard with UL 705 and CUL listing (Power Ventilator/ZACT) when furnished with factory supplied motor.

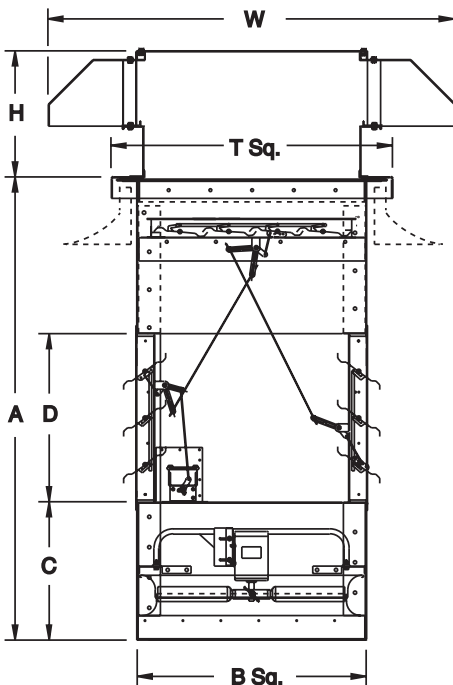

MRSE-D Dimension Data

Size	A	B Sq.	C	D Sq.	H	W Sq.	T Sq.	Material Gauge			Roof Opening Square*	Approx. Ship Wt.-Lbs.
								Base	Hood	Plenum		
24	60-1/4	31-1/2	18	22-1/4	26	59	37-1/2	14	18	14	32-1/2	635
30	65-3/4	37-1/2	18	27-3/4	28	69	43-1/2	14	18	14	38-1/2	785
36	71-1/4	43-1/2	18	33-1/4	29	80	49-1/2	14	16	14	44-1/2	910
42	78-3/4	49-1/2	20	38-3/4	39	90	55-1/2	14	16	14	50-1/2	1125
48	84-1/4	55-1/2	20	44-1/4	39	90 x 110	61-1/2	14	16	14	56-1/2	1480
54**	89-3/4	61-1/2	20	49-3/4	42	109	67-1/2	14	18	14	62-1/2	1850

All dimensions in inches.

*Roof opening size for curbs supplied by Cook only.

**Sizes 48 and 54 require field assembly of hood.

Accessories

Four-Way Outlet Diffuser



This diffuser is mounted to the bottom of the plenum to provide improved air distribution. The diffuser is constructed of 18 gauge steel and is coated with Cook's Lorenized™ fan finish.

Disconnect Switches

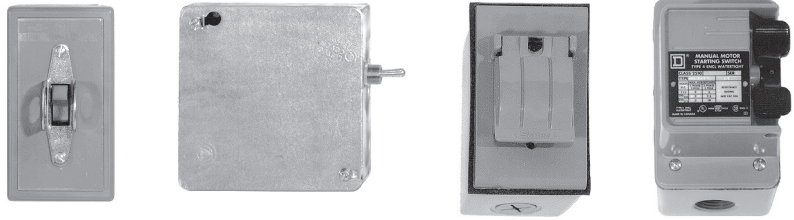

- NEMA 1 (Lockable) - Indoor, general purpose with lockable switch.
- NEMA 1 - Indoor, general purpose.
- NEMA 3R - Exterior mount, weather resistant.
- NEMA 4 - Water tight, dust tight.

Control Panel

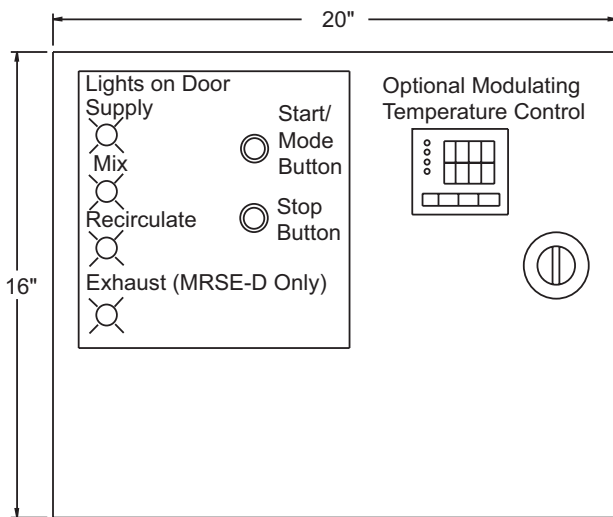

The optional remote mounted Economizer Control Panel allows fan operation and mode selection to be controlled from a convenient floor level location. All control components, including starters, are enclosed in a NEMA 1 cabinet with exterior start, stop and mode selection buttons. The model MRS control panel allows for selection of the mix, recirculate, and supply modes. The model MRSE panel allows for selection of the mix, recirculate, supply and exhaust modes.

Wiring Requirements - Each panel requires 110V (5A) input for controls operation and a fused motor input. The output of each panel includes the motor circuit and three-wire damper control. A temperature probe connection is required with the optional modulating temperature control package.

Optional Modulating Temperature Control Package - This optional package for the control panels above, allows the outlet temperature to be selected when in mix mode. In mix mode, the temperature controller allows an operator to set a target outlet temperature for the fan. The controller reads the fan outlet temperature from a field-mounted, three-wire RTD (included) and modulates the dampers to produce an outlet temperature equal to the target temperature.

Curb



- 18 gauge galvanized steel (RCG) or .080 aluminum (RCA).
- 1-1/2", 3 lbs. density thermal and acoustical insulation.
- Continuously welded corners.
- Wood nailer.
- Options
- No wood nailer (deduct 1-1/2" from height).
- 13-1/2" tall construction.

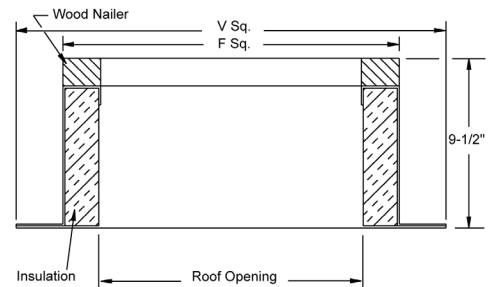

Additional Accessories

- Aluminum hood and roof base
- Insulated low leakage top damper
- Cabinet extensions - 12" and 24"
- Filters - Filtered Hoods 2" MERV 8

Pre-Fabricated Curb Dimension Data

Unit	RCG	F Sq.	V Sq.	Roof Opening	Approx. Ship Wt.-Lbs.
24	RCG-35	35-1/2	39-1/2	32-1/2	43
30	RCG-41	41-1/2	45-1/2	38-1/2	50
36	RCG-47	47-1/2	51-1/2	44-1/2	85
42	RCG-53	53-1/2	57-1/2	50-1/2	96
48	RCG-59	59-1/2	63-1/2	56-1/2	106
54	RCG-65	65-1/2	69-1/2	62-1/2	116

All dimensions in inches.



LOREN COOK COMPANY

2015 E. DALE STREET
SPRINGFIELD, MO 65803-4637

417.869.6474

FAX 417.862.3820

lorencook.com