

DATE: \_\_\_\_\_

PROJECT: \_\_\_\_\_

LOCATION: \_\_\_\_\_



Ceiling and Wall Blowers

900 Series

Vari-Flow®

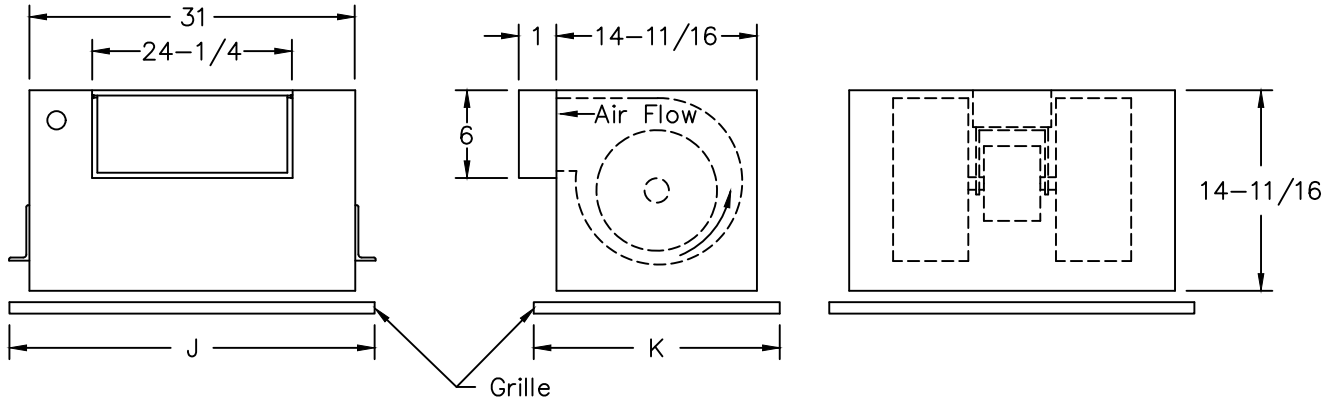

**DIMENSION DATA**

Series	Standard Grille		Deluxe AL Grille		Unit Wt.
	J	K	J	K	
900	35-1/8	17-1/8	32-3/4	16-1/4	86

ALL DIMENSIONS IN INCHES. WEIGHTS IN LBS.

**ACCESSORIES**

1. FAN SPEED CONTROL (2 Speed)
2. ROOF JACK
3. ROOF CAP
4. WALL CAP
5. EAVE ELBOW
6. FILTER
7. BRICK VENT
8. CEILING RADIATION DAMPER
9. HANGING VIBRATION ISOLATOR
10. TIME DELAY SWITCH
11. 277 VOLT TRANSFORMER
12. DELUXE ALUMINUM GRILLE
13. AIR BALANCE KIT
14. UNIVERSAL CONTROLLER
15. REMOTE SPEED CONTROLLER
16. PRESSURE CONTROLLER

**CATALOG NUMBER DEFINITION:**

GCVF - 900  
 Series: 900  
 TYPE: GC = Ceiling & Wall (includes Grille)  
 VF = VariFlow® (EC Motor)

**STANDARD CONSTRUCTION FEATURES:**

Forward curved galvanized steel fan wheels - Corrosion resistant  
 galvanized steel fan housing - Acoustically insulated housing -  
 Aluminum backdraft damper with solid aluminum hinge rod mounted in  
 brass bushings - Permanently lubricated electronically commutated variable speed  
 motor with built-in electronic overload protection and disconnect plug - Interchangeable  
 panels with removable fasteners allows the discharge to be easily changed -  
 Internal wiring box with disconnect receptacle - Powder painted white steel grille..

QTY	MARK	CATALOG NUMBER (see above)	FAN INFORMATION			MOTOR INFORMATION					ACCESSORIES								
			CFM	SP	RPM	HP	VOLTS	HZ	PH	TYPE									

MOTOR TYPE: EC (ELECTRONICALLY COMMUTATED)

GM032R00