



COOK

QMXVP/QMXHPVP

DATE: _____

PROJECT: _____

LOCATION: _____



Vari-Plume®

Laboratory Exhaust

Mixed-Flow Inline

Belt Drive

with Triple Mixing Box

Parallel Bypass

DIMENSION DATA

Size	A	B	C	D	E	F	G	H	J	K	L	M	Approx. Ship Wt.
90	92	28	27 3/16	23	38	34	10 9/16	8	19 3/4	99 1/2	100	36-1/2	2500
120	100	28	27 3/16	28	40 7/16	35	12 13/16	8	19 3/4	99 1/2	100	36-1/2	3340
135	108	28	27 1/8	28	41 5/8	36	14 13/16	8	18 9/16	99 1/2	100	36-9/16	3970
150	120	30	29 1/8	36	44 1/8	38	16 9/16	8	20 9/16	105 1/2	106	38-9/16	4370
165	125	32	31 1/8	36	45 1/2	41	18 5/16	8	22 9/16	111 1/2	112	40-9/16	4990
180	133	34	33 1/8	43	48	44	19 1/16	8	24 9/16	133 1/2	134	50-9/16	5880
202	143	38	36 15/16	50	51 7/8	49	22 9/16	8	28 9/16	141 1/4	142	52-9/16	6120
225	154	42	40 15/16	50	58	54	22 9/16	9	30 9/16	143 1/4	144	51-9/16	7750
245	165	44	42 15/16	61	60 5/8	57	24 13/16	9	32 9/16	171 5/16	172	64-9/16	8770
270	175	48	46 15/16	61	64 5/8	62	26 9/16	9	36 9/16	175 5/16	176	64-9/16	9980
300	197	52	50 15/16	74	69 7/16	68	29 13/16	9	40 9/16	211 5/16	212	80-9/16	12210
330	206	56	54 13/16	74	75 15/16	73	33 1/16	9	44 9/16	215 5/16	216	80-9/16	15180
365	233	62	60 3/4	89	81 5/8	82	35 1/16	11	46 7/16	255 1/4	257	97-3/4	19050
402	247	67	65 5/8	89	89 5/16	90	41 5/16	11	50 3/8	260 3/8	262	97-3/4	21170
445	276	74	72 5/8	89	96 1/8	102	47 1/16	13	55 3/8	267 3/8	269	97-3/4	22850
490	305	80	78 1/2	101	104 1/16	113	57 5/16	13	59 3/16	303 1/2	305	112-7/8	35280
540	336	87	85 3/8	101	111 3/8	126	66 1/16	15	62 3/16	316 3/8	318	115-3/4	40050
600	376	96	94 3/8	101	120 5/16	144	81 9/16	15	69 3/16	329 3/8	331	117-3/4	46850

ALL DIMENSIONS IN INCHES. WEIGHTS IN LBS., LESS MOTOR.

* RECOMMENDED CURB OUTSIDE SQUARE DIMENSION.

** MIXING BOX INSIDE SQUARE DIMENSION.

*** DIMENSION IS FROM THE BOTTOM OF THE CURB CAP TO THE TOP OF THE CURB.

STANDARD CONSTRUCTION FEATURES:

High efficiency, non-overloading mixed-flow welded wheel - Minimum 14 gauge steel welded housing - Welded aerodynamic straightening vanes - Double concentric accelerator fiberglass reinforced plastic induction nozzle and windband - Phenolic epoxy powder with UV protection (Light Gray) - L10/40k Concentric locking regreasable bearings - Bolted access door - Lifting lugs - Fan drain - Weather cover - Reinforced curb cap - Inlet duct collar - Stainless Steel shaft Stainless Steel hardware - Stainless Steel extended lube lines - NEMA 3R disconnect mounted and pre-wired - 1.5 Service factor drives - Designed to withstand 125 mph wind****

BYPASS PLENUM: Single wall welded steel construction with inner angle frame - Bottom inlet location - Phenolic epoxy powder with UV protection (Light Gray) - Plenum drain - Bolted access door - Painted aluminum bypass damper with manual hand quadrant - Painted aluminum isolation damper with 2 position actuator - Weather hood - Stainless steel birdscreen - Stainless Steel hardware - Designed to withstand 125 mph****

OPTIONAL FEATURES SHOWN:

Heavy Duty Lab Exhaust Curb
Side Intake Opening

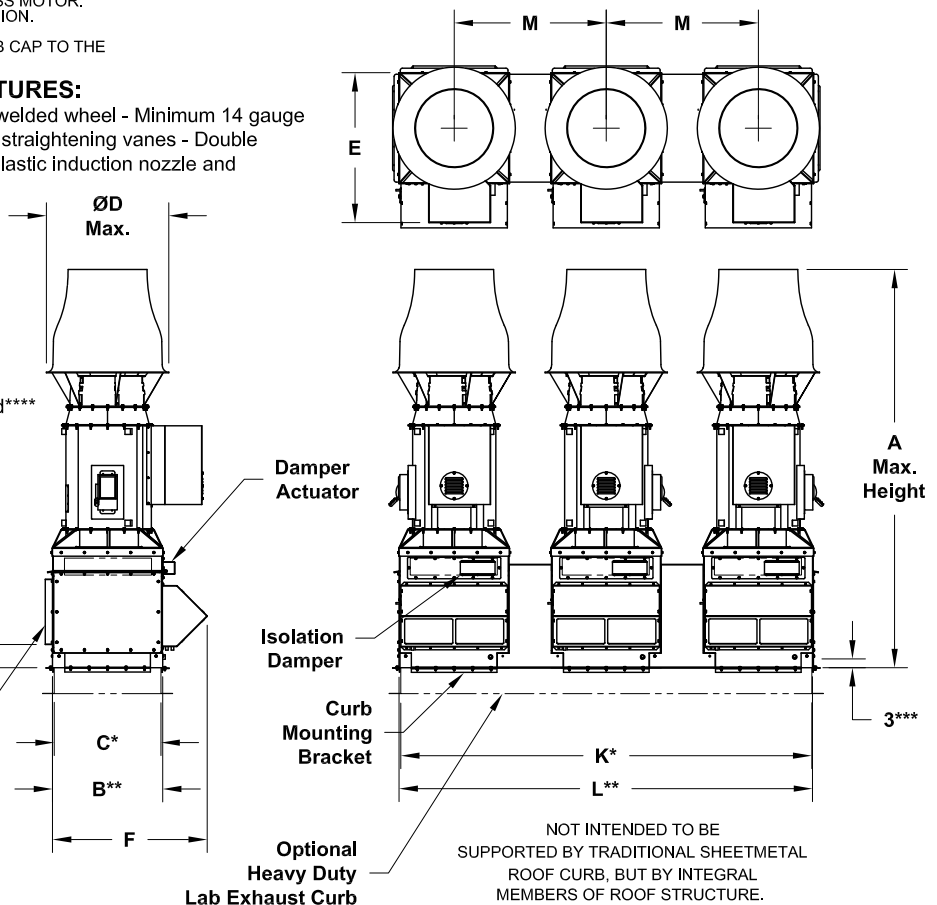

NOT INTENDED TO BE SUPPORTED BY TRADITIONAL SHEETMETAL ROOF CURB, BUT BY INTEGRAL MEMBERS OF ROOF STRUCTURE.

**** WINDLOAD RATING DEPENDANT ON ADEQUATE ATTACHMENT TO ROOF STRUCTURE.

TM019R01