

TCN

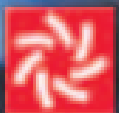

COOK

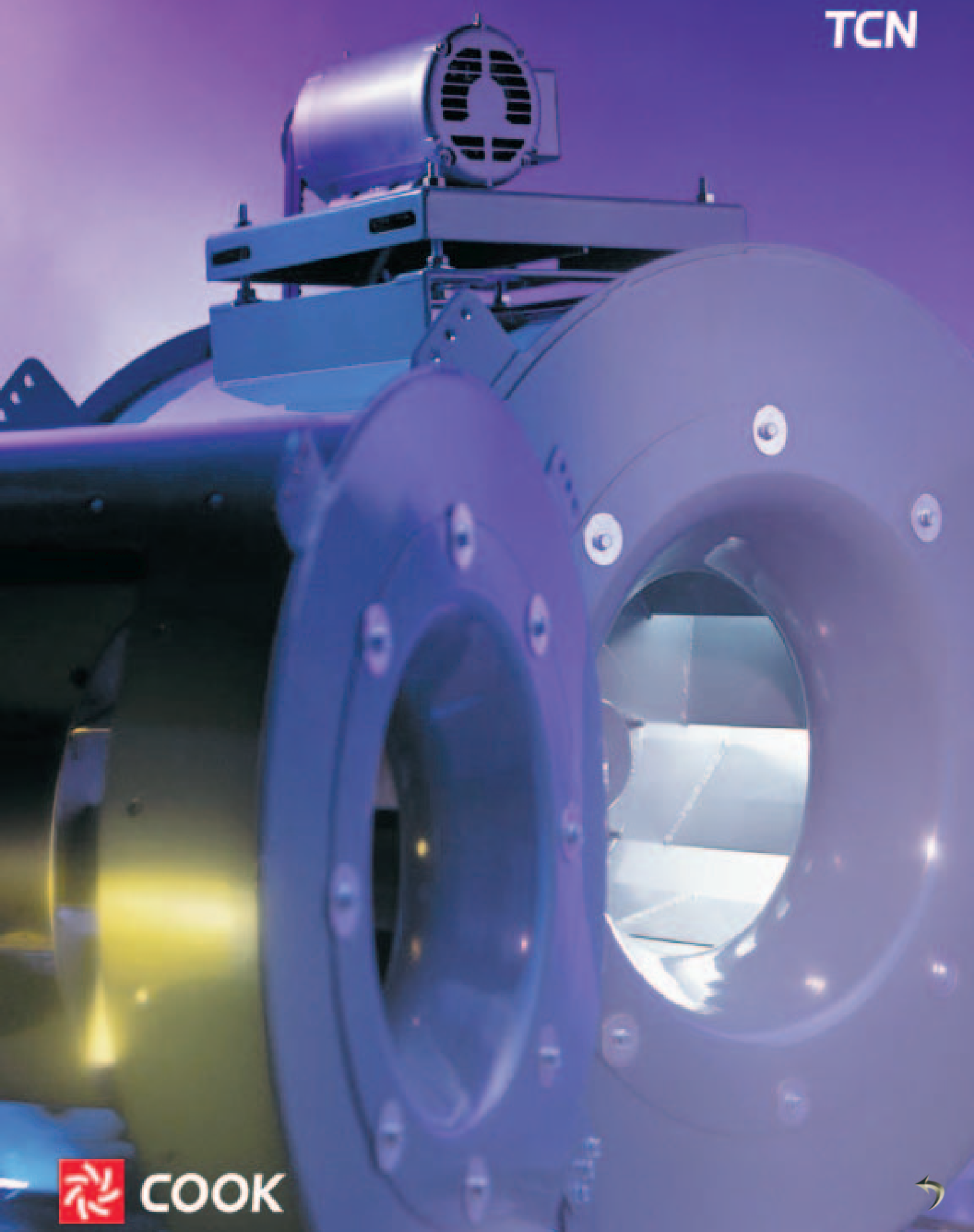

# TCN

Tubular Centrifugal Inline Fans

Page

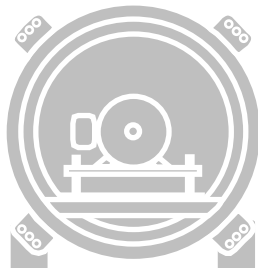
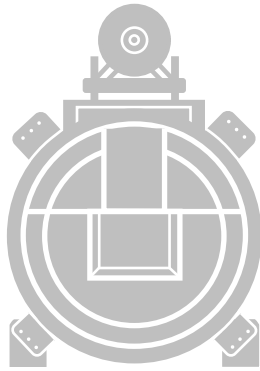

Introduction	2
Construction Features	3
<b>Specification and Dimension Data</b>	
TCN-D (Inline Fan- Direct Drive)	4
TCN-B (Inline Fan - Belt Drive)	5
TCNH-D (Inline Heavy Duty Fan - Direct Drive)	6
TCNH-B (Inline Heavy Duty Fan - Belt Drive)	7
Construction Information	8
Installation / Mounting	9
<b>Accessories</b>	
Accessories	10-12
<b>Performance Data</b>	
60-165 TCN-D and TCNH-D	13
60 TCN-B / TCNH-B	14
70 TCN-B / TCNH-B	15
80 TCN-B / TCNH-B	16
100 TCN-B / TCNH-B	17
120 TCN-B / TCNH-B	18
135 TCN-B / TCNH-B	19
150 TCN-B / TCNH-B	20
165 TCN-B / TCNH-B	21
180 TCN-B / TCNH-B	22
195 TCN-B / TCNH-B	23
210 TCN-B / TCNH-B	24
225 TCN-B / TCNH-B	25
245 TCN-B / TCNH-B	26
270 TCN-B / TCNH-B	27
300 TCN-B / TCNH-B	28
330 TCN-B / TCNH-B	29
365 TCN-B / TCNH-B	30
402 TCN-B / TCNH-B	31
445 TCN-B / TCNH-B	32
490 TCN-B / TCNH-B	33
<b>Sound Data</b>	
TCN-D / TCNH-D	34-37
TCN-B / TCNH-B	38-47
Other Available Products	48

# Introduction

Loren Cook Company's Tubular Centrifugal Inline fans are available in direct drive sizes from 60 to 165, and belt drive sizes from 60 to 490 in both standard and heavy duty construction. TCN performance ranges from 50 CFM to 52,000 CFM and static pressures up to 5 inches. With a full range of mounting options and accessories, the TCN is an effective alternative for round duct installations requiring high flow rates at low to moderate static pressures.

## TCN-D



- All TCN units are licensed to bear the AMCA Certified Ratings Seal for Sound and Air Performance.
- UL/cUL 705 listing is standard on all TCN units.
- Integral inlet and outlet flanges are provided for easy duct connection.
- A large access door is standard on direct drive models. This large access door allows for removal of the motor and the wheel without removing the fan from the ductwork.
- An inspection door is standard on belt drive models. It is oriented 180° from the motor providing access to the fan for cleaning and inspection.
- On belt drive models, the optional large access door allows removal of the bearings, shaft, and wheel for cleaning and maintenance without removing the fan from the ductwork.
- Bearings and drives are isolated from the airstream. Removable bearing and drive covers provide easy access for inspection and service.
- Extended lubrication lines are standard on belt drive units for ease in bearing maintenance.

## TCN-B



## Direct Drive (TCN-D shown)

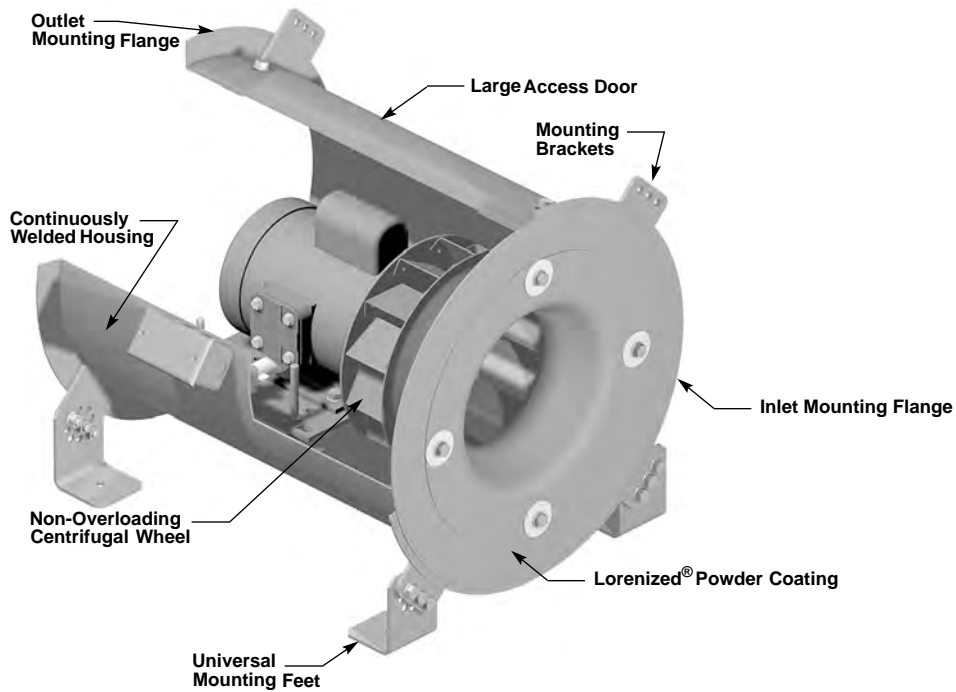

## Belt Drive (TCN-B shown)

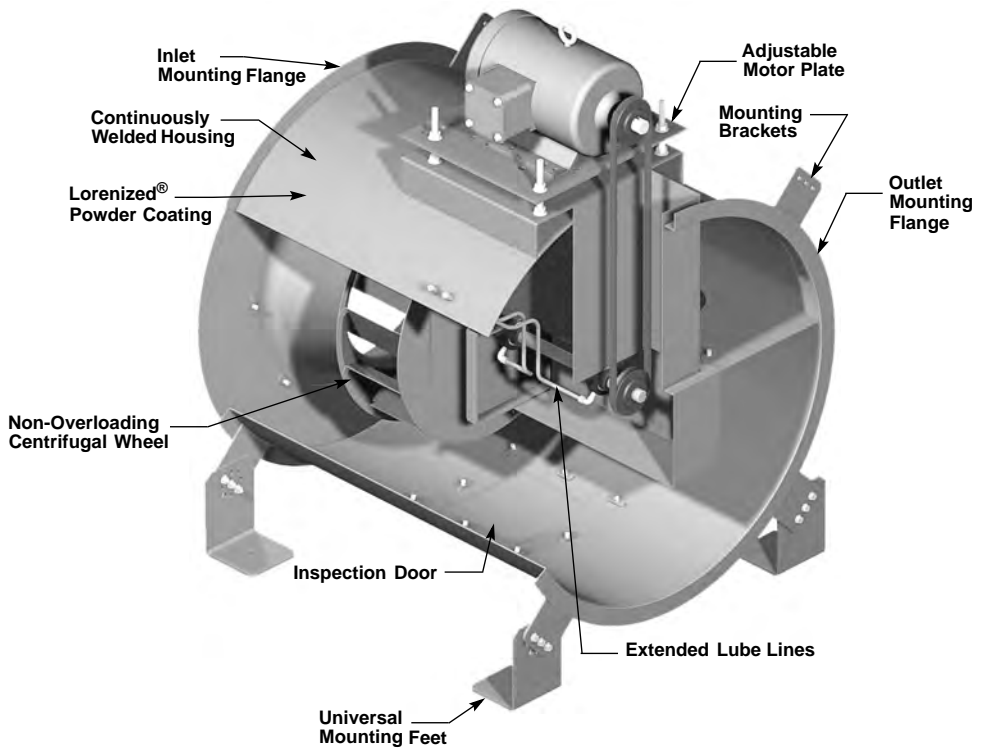

# TCN-D Specifications and Dimension Data

## Tubular Centrifugal Inline Fan Direct Drive



Loren Cook Company certifies that the TCN-D shown herein is licensed to bear the AMCA Seal. The ratings shown are based on tests and procedures performed in accordance with AMCA Publication 211 and AMCA Publication 311 and comply with the requirements of the AMCA Certified Ratings Program.



Type TCN-D is furnished standard with UL 705 and cUL 705 listings (Power Ventilator/ZACT).

**Description** - Fan shall be duct mounted, direct drive tubular centrifugal inline.

**Certifications** - Fan shall be listed by Underwriters Laboratories (UL 705 and UL listed for Canada, cUL 705). Fan shall bear the AMCA Certified Ratings Seal for Sound and Air Performance.

**Construction** - Fan shall be of welded and bolted construction utilizing corrosion resistant fasteners. Housing shall be minimum 12 gauge Lorenized™ steel with integral inlet and outlet flanges. The fan housing shall include an access door that provides unrestricted access to the motor and wheel. Mounting brackets shall be welded to the outer housing to accommodate universal mounting feet for vertical or horizontal installation. Unit shall bear an engraved aluminum nameplate and shall be shipped in ISTA Certified Transit Tested Packaging.

**Wheel** - Wheel shall be centrifugal backward inclined, non-overloading flatblade type. Wheel shall be constructed of 100 percent aluminum, including a precision machined cast aluminum hub. Wheel hub shall be keyed and securely attached to the fan shaft. Wheel inlet shall overlap an aerodynamically efficient aluminum inlet cone to provide maximum performance and efficiency. Wheel shall be balanced in accordance with AMCA Standard 204-05, Balance Quality and Vibration Levels for Fans.

**Coating** - All steel fan components shall be Lorenized™ with an electrostatically applied, baked polyester powder coating. Each component shall be subject to a five stage environmentally friendly wash system, followed by a minimum 2 mil thick baked powder finish. Paint must exceed 1,000 hour salt spray under ASTM B117 test method.

**Motor** - Motor shall be heavy duty type TEFC motor with permanently lubricated sealed ball bearings and furnished at the specified voltage, phase and enclosure.

**Product** - Fan shall be model TCN-D as manufactured by Loren Cook Company of Springfield, Missouri.

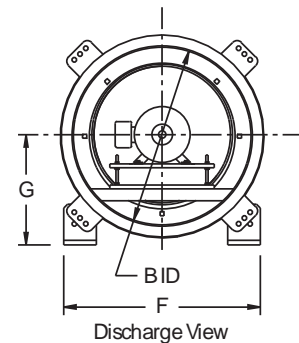
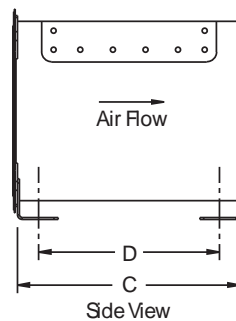
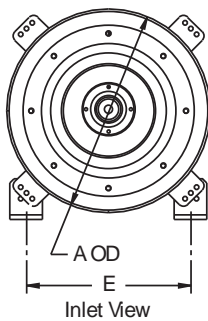

## TCN-D Dimension Data

Size	A	B	C	D	E	F	G	Max. Motor Frame	Approx. Ship Wt.*
60	19	16	22	18-3/8	14-7/8	17-7/8	10-7/8	145T	80
70	19	16	22	18-3/8	14-7/8	17-7/8	10-7/8	145T	80
80	19	16	22	18-3/8	14-7/8	17-7/8	10-7/8	145T	80
100	19	16	22	18-3/8	14-7/8	17-7/8	10-7/8	145T	80
120	21	18	23	19-3/8	16-1/4	19-1/4	10-7/8	184T	105
135	24	21	24-1/2	19-7/8	18-3/8	21-3/8	13-1/16	184T	130
150	27	24	27	22-1/2	20-1/2	23-1/2	14-1/2	215T	155
165	29	26	28-1/2	23	23	27	15-3/4	215T	185

All dimensions in inches. \*Weight in pounds, based on heaviest standard motor.

## Tubular Centrifugal Inline Fan Belt Drive



- Description** - Fan shall be duct mounted, belt driven tubular centrifugal inline.
- Certifications** - Fan shall be listed by Underwriters Laboratories (UL 705 and UL listed for Canada, cUL 705). Fan shall bear the AMCA Certified Ratings Seal for Sound and Air Performance.
- Construction** - Fan shall be of welded and bolted construction utilizing corrosion resistant fasteners. Housing shall be minimum 12 gauge Lorenized™ steel with integral inlet and outlet flanges. The fan housing shall include an inspection door, oriented 180° from the motor, that provides access to the fan for cleaning or inspection. Adjustable motor plate shall utilize threaded studs for positive belt tensioning. Extended lube lines shall be furnished for lubrication of fan bearings. Mounting brackets shall be welded to the outer housing to accommodate universal mounting feet for vertical or horizontal installation. Unit shall bear an engraved aluminum nameplate and shall be shipped in ISTA Certified Transit Tested Packaging.
- Wheel** - Wheel shall be centrifugal backward inclined, non-overloading flatblade type. Wheel shall be constructed of 100 percent aluminum, including a precision machined cast aluminum hub. Wheel hub shall be keyed and securely attached to the fan shaft. Wheel inlet shall overlap an aerodynamically efficient aluminum inlet cone to provide maximum performance and efficiency. Wheel shall be balanced in accordance with AMCA Standard 204-05, Balance Quality and Vibration Levels for Fans.
- Coating** - All steel fan components shall be Lorenized™ with an electrostatically applied, baked polyester powder coating. Each component shall be subject to a five stage environmentally friendly wash system, followed by a minimum 2 mil thick baked powder finish. Paint must exceed 1,000 hour salt spray under ASTM B117 test method.
- Motor** - Motor shall be NEMA design B with class B insulation rated for continuous duty and furnished at the specified voltage, phase and enclosure.
- Bearings** - Bearings shall be designed and tested specifically for use in air handling applications. Construction shall be regreasable ball type in a cast iron pillowblock housing selected for a minimum L10 life in excess of 80,000 hours at maximum cataloged operating speed.
- Belts and Drives** - Belts shall be oil and heat resistant, static conducting. Drives shall be precision machined cast iron type, keyed and securely attached to the wheel and motor shafts. Drives shall be sized for 150 percent of the installed motor horsepower. The variable pitch motor drive must be factory set to the specified fan RPM.
- Product** - Fan shall be model TCN-B as manufactured by Loren Cook Company of Springfield, Missouri.



Loren Cook Company certifies that the TCN-B shown herein is licensed to bear the AMCA Seal. The ratings shown are based on tests and procedures performed in accordance with AMCA Publication 211 and AMCA Publication 311 and comply with the requirements of the AMCA Certified Ratings Program.



Type TCN-B is furnished standard with UL 705 and cUL 705 listings (Power Ventilator/ZACT) when furnished with factory supplied motor.

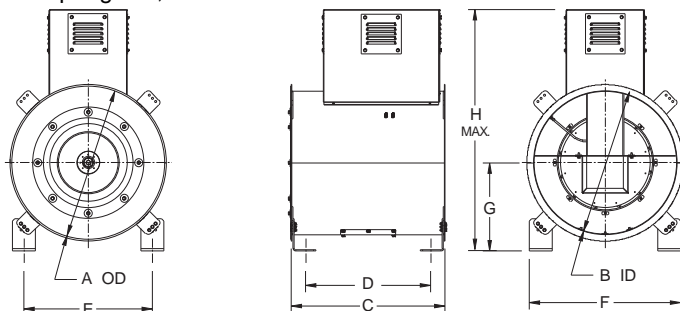

**TCN-B** Dimension Data

Size	A	B	C	D**	E	F	G	H	Max. Motor Frame	Approx. Ship Wt.*
60	19	16	22	18-3/8	14-7/8	17-7/8	10-7/8	30-5/8	143T	125
70	19	16	22	18-3/8	14-7/8	17-7/8	10-7/8	30-5/8	143T	125
80	19	16	22	18-3/8	14-7/8	17-7/8	10-7/8	30-5/8	143T	125
100	19	16	22	18-3/8	14-7/8	17-7/8	10-7/8	30-5/8	143T	125
120	21	18	23	19-3/8	16-1/4	19-1/4	10-7/8	32-3/16	145T	167
135	24	21	24-1/2	19-7/8	18-3/8	21-3/8	13-7/16	36-3/4	145T	206
150	27	24	27	22-1/2	20-1/2	23-1/2	14-1/2	43-1/4	145T	250
165	29	26	28-1/2	23	23	27	15-3/4	45-3/4	182T	295
180	31	28	31	26-3/8	24-3/8	28-3/8	16-7/16	47-3/4	182T	340
195	34	31	33-1/4	27-5/8	27-5/8	32-5/8	19-1/16	52-3/16	182T	390
210	37	34	34-1/2	29	30	35	20-1/4	55-1/8	182T	440
225	39	36	35-1/2	29-7/8	32-1/2	37-1/2	22-1/2	62-1/8	184T	500
245	43	40	41	35-3/8	35-3/8	40-3/8	24	65-7/8	213T	580
270	48	44	46-1/2	51-7/8	40	45-1/2	25-3/4	71-5/8	213T	690
300	52	48	48-1/4	53-5/8	42	47-1/2	27-3/4	75-7/8	215T	840
330	56	52	52	57-3/8	43	50-7/16	30-1/4	80-1/2	215T	990
365	58	54	54	59-3/8	46-3/8	51-7/8	31-15/16	83-5/16	215T	1160
402	64	60	59-1/2	64-7/8	50-9/16	56-1/16	35	92-5/8	215T	1360
445	70	66	66	71-3/8	54-13/16	60-5/16	38-3/16	99-1/16	254T	1630
490	77	73	72-1/2	77-7/8	59-3/4	65-1/4	41-5/8	106-1/4	254T	1900

All dimensions in inches. \*Weight in pounds, less motor. \*\*Feet turned out on sizes 225-490.



# TCNH-D Specifications and Dimension Data

## Tubular Centrifugal Inline Fan Heavy Duty Direct Drive



Loren Cook Company certifies that the TCNH-D shown herein are licensed to bear the AMCA Seal. The ratings shown are based on tests and procedures performed in accordance with AMCA Publication 211 and AMCA Publication 311 and comply with the requirements of the AMCA Certified Ratings Program.



Type TCNH-D is furnished standard with UL 705 and cUL 705 listings (Power Ventilator/ZACT).

**Description** - Fan shall be duct mounted, direct drive tubular centrifugal inline.

**Certifications** - Fan shall be listed by Underwriters Laboratories (UL 705 and UL listed for Canada, cUL 705). Fan shall bear the AMCA Certified Ratings Seal for Sound and Air Performance.

**Construction** - Fan shall be of welded and bolted construction utilizing corrosion resistant fasteners. Housing shall be minimum 12 gauge Lorenized™ steel with integral inlet and outlet flanges. The fan housing shall include an access door that provides unrestricted access to the motor and wheel. Mounting brackets shall be welded to the outer housing to accommodate universal mounting feet for vertical or horizontal installation. Unit shall bear an engraved aluminum nameplate and shall be shipped in ISTA Certified Transit Tested Packaging.

**Wheel** - Wheel shall be steel centrifugal backward inclined, non-overloading flat blade type. Blades shall be continuously welded to the backplate and deep spun inlet shroud. Wheel hub shall be keyed and securely attached to the fan shaft. Wheel inlet shall overlap an aerodynamically efficient aluminum inlet cone to provide maximum performance and efficiency. Wheel shall be balanced in accordance with AMCA Standard 204-05, Balance Quality and Vibration Levels for Fans.

**Coating** - All steel fan components shall be Lorenized™ with an electrostatically applied, baked polyester powder coating. Each component shall be subject to a five stage environmentally friendly wash system, followed by a minimum 2 mil thick baked powder finish. Paint must exceed 1,000 hour salt spray under ASTM B117 test method.

**Motor** - Motor shall be heavy duty type TEFC motor with permanently lubricated sealed ball bearings and furnished at the specified voltage, phase and enclosure.

**Product** - Fan shall be model TCNH-D as manufactured by Loren Cook Company of Springfield, Missouri.

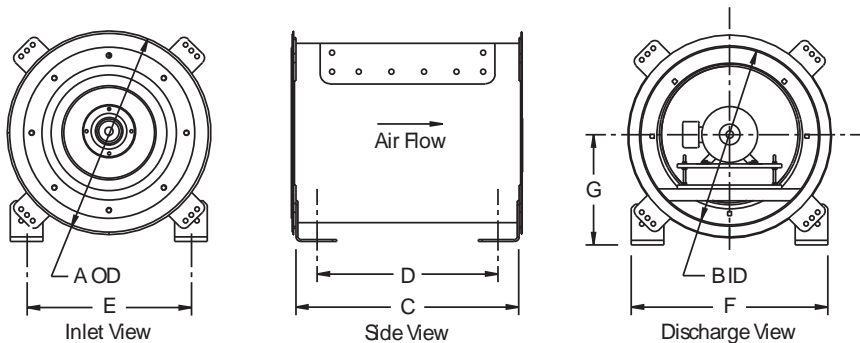

### TCNH-D Dimension Data

Size	A	B	C	D	E	F	G	Max. Motor Frame	Approx. Ship Wt.-Lbs.*
60	19	16	22	18-3/8	14-7/8	17-7/8	10-7/8	145T	87
70	19	16	22	18-3/8	14-7/8	17-7/8	10-7/8	145T	87
80	19	16	22	18-3/8	14-7/8	17-7/8	10-7/8	145T	87
100	19	16	22	18-3/8	14-7/8	17-7/8	10-7/8	145T	87
120	21	18	23	19-3/8	16-1/4	19-1/4	10-7/8	184T	120
135	24	21	24-1/2	19-7/8	18-3/8	21-3/8	13-1/16	184T	148
150	27	24	27	22-1/2	20-1/2	23-1/2	14-1/2	215T	186
165	29	26	28-1/2	23	23	27	15-3/4	215T	210

All dimensions in inches. \*Weight in pounds, based on heaviest standard motor.

## Tubular Centrifugal Inline Fan Heavy Duty Belt Drive



- Description** - Fan shall be duct mounted, belt driven tubular centrifugal inline.
- Certifications** - Fan shall be listed by Underwriters Laboratories (UL 705 and UL listed for Canada, (cUL 705). Fan shall bear the AMCA Certified Ratings Seal for Sound and Air Performance.
- Construction** - Fan shall be of welded and bolted construction utilizing corrosion resistant fasteners. Housing shall be minimum 12 gauge Lorenized™ steel with integral inlet and outlet flanges. The fan housing shall include an inspection door, oriented 180° from the motor, that provides access to the fan for cleaning or inspection. Adjustable motor plate shall utilize threaded studs for positive belt tensioning. Extended lube lines shall be furnished for lubrication of fan bearings. Mounting brackets shall be welded to the outer housing to accommodate universal mounting feet for vertical or horizontal installation. Unit shall bear an engraved aluminum nameplate and shall be shipped in ISTA Certified Transit Tested Packaging.
- Wheel** - Wheel shall be steel centrifugal backward inclined, non-overloading flat blade type. Blades shall be continuously welded to the backplate and deep spun inlet shroud. Wheel hub shall be keyed and securely attached to the fan shaft. Wheel inlet shall overlap an aerodynamically efficient aluminum inlet cone to provide maximum performance and efficiency. Wheel shall be balanced in accordance with AMCA Standard 204-05, Balance Quality and Vibration Levels for Fans.
- Coating** - All steel fan components shall be Lorenized™ with an electrostatically applied, baked polyester powder coating. Each component shall be subject to a five stage environmentally friendly wash system, followed by a minimum 2 mil thick baked powder finish. Paint must exceed 1,000 hour salt spray under ASTM B117 test method.
- Motor** - Motor shall be NEMA design B with class B insulation rated for continuous duty and furnished at the specified voltage, phase and enclosure.
- Bearings** - Bearings shall be designed and tested specifically for use in air handling applications. Construction shall be regreasable ball or roller type in a cast iron pillowblock housing selected for a minimum L10 life in excess of 80,000 hours at maximum cataloged operating speed.
- Belts and Drives** - Belts shall be oil and heat resistant, static conducting. Drives shall be precision machined cast iron type, keyed and securely attached to the wheel and motor shafts. Drives shall be sized for 150 percent of the installed motor horsepower. The variable pitch motor drive must be factory set to the specified fan RPM.
- Product** - Fan shall be model TCNH-B as manufactured by Loren Cook Company of Springfield, Missouri.



Loren Cook Company certifies that the TCNH-B shown herein are licensed to bear the AMCA Seal. The ratings shown are based on tests and procedures performed in accordance with AMCA Publication 211 and AMCA Publication 311 and comply with the requirements of the AMCA Certified Ratings Program.



Type TCNH-B is furnished standard with UL 705 and cUL 705 listings (Power Ventilator/ZACT) when furnished with factory supplied motor.

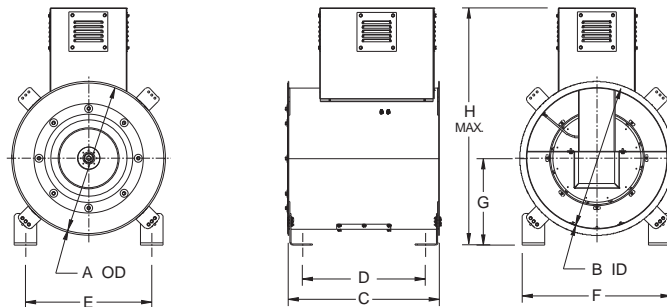

**TCNH-B Dimension Data**

Size	A	B	C	D**	E	F	G	H	Max. Motor Frame	Approx. Ship Wt.*
60	19	16	22	18-3/8	14-7/8	17-7/8	10-7/8	30-5/8	145T	130
70	19	16	22	18-3/8	14-7/8	17-7/8	10-7/8	30-5/8	145T	130
80	19	16	22	18-3/8	14-7/8	17-7/8	10-7/8	30-5/8	145T	130
100	19	16	22	18-3/8	14-7/8	17-7/8	10-7/8	30-5/8	145T	130
120	21	18	23	19-3/8	16-1/4	19-1/4	10-7/8	32-3/16	184T	180
135	24	21	24-1/2	19-7/8	18-3/8	21-3/8	13-7/16	36-3/4	184T	225
150	27	24	27	22-1/2	20-1/2	23-1/2	14-1/2	43-1/4	184T	270
165	29	26	28-1/2	23	23	27	15-3/4	45-3/4	184T	320
180	31	28	31	26-3/8	24-3/8	28-3/8	16-7/16	47-3/4	213T	370
195	34	31	33-1/4	27-5/8	27-5/8	32-5/8	19-1/16	52-3/16	213T	430
210	37	34	34-1/2	29	30	35	20-1/4	55-1/8	213T	490
225	39	36	35-1/2	29-7/8	32-1/2	37-1/2	22-1/2	62-1/8	213T	550
245	43	40	41	35-3/8	35-3/8	40-3/8	24	65-7/8	215T	640
270	48	44	46-1/2	51-7/8	40	45-1/2	25-3/4	71-5/8	215T	760
300	52	48	48-1/4	53-5/8	42	47-1/2	27-3/4	75-7/8	254T	920
330	56	52	52	57-3/8	43	50-7/16	30-1/4	80-1/2	254T	1090
365	58	54	54	59-3/8	46-3/8	51-7/8	31-15/16	83-5/16	256T	1300
402	64	60	59-1/2	64-7/8	50-9/16	56-1/16	35	92-5/8	256T	1540
445	70	66	66	71-3/8	54-13/16	60-5/16	38-3/16	99-1/16	326T	1840
490	77	73	72-1/2	77-7/8	59-3/4	65-1/4	41-5/8	106-1/4	326T	2180

All dimensions in inches. \*Weight in pounds, less motor. \*\*Feet turned out on sizes 225-490.



# Construction Information

## Material Gauges and Shaft Diameters for TCN Fans

Unit	Outer Housing	Shaft Dia.	
		TCN-B	TCNH-B
100	12 ga.	3/4"	1"
120			1-3/16"
135			
150			
165		1"	1-7/16"
180			
195			
210	10 ga.	1"	1-7/16"
225		1-3/16"	1-11/16"
245			
270			
300		1-7/16"	2-3/16"
330			
365			
402		1-15/16"	2-7/16"
445			
490			

## AMCA Spark Resistant Construction

Type	Description	Required Options		
		TCN-B	TCNH-B	TCN-D / TCNH-D
A	All parts of the Air Moving Device (AMD) in contact with the air or gas being handled shall be made of non-ferrous material.	All Aluminum Construction S.S. Shaft and Hardware Shaft Seal	All Aluminum Construction S.S. Shaft and Hardware Shaft Seal	All Aluminum Construction S.S. Shaft and Hardware Explosion-Proof Motor Required
B	The AMD shall have an entirely non-ferrous wheel or impeller and non-ferrous ring about the opening through which the shaft passes.	Shaft Seal	Aluminum Wheel Shaft Seal	Explosion-Proof Motor Aluminum Wheel (TCNH-D)
C	The AMD shall be so constructed that a shift of the wheel or impeller or shaft will not permit two ferrous parts of the AMD to rub or strike.	Shaft Seal	Shaft Seal	

NOTES: (1) Bearings shall not be placed in the air or gas stream. (2) The user shall electrically ground all AMD parts.

## Wheel Weights and WK<sup>2</sup> for TCN Steel and Aluminum Flatblade Wheels

Unit Size	Aluminum Wheel				Steel Wheel	
	TCN		TCN-H		TCN-H	
	Wheel Wt.	WK <sup>2</sup>	Wheel Wt.	WK <sup>2</sup>	Wheel Wt.	WK <sup>2</sup>
60-100	4.0	0.5	5	0.3	13	1
120	4.9	0.7	6	1	17	2
135	5.8	0.9	7	1	20	3
150	6.7	1.2	8	1	23	4
165	7.6	1.6	9	2	29	7
180	8.7	2.1	15	3	48	11
195	9.8	2.7	17	5	51	14
210	11.7	3.8	18	2	60	21
225	15.0	6.8	21	8	65	27
245	17.4	9.0	24	12	74	37
270	21.5	12.8	28	18	96	62
300	31.5	33.9	47	31	143	98
330	38.2	40.5	53	44	168	148
365	44.3	50.7	63	69	193	217
402	56.2	65.8	82	120	266	390
445	66.2	88.2	128	192	396	613
490	77.9	120.1	143	273	451	882

For proper motor selection you must give consideration to starting torque requirements along with the operating BHP. The above chart lists the WK<sup>2</sup> factor for different wheel sizes. In some cases it may be necessary to provide a larger horsepower motor in order to bring the fan to speed, even though it may not be indicated by operating BHP.

The following formula can be applied to determine the required motor starting torque.

$$WK_M^2 = WK_F^2 (FRPM/MRPM)^2 \quad (1.1)$$

### Where

WK<sub>M</sub><sup>2</sup> - Is the moment of inertia required at the motor shaft, LB-Ft<sup>2</sup>

WK<sub>F</sub><sup>2</sup> - Is the moment of inertia of the fan, LB-Ft<sup>2</sup>

FRPM - Is the fan RPM

MRPM - Is the motor RPM

Motor starting torque can vary greatly among motor manufacturers, the available WK<sub>M</sub><sup>2</sup> at the motor should be obtained from the motor manufacturer.

## Horizontal Mounting

Horizontal mounting configurations are provided with standard mounting feet for both ceiling and floor applications. The mounting configuration and the motor position can be changed in the field. Mounting rails are recommended for horizontal configurations with motor positions 'C' and 'G'. All units are shipped with the motor in position 'A'. Motor position is determined by viewing fan outlet.

### Ceiling

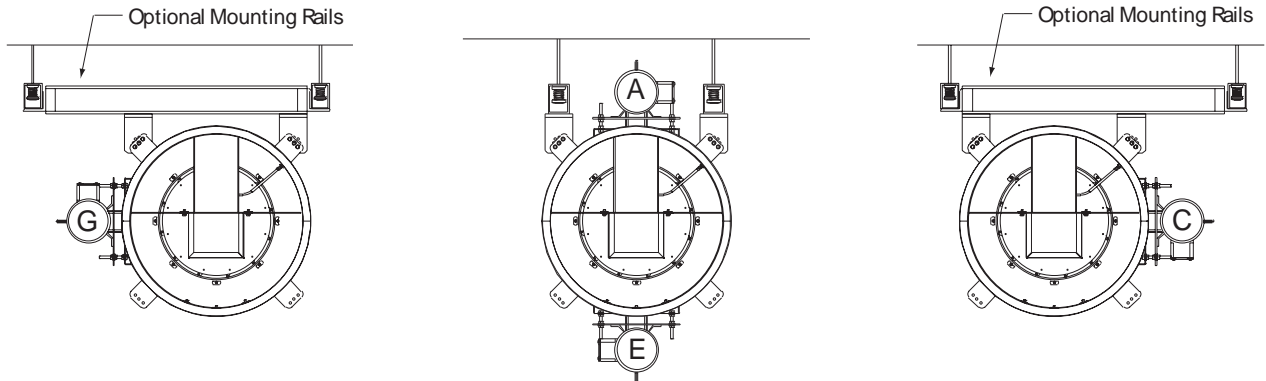

### Floor

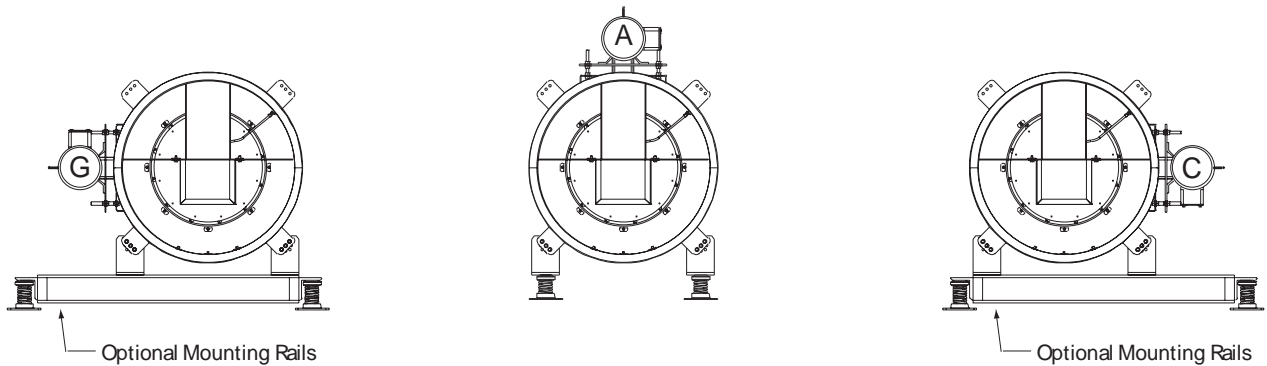

## Vertical Mounting

Vertical mounting configurations are provided with standard mounting brackets welded to each end. The brackets allow a unit to be installed in either ceiling or floor configuration, in both upblast and downblast applications. Mounting rails are suggested for any vertical installation. Figures below reflect an upblast configuration.

### Ceiling

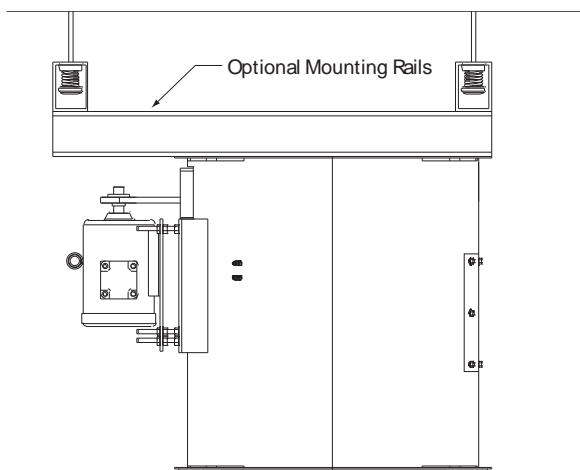

### Floor

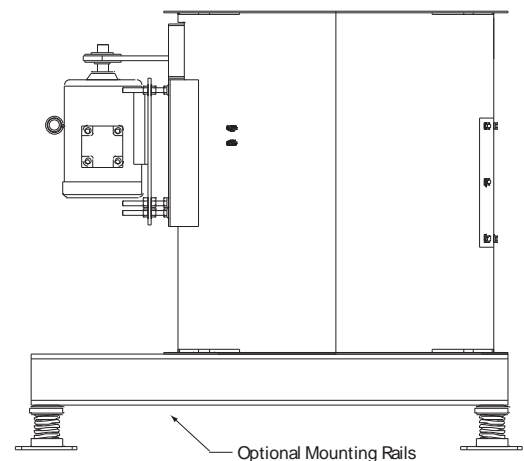

# Accessories

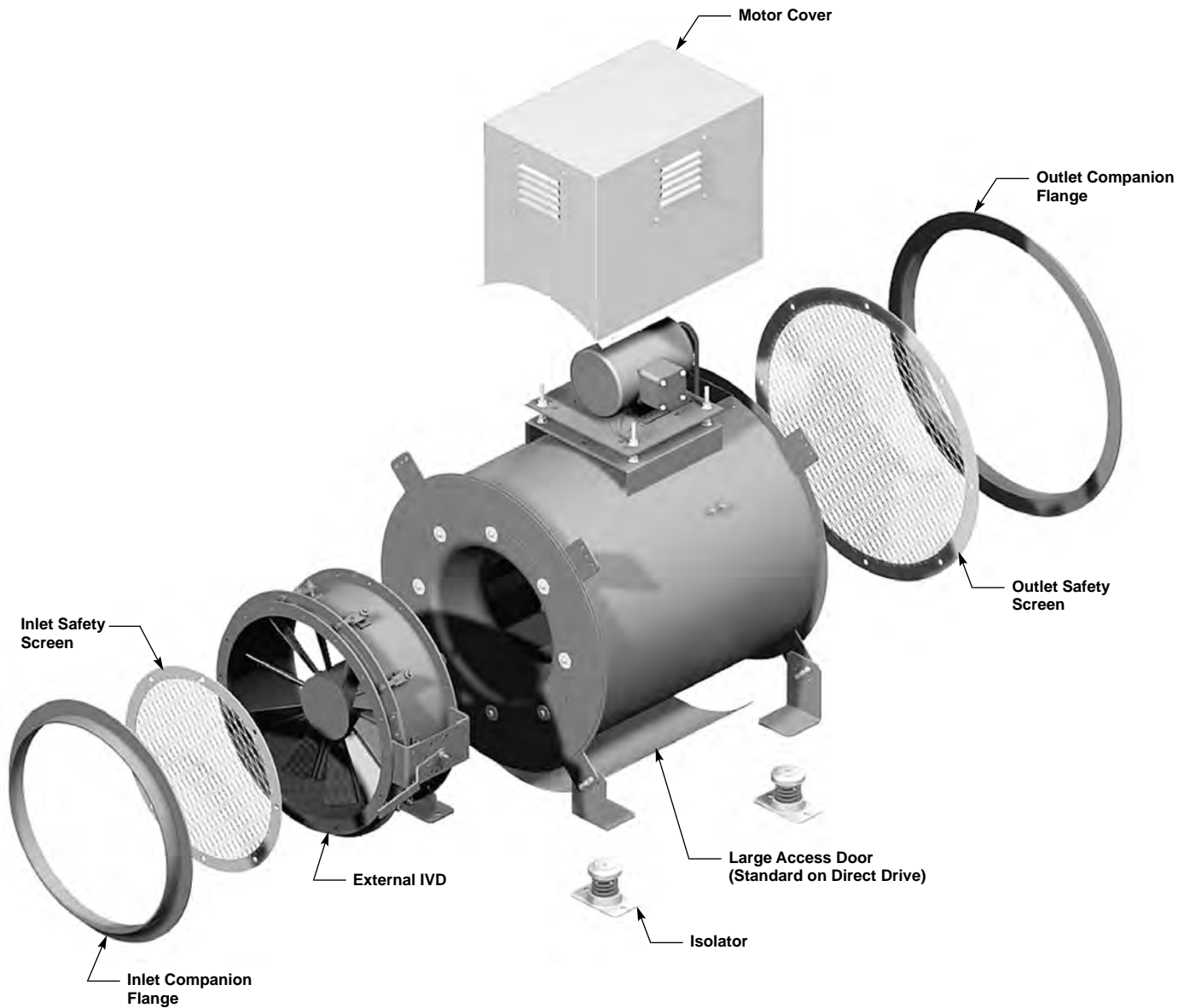

## Large Access Door

A large access door is an available option on the TCN-B and is standard on the TCN-D. This door provides unrestricted access to the bearings, shaft, and wheel of the TCN-B for ease of maintenance and cleaning without removing the fan from the surrounding ductwork.

## Belt Guard

A Belt Guard is designed to cover the top, front and sides of the drive assembly. The belt guard has an open back to allow for inspection or belt tightening and is factory installed.

## Motor Cover

The motor cover encloses the motor and drive assembly and serves as an OSHA belt guard. The motor cover is factory installed.

## Inlet/Outlet Safety Screens

Inlet/Outlet safety screens are available to protect personnel and prevent debris from entering the fan. Safety screens are constructed of expanded metal and are factory installed. Cataloged performance is based on fans without safety screens.

## Mounting Rails

Mounting rails are available for applications where the motor center of gravity is offset with respect to the fan center of gravity. The mounting recommendations are shown page 9.

## Flexible Duct Connector

The flexible duct connector provides a flexible connection between the fan and the attached ductwork. This flexible connection reduces the transmission of noise and vibration to the ductwork as well as allowing for slight misalignment and easy removal of the fan without disturbing the rigid ductwork. The connector is constructed of reinforced neoprene fabric and aluminum bands.

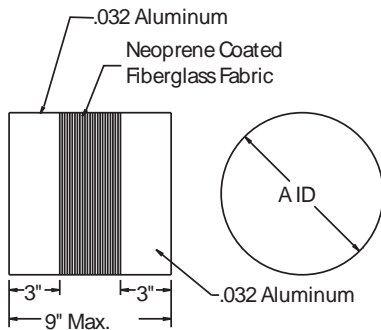

Size	A
60	16-1/4
70	16-1/4
80	16-1/4
100	16-1/4
120	18-1/4
135	21-1/4
150	24-1/4
165	26-1/4
180	28-1/4
195	31-1/4
210	34-1/4
225	36-1/2
245	40-1/2
270	44-1/2
300	48-1/2
330	52-1/2
365	54-1/2
402	60-1/2
445	66-1/2
490	73-1/2

All dimensions in inches.

## Inlet/Outlet Companion Flange

Inlet/outlet companion flanges are available for use in conjunction with the optional flanged inlet/outlet. The companion flanges are attached to the adjacent ductwork to provide an exact mate to the flanged connection on the fan.

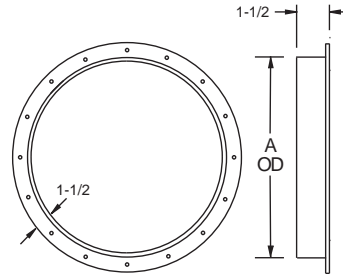

Size	A
60	16
70	16
80	16
100	16
120	18
135	21
150	24
165	26
180	28
195	31
210	34
225	36
245	40
270	44
300	48
330	52
365	54
402	60
445	66
490	73

All dimensions in inches.

## External IVD

An external inlet vane damper, IVD, is used to provide precise air volume control while maintaining maximum efficiency and stable operation at reduced load conditions. The IVD may be used with a maximum airstream temperature of 200° F. An external IVD is factory mounted and provided with an adjustment lever for manual or actuated control.

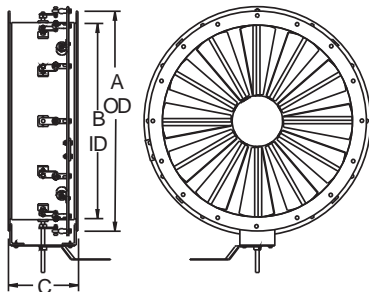

Size	A	B	C
120	15-7/8	12-7/8	10
135	17-3/8	14-3/8	
150	18-7/8	15-7/8	
165	20-3/8	17-3/8	
180	21-7/8	18-7/8	
195	23	20	
210	24-3/4	21-3/4	
225	26-1/4	23-1/4	
245	28-1/4	24-1/4	
270	31-1/4	27-1/4	
300	34-1/4	30-1/4	
330	37-1/4	33-1/4	
365	40-3/4	36-3/4	
402	44-1/2	40-1/2	
445	48-3/4	44-3/4	
490	54-1/4	50-1/4	

All dimensions in inches.

## Disconnect Switches

- NEMA 1 (Lockable) - Indoor, general purpose with lockable switch.
- NEMA 1 - Indoor, general purpose.
- NEMA 3R - Exterior mount, weather resistant.
- NEMA 4 - Water tight, dust tight.
- NEMA 1 (Heavy Duty) - Indoor heavy duty.



**NEMA 1 (Lockable)**



**NEMA 1**



**NEMA 3R**



**NEMA 4**



**NEMA 1 (Heavy Duty)**

# Accessories

## Rubber-in-Shear Isolator – Ceiling Mounted

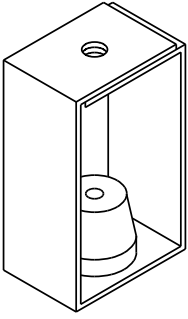

Unit	Rated Load
RC-75	75
RC-125	125
RC-175	175
RC-300	300
RC-450	450
RC-700	700
RC-1100	1100
RC-2000	2000

## Rubber-in-Shear Isolator – Floor Mounted

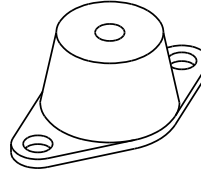

Unit	Rated Load
RF-55	55
RF-120	120
RF-220	220
RF-375	375
RF-600	600
RF-1100	1100
RF-2250	2250

## Spring Isolator – Ceiling Mounted

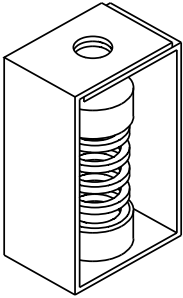

Unit	Rated Load	Spring Rate (lbs./in.)
SC-35	35	23
SC-70	70	51
SC-125	125	100
SC-245	245	206
SC-370	370	370
SC-500	500	500
SC-1000	1000	870
SC-1700	1700	1700

## Free Standing Spring Isolator – Floor Mounted

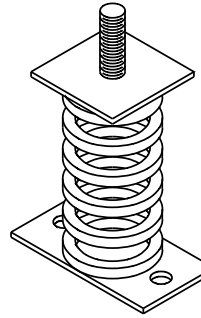

Unit	Rated Load	Spring Rate (lbs./in.)
SF-70	70	51
SF-120	120	98
SF-220	220	196
SF-370	370	366
SF-625	625	419
SF-1250	1250	1096
SF-1700	1700	1700

## Housed Spring Isolator – Floor Mounted

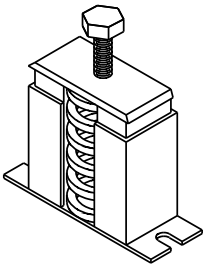

Unit	Rated Load	Spring Rate (lbs./in.)
HF-120	120	98
HF-220	220	196
HF-320	320	302
HF-370	370	366
HF-500	500	500
HF-700	700	700
HF-800	800	588
HF-1000	1000	826
HF-1250	1250	1098
HF-1700	1700	1700

## Restrained Spring Isolator – Floor Mounted

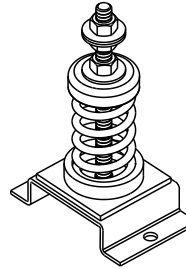

Unit	Rated Load	Spring Rate (lbs./in.)
RS-70	70	51
RS-120	120	98
RS-220	220	196
RS-370	370	366
RS-625	625	419
RS-1250	1250	1096
RS-1700	1700	1700

## Standard Coatings

**Lorenized®** is an electrostatically applied, baked polyester powder coating. Each component shall be subject to a five stage environmentally friendly wash system, followed by a minimum 2 mil thick baked powder finish. Coating must exceed 1,000 hour salt spray under ASTM B117 test method.

## Optional Coatings

**Cook Epoxy Powder** is an electrostatically applied, baked epoxy powder coating. Final coating thickness is 2.5 – 3.5 mils. For outdoor applications an optional UV resistant topcoat is available to prevent cosmetic chalking of the coating.

**Cook Phenolic Epoxy Powder** is an electrostatically applied, baked phenolic epoxy powder coating. Final coating thickness is 2 – 4 mils. For outdoor applications an optional UV resistant topcoat is required to prevent deterioration of the coating.

**Air Dry Phenolic (Heresite VR-504)** is a conventional spray applied phenolic resin coating. Final coating thickness is 4 – 6 mils. For outdoor applications an optional UV resistant topcoat (Heresite UC-5500) is required to prevent deterioration of the coating.

Refer to the corrosion resistance guide in the Compute-A-Fan software for a listing of the coatings above and their resistance to a variety of chemicals. Additional special coatings are available.

## Alternate Construction Materials

Aluminum and stainless steel constructions are available. Contact factory for additional information.

**TCN-D Data**

Unit	Max. BHP	RPM	Motor HP	CFM vs. Static Pressure												
				0.0"	0.250"	0.500"	0.750"	1.000"	1.250"	1.500"	1.750"	2.000"	2.500"	2.750"	3.000"	
60TCN11D	.03	1140	1/4	145	84											
60TCN17D	.09	1725	1/4	220	185	140	82									
60TCN34D	.75	3450	3/4	440	419	402	386	371	354	334	311	280	236	206	163	
70TCN11D	.03	1140	1/4	241	142											
70TCN17D	.10	1725	1/4	365	305	237	139									
70TCN34D	.82	3450	1	730	702	673	642	610	578	544	509	473	397	336	277	
80TCN11D	.04	1140	1/4	460	309											
80TCN17D	.14	1725	1/4	696	619	496										
80TCN34D	1.08	3450	1	1392	1360	1324	1284	1239	1186	1124	1054	992	892	839		
100TCN11D	.05	1140	1/4	675	449											
100TCN17D	.17	1725	1/4	1021	897	733	465									
100TCN34D	1.39	3450	1-1/2	2042	1975	1912	1853	1793	1732	1665	1574	1466	1276	1139	930	
120TCN11D	.10	1140	1/4	1054	834											
120TCN17D	.37	1725	1/3	1595	1455	1307	1138	843								
120TCN34D	2.94	3450	3	3190	3121	3051	2981	2910	2838	2765	2691	2614	2455	2370	2277	
135TCN11D	.21	1140	1/4	1780	1503	1079										
135TCN17D	.71	1725	3/4	2693	2543	2343	2101	1847	1431							
150TCN11D	.32	1140	1/3	2359	2011	1653	1053									
150TCN17D	1.11	1725	1-1/2	3569	3292	3098	2897	2653	2383	2032	1485					
165TCN11D	.57	1140	3/4	3311	3009	2625	2170									
165TCN17D	1.96	1725	2	5010	4825	4618	4386	4128	3855	3563	3234	2547				

Performance certified is for installation type B: free inlet, ducted outlet. Performance ratings do not include the effects of appurtenances (accessories).  
Sound data - pages 34-37.

**TCNH-D Data**

Unit	Max. BHP	RPM	Motor HP	CFM vs. Static Pressure												
				0.0"	0.250"	0.500"	0.750"	1.000"	1.250"	1.500"	1.750"	2.000"	2.500"	2.750"	3.000"	
60TCNH11D	.03	1140	1/4	147	88											
60TCNH17D	.09	1725	1/4	222	187	146	85									
60TCNH34D	.74	3450	3/4	444	427	409	392	374	356	337	315	293	245	211	170	
70TCNH11D	.03	1140	1/4	238	144											
70TCNH17D	.10	1725	1/4	360	310	240	150									
70TCNH34D	.81	3450	1	719	700	677	651	621	586	550	514	480	401	351	301	
80TCNH11D	.04	1140	1/4	476	333											
80TCNH17D	.13	1725	1/4	721	631	527	451									
80TCNH34D	1.07	3450	1-1/2	1442	1400	1356	1310	1261	1211	1160	1105	1053	978	944	902	
100TCNH11D	.04	1140	1/4	583	419											
100TCNH17D	.15	1725	1/4	882	773	667	524									
100TCNH34D	1.21	3450	1-1/2	1764	1709	1655	1601	1547	1493	1439	1387	1334	1216	1146	1048	
120TCNH11D	.10	1140	1/4	1005	819											
120TCNH17D	.33	1725	1/2	1520	1395	1276	1133	946								
120TCNH34D	2.67	3450	3	3040	2974	2911	2850	2790	2731	2672	2613	2552	2420	2345	2266	
135TCNH11D	.16	1140	1/4	1524	1283	959										
135TCNH17D	.56	1725	3/4	2305	2156	1991	1818	1610	1333							
150TCNH11D	.29	1140	1/3	2177	1926	1655	1256									
150TCNH17D	1.0	1725	1-1/2	3294	3133	2964	2788	2611	2418	2148						
165TCNH11D	.57	1140	3/4	3036	2707	2444	2071									
165TCNH17D	1.97	1725	2	4594	4332	4145	3977	3809	3604	3352	3101					

Performance certified is for installation type B: free inlet, ducted outlet. Performance ratings do not include the effects of appurtenances (accessories).  
Sound data - pages 34-37.



# 60TCN-B/TCNH-B Data

**Wheel Diameter = 10"**  
**Tip Speed (FPM) = 2.62 x RPM**  
**Max. BHP =**  
 TCN-B =  $0.014 \times (\text{RPM}/1000)^3$   
 TCNH-B =  $0.014 \times (\text{RPM}/1000)^3$   
**Outlet Area = 1.4 FT<sup>2</sup>**  
**Outlet Velocity (FPM) = CFM x .71**  
**Max. Motor Frame Size =**  
 TCN-B =143T  
 TCNH-B =145T  
**1140 RPM motor required**  
**on 1150 and lower FRPM**  
**3450 RPM motor required**  
**on 2700 and greater FRPM**

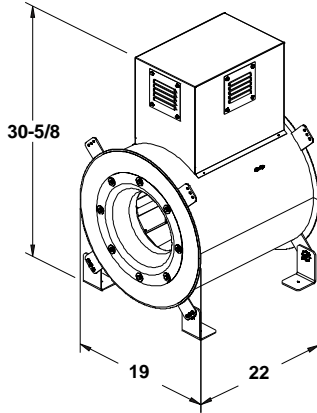

**60 TCN-B**

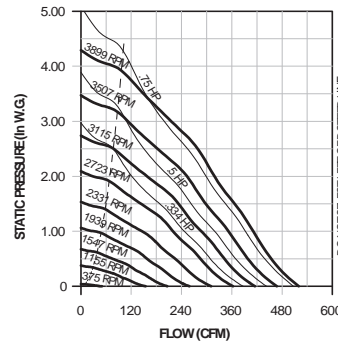

**60 TCNH-B**

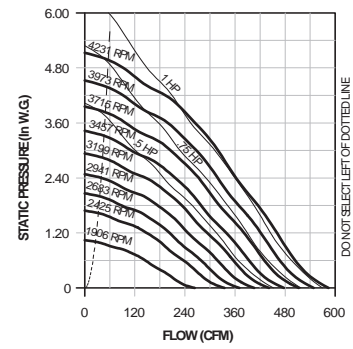

**60 TCN-B**

CFM	OV	0.000" SP		0.250" SP		0.500" SP		0.750" SP		1.000" SP		1.250" SP		1.500" SP		1.750" SP		2.000" SP		2.250" SP		2.500" SP	
		RPM	BHP	RPM	BHP	RPM	BHP	RPM	BHP	RPM	BHP	RPM	BHP	RPM	BHP	RPM	BHP	RPM	BHP	RPM	BHP	RPM	BHP
50	35	375	0.00	1080	.02	1449	.04	1731	.06	1973	.09												
80	57	600	0.00	1195	.02	1562	.05	1846	.08	2085	.11	2295	.15	2484	.18	2658	.22	2821	.26	2974	.30	3122	.34
110	78	825	.01	1362	.04	1676	.06	1959	.10	2197	.14	2408	.18	2599	.22	2774	.27	2937	.31	3089	.36	3233	.41
140	100	1050	.02	1537	.05	1831	.09	2075	.12	2310	.17	2521	.22	2711	.26	2886	.32	3049	.37	3202	.42	3347	.48
170	121	1275	.03	1714	.07	2014	.11	2233	.16	2434	.20	2635	.25	2824	.31	2999	.36	3162	.42	3314	.48	3459	.55
200	142	1500	.05	1913	.10	2185	.15	2418	.20	2602	.25	2772	.30	2943	.35	3113	.42	3275	.48	3428	.55	3573	.62
230	164	1725	.07	2119	.13	2360	.18	2592	.24	2786	.30	2947	.36	3097	.41	3246	.48	3395	.54	3543	.61	3686	.69
260	185	1950	.10	2328	.18	2551	.23	2762	.29	2962	.36	3132	.43	3278	.49	3414	.56	3546	.62	3677	.69	3808	.77
290	207	2175	.14	2539	.23	2753	.29	2942	.35	3131	.43	3308	.50	3462	.58	3598	.65	3722	.72	3842	.79		
320	228	2400	.19	2750	.29	2960	.36	3135	.43	3306	.50	3476	.58	3636	.67	3780	.75						
350	250	2625	.25	2962	.36	3169	.44	3337	.52	3493	.59	3649	.68	3805	.77								
380	271	2850	.32	3174	.44	3379	.53	3542	.62	3690	.70	3833	.78										
410	292	3075	.40	3386	.53	3589	.64	3750	.73	3893	.82												
440	314	3300	.49	3600	.64	3800	.76																
470	335	3525	.60	3811	.75																		
500	357	3750	.72																				

**60 TCNH-B**

CFM	OV	1.000" SP		1.250" SP		1.500" SP		1.750" SP		2.000" SP		2.250" SP		2.500" SP		2.750" SP		3.000" SP		3.500" SP		4.000" SP	
		RPM	BHP	RPM	BHP	RPM	BHP	RPM	BHP	RPM	BHP	RPM	BHP	RPM	BHP	RPM	BHP	RPM	BHP	RPM	BHP	RPM	BHP
30	21	1906	.07																				
50	35	1953	.08	2167	.11	2362	.14	2542	.17	2710	.21	2868	.25	3017	.28	3160	.32	3297	.37				
70	50	2012	.10	2227	.13	2419	.16	2596	.20	2760	.23	2916	.27	3063	.31	3204	.36	3339	.40	3593	.49	3830	.59
90	64	2054	.11	2276	.14	2475	.18	2655	.22	2821	.26	2976	.30	3122	.35	3261	.39	3394	.44	3644	.54	3878	.64
110	78	2112	.12	2320	.16	2516	.20	2700	.24	2871	.29	3030	.33	3180	.38	3321	.43	3454	.48	3705	.58	3937	.69
130	92	2191	.14	2387	.18	2570	.22	2744	.26	2912	.31	3072	.36	3224	.41	3369	.46	3506	.52	3762	.63	3997	.74
150	107	2275	.16	2469	.21	2645	.25	2810	.29	2967	.34	3118	.39	3266	.44	3409	.49	3547	.55	3807	.67	4048	.79
170	121	2367	.18	2553	.23	2728	.28	2890	.33	3042	.38	3186	.43	3325	.48	3461	.53	3592	.59	3847	.71	4089	.84
190	135	2475	.20	2646	.25	2813	.31	2973	.36	3124	.42	3266	.47	3401	.53	3530	.58	3656	.64	3898	.76	4132	.89
210	150	2591	.23	2753	.28	2908	.34	3060	.39	3208	.45	3348	.51	3483	.58	3610	.64	3732	.70	3966	.82	4189	.95
230	164	2709	.27	2869	.32	3016	.37	3157	.43	3297	.49	3433	.56	3566	.62	3693	.69	3815	.76	4044	.89		
250	178	2823	.30	2987	.36	3131	.41	3266	.47	3397	.53	3526	.60	3653	.67	3778	.74	3898	.81	4127	.96		
270	192	2934	.34	3103	.40	3249	.46	3382	.52	3507	.58	3629	.65	3749	.72	3868	.79	3985	.87	4210	1.02		
290	207	3045	.38	3215	.45	3366	.51	3500	.57	3623	.64	3740	.71	3854	.78	3966	.85	4077	.93				
310	221	3158	.43	3325	.50	3479	.56	3617	.63	3742	.70	3857	.77	3968	.84	4075	.92	4181	.99				
330	235	3276	.49	3436	.55	3590	.62	3730	.69	3859	.77	3976	.84	4085	.91	4190	.99						
350	250	3401	.55	3551	.62	3700	.69	3841	.76	3973	.84	4093	.91	4203	.99								
370	264	3529	.62	3670	.69	3813	.76	3952	.84	4084	.91	4207	.99										
390	278	3660	.70	3794	.77	3929	.84	4063	.92	4194	1.00												
410	292	3793	.78	3922	.85	4049	.93	4177	1.00														
430	307	3928	.86	4052	.94	4174	1.02																

Performance certified is for installation type B: free inlet, ducted outlet. Power rating (BHP) does not include drive losses. Performance ratings do not include the effects of appurtenances (accessories).

**70 TCN-B**

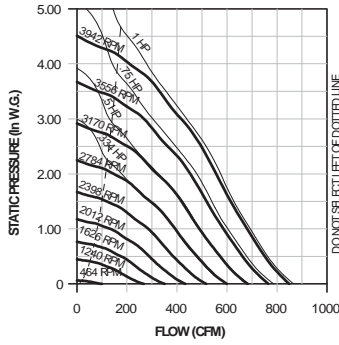

**70 TCNH-B**

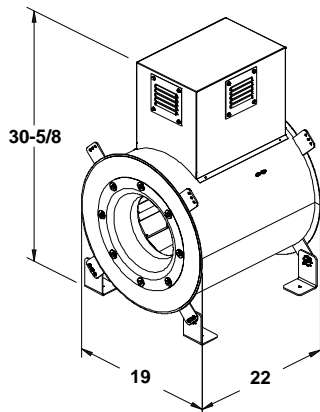
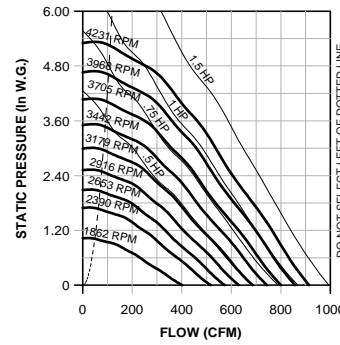

Wheel Diameter = 10"  
 Tip Speed (FPM) = 2.62 x RPM  
 Max. BHP =  
 TCN-B = 0.016 x (RPM/1000)<sup>3</sup>  
 TCNH-B = 0.016 x (RPM/1000)<sup>3</sup>  
 Outlet Area = 1.4 FT<sup>2</sup>  
 Outlet Velocity (FPM) = CFM x 0.71  
 Max. Motor Frame Size = 143T  
 TCN-B = 143T  
 TCNH-B = 145T  
 1140 RPM motor required  
 on 1150 and lower FRPM  
 3450 RPM motor required  
 on 2700 and greater FRPM

**70 TCN-B**

CFM	OV	0.000" SP		0.250" SP		0.500" SP		0.750" SP		1.000" SP		1.250" SP		1.500" SP		1.750" SP		2.000" SP		2.250" SP		2.500" SP			
		RPM	BHP	RPM	BHP	RPM	BHP	RPM	BHP	RPM	BHP	RPM	BHP	RPM	BHP	RPM	BHP	RPM	BHP	RPM	BHP	RPM	BHP	RPM	BHP
100	71	464	0.00	1087	.02	1433	.04	1721	.07	1963	.11	2176	.14												
140	100	650	0.00	1191	.03	1533	.06	1792	.09	2024	.13	2237	.16	2432	.21	2609	.25	2774	.30	2929	.35	3075	.40		
180	128	836	.01	1329	.04	1634	.07	1900	.11	2117	.15	2311	.19	2495	.24	2669	.29	2834	.34	2991	.39	3138	.44		
220	157	1022	.02	1485	.05	1755	.08	2000	.13	2226	.17	2420	.22	2592	.27	2753	.32	2906	.38	3054	.44	3198	.49		
260	185	1207	.03	1646	.07	1901	.11	2118	.15	2325	.20	2523	.25	2702	.30	2862	.36	3010	.42	3149	.48	3283	.55		
300	214	1393	.04	1807	.09	2057	.14	2259	.18	2445	.23	2625	.28	2801	.34	2967	.40	3119	.47	3260	.53	3391	.60		
340	242	1579	.06	1970	.12	2217	.17	2411	.22	2584	.27	2749	.32	2909	.39	3066	.45	3218	.52	3364	.59	3500	.66		
380	271	1765	.08	2137	.15	2377	.21	2569	.26	2735	.32	2889	.37	3037	.44	3181	.50	3322	.58	3462	.65	3598	.73		
420	300	1950	.11	2307	.19	2538	.26	2729	.32	2891	.37	3039	.43	3179	.50	3313	.56	3444	.64	3573	.72	3701	.80		
460	328	2136	.15	2479	.24	2701	.31	2889	.38	3051	.44	3195	.51	3329	.57	3457	.64	3580	.71	3701	.79	3820	.87		
500	357	2322	.19	2652	.29	2866	.37	3050	.45	3211	.52	3354	.59	3485	.66	3608	.72	3726	.80	3841	.88				
540	385	2508	.24	2826	.35	3033	.44	3212	.52	3372	.60	3514	.68	3643	.75	3764	.83	3878	.90						
580	414	2693	.30	3000	.42	3203	.52	3376	.60	3533	.69	3675	.78	3803	.86	3922	.94								
620	442	2879	.37	3177	.50	3374	.60	3541	.70	3695	.79	3835	.89												
660	471	3065	.44	3351	.59	3546	.70	3709	.80	3858	.90														
700	500	3251	.53	3528	.69	3720	.81	3878	.92																
740	528	3437	.63	3703	.80	3892	.93																		
780	557	3622	.73	3880	.92																				

**70 TCNH-B**

CFM	OV	1.000" SP		1.250" SP		1.500" SP		1.750" SP		2.000" SP		2.250" SP		2.500" SP		2.750" SP		3.000" SP		3.500" SP		4.000" SP		
		RPM	BHP	RPM	BHP	RPM	BHP	RPM	BHP	RPM	BHP	RPM	BHP	RPM	BHP	RPM	BHP	RPM	BHP	RPM	BHP	RPM	BHP	
60	42	1862	.08	2073	.10																			
100	71	1912	.09	2124	.12	2315	.16	2491	.19	2654	.23	2807	.27	2951	.31	3089	.35	3220	.39	3468	.48			
140	100	1966	.11	2172	.14	2362	.17	2538	.21	2702	.25	2857	.30	3002	.34	3141	.39	3273	.44	3521	.54	3751	.65	
180	128	2064	.13	2250	.17	2425	.21	2592	.25	2751	.29	2903	.33	3048	.37	3187	.42	3319	.47	3569	.58	3801	.70	
220	157	2171	.15	2360	.20	2527	.24	2681	.29	2827	.33	2969	.38	3106	.42	3240	.47	3369	.52	3616	.63	3847	.75	
260	185	2277	.18	2462	.23	2635	.28	2791	.33	2934	.38	3068	.43	3196	.48	3320	.54	3441	.59	3675	.70	3899	.82	
300	214	2408	.21	2574	.26	2737	.31	2894	.37	3042	.43	3179	.49	3307	.54	3427	.60	3542	.66	3762	.79	3972	.91	
340	242	2551	.25	2709	.30	2857	.35	3000	.41	3143	.47	3282	.53	3413	.60	3537	.67	3654	.74	3871	.87	4073	1.01	
380	271	2693	.30	2852	.35	2994	.41	3128	.46	3258	.52	3386	.59	3513	.66	3638	.73	3758	.80	3981	.95	4184	1.10	
420	300	2832	.35	2994	.41	3138	.47	3268	.53	3391	.59	3511	.65	3628	.72	3743	.79	3859	.87	4083	1.03			
460	328	2971	.40	3134	.47	3280	.53	3412	.60	3534	.67	3648	.73	3759	.80	3867	.87	3973	.95	4185	1.11			
500	357	3111	.47	3272	.54	3419	.61	3554	.68	3677	.75	3791	.82	3899	.89	4003	.97	4104	1.04					
540	385	3255	.54	3412	.61	3558	.69	3693	.77	3818	.84	3934	.92	4043	1.00	4146	1.08							
580	414	3402	.62	3553	.70	3696	.78	3832	.86	3957	.94	4075	1.03	4185	1.11									
620	442	3554	.72	3697	.80	3838	.88	3970	.96	4096	1.05	4214	1.14											
660	471	3711	.82	3847	.90	3981	.99	4110	1.08															
700	500	3872	.93	3999	1.02	4129	1.11																	
740	528	4036	1.05	4157	1.15																			

Performance certified is for installation type B: free inlet, ducted outlet. Power rating (BHP) does not include drive losses. Performance ratings do not include the effects of appurtenances (accessories).

# 80 TCN-B/TCNH-B Data

**Wheel Diameter = 10"**  
**Tip Speed (FPM) = 2.62 x RPM**  
**Max. BHP =**  
**TCN-B = 0.024 x (RPM/1000)<sup>3</sup>**  
**TCNH-B = 0.023 x (RPM/1000)<sup>3</sup>**  
**Outlet Area = 1.4 FT<sup>2</sup>**  
**Outlet Velocity (FPM) = CFM x 0.71**  
**Max. Motor Frame Size =**  
**TCN-B = 143T**  
**TCNH-B = 145T**  
**1140 RPM motor required**  
**on 1150 and lower FRPM**  
**3450 RPM motor required**  
**on 2700 and greater FRPM**

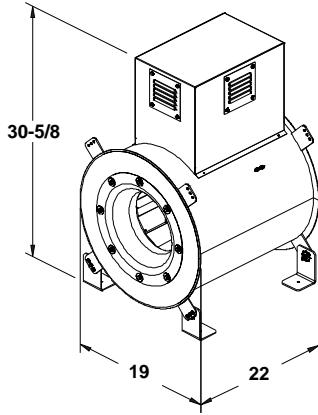

**80 TCN-B**

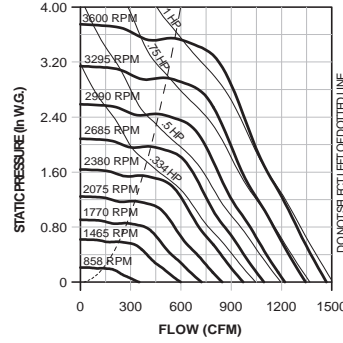

**80 TCNH-B**

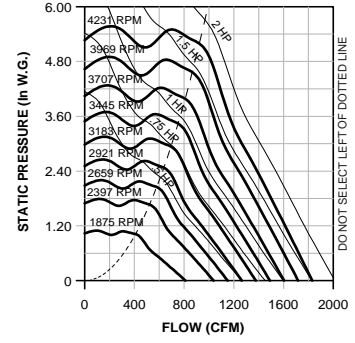

**80 TCN-B**

CFM	OV	0.000" SP		0.250" SP		0.500" SP		0.750" SP		1.000" SP		1.250" SP		1.500" SP		1.750" SP		2.000" SP		2.250" SP		2.500" SP	
		RPM	BHP	RPM	BHP	RPM	BHP	RPM	BHP	RPM	BHP	RPM	BHP	RPM	BHP	RPM	BHP	RPM	BHP	RPM	BHP	RPM	BHP
350	250	858	.01	1236	.04	1458	.07	1695	.11	1930	.16	2142	.21										
410	292	1005	.02	1361	.05	1570	.09	1757	.13	1961	.18	2167	.23	2356	.28								
470	335	1152	.03	1479	.07	1694	.11	1859	.15	2024	.20	2200	.25	2383	.31	2557	.37	2719	.43	2873	.50		
530	378	1299	.04	1597	.09	1822	.13	1979	.17	2123	.22	2269	.28	2424	.34	2586	.40	2746	.47	2898	.54	3042	.61
590	421	1446	.06	1722	.11	1945	.16	2106	.21	2240	.25	2369	.31	2500	.37	2636	.43	2780	.51	2926	.58	3069	.66
650	464	1593	.08	1852	.13	2063	.19	2233	.24	2365	.29	2485	.35	2602	.41	2720	.47	2842	.54	2969	.62	3101	.70
710	507	1740	.10	1985	.16	2180	.22	2357	.28	2492	.34	2609	.40	2718	.45	2825	.52	2933	.59	3043	.66	3156	.75
770	550	1887	.13	2120	.20	2300	.26	2476	.32	2619	.39	2736	.45	2841	.51	2942	.58	3041	.64	3140	.72	3240	.80
830	592	2034	.17	2255	.23	2426	.30	2592	.37	2742	.44	2864	.51	2969	.58	3065	.64	3159	.71	3250	.78	3342	.86
890	635	2181	.21	2392	.28	2556	.35	2710	.42	2860	.50	2989	.58	3096	.65	3193	.72	3283	.79	3370	.86	3456	.94
950	678	2328	.25	2529	.33	2687	.40	2832	.48	2977	.56	3110	.65	3223	.73	3320	.80	3410	.88	3495	.95	3577	1.03
1010	721	2475	.30	2668	.38	2821	.46	2958	.54	3094	.63	3227	.72	3345	.81	3447	.89	3538	.97	3622	1.05		
1070	764	2623	.36	2805	.45	2955	.53	3086	.61	3214	.70	3344	.80	3464	.89	3571	.98	3664	1.07				
1130	807	2770	.42	2946	.52	3090	.60	3217	.69	3338	.78	3461	.88	3581	.98	3691	1.08						
1190	850	2917	.49	3085	.59	3227	.69	3350	.78	3466	.87	3581	.97	3697	1.07								
1250	892	3064	.57	3224	.67	3364	.78	3484	.87	3596	.97	3705	1.07										
1310	935	3211	.66	3367	.77	3499	.87	3618	.97	3726	1.07												
1370	978	3358	.75	3509	.87	3638	.98	3754	1.08														
1430	1021	3505	.85	3651	.98	3776	1.09																

**80 TCNH-B**

CFM	OV	1.000" SP		1.250" SP		1.500" SP		1.750" SP		2.000" SP		2.250" SP		2.500" SP		2.750" SP		3.000" SP		3.500" SP		4.000" SP	
		RPM	BHP	RPM	BHP	RPM	BHP	RPM	BHP	RPM	BHP	RPM	BHP	RPM	BHP	RPM	BHP	RPM	BHP	RPM	BHP	RPM	BHP
425	303	1875	.15																				
485	346	1968	.18	2107	.22																		
545	389	2090	.21	2206	.25	2327	.29																
605	432	2214	.24	2328	.29	2432	.33	2538	.38	2656	.43												
665	475	2329	.28	2453	.33	2555	.38	2649	.43	2745	.48	2847	.53	2957	.60								
725	517	2434	.32	2570	.38	2680	.43	2773	.48	2861	.54	2948	.59	3036	.65	3132	.71	3236	.78				
785	560	2535	.36	2677	.43	2798	.49	2898	.55	2986	.60	3067	.66	3147	.72	3227	.78	3312	.84	3497	.98		
845	603	2640	.41	2779	.48	2907	.55	3017	.62	3110	.68	3193	.74	3270	.80	3345	.86	3419	.92	3573	1.05	3745	1.21
905	646	2749	.46	2882	.53	3010	.61	3126	.68	3228	.75	3317	.82	3395	.89	3468	.95	3539	1.01	3678	1.15	3822	1.29
965	689	2860	.51	2988	.59	3111	.67	3229	.75	3337	.83	3433	.91	3518	.98	3594	1.05	3665	1.12	3797	1.25	3927	1.40
1025	732	2974	.57	3097	.65	3215	.74	3331	.82	3441	.91	3543	.99	3634	1.08	3715	1.15	3789	1.23	3921	1.37	4046	1.52
1085	775	3089	.64	3209	.72	3323	.81	3434	.90	3543	.99	3646	1.08	3742	1.17	3829	1.26	3909	1.34	4047	1.50	4170	1.65
1145	817	3206	.71	3323	.80	3434	.89	3541	.98	3646	1.08	3747	1.17	3846	1.27	3937	1.36	4021	1.46	4169	1.63		
1205	860	3324	.79	3439	.88	3546	.97	3650	1.07	3751	1.17	3850	1.27	3947	1.37	4040	1.47	4128	1.57				
1265	903	3443	.88	3555	.97	3660	1.07	3762	1.17	3860	1.27	3955	1.37	4049	1.47	4141	1.58	4231	1.69				
1325	946	3564	.97	3672	1.07	3776	1.17	3875	1.27	3970	1.37	4063	1.48	4154	1.59								
1385	989	3685	1.07	3792	1.17	3893	1.27	3989	1.38	4082	1.49	4173	1.60										
1445	1032	3808	1.18	3912	1.28	4010	1.39	4105	1.50	4197	1.61												
1505	1075	3931	1.29	4032	1.40	4130	1.51	4223	1.63														
1565	1117	4056	1.42	4154	1.53																		

Performance certified is for installation type B: free inlet, ducted outlet. Power rating (BHP) does not include drive losses. Performance ratings do not include the effects of appurtenances (accessories).

## 100 TCN-B

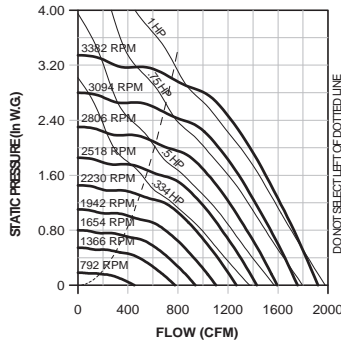

## 100 TCNH-B

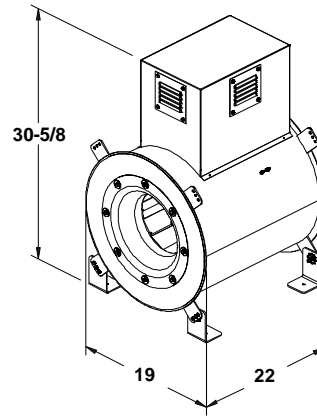
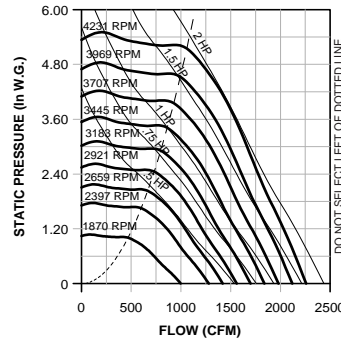

**Wheel Diameter = 10"**  
**Tip Speed (FPM) = 2.62 x RPM**  
**Max. BHP =**  
 TCN-B =  $0.028 \times (\text{RPM}/1000)^3$   
 TCNH-B =  $0.026 \times (\text{RPM}/1000)^3$   
**Outlet Area = 1.4 FT<sup>2</sup>**  
**Outlet Velocity (FPM) = CFM x 0.71**  
**Max. Motor Frame Size =**  
 TCN-B = 143T  
 TCNH-B = 145T  
**1140 RPM motor required**  
**on 1150 and lower FRPM**  
**3450 RPM motor required**  
**on 2700 and greater FRPM**

## 100 TCN-B

CFM	OV	0.000" SP		0.250" SP		0.500" SP		0.750" SP		1.000" SP		1.250" SP		1.500" SP		1.750" SP		2.000" SP		2.250" SP		2.500" SP	
		RPM	BHP	RPM	BHP	RPM	BHP	RPM	BHP	RPM	BHP	RPM	BHP	RPM	BHP	RPM	BHP	RPM	BHP	RPM	BHP	RPM	BHP
450	321	792	.01	1152	.04	1442	.08	1723	.13	1958	.18												
520	371	915	.02	1238	.05	1502	.10	1749	.15	1989	.21	2198	.26										
590	421	1039	.03	1332	.07	1576	.11	1796	.16	2015	.22	2227	.29	2417	.35	2587	.42						
660	471	1162	.04	1430	.08	1657	.13	1863	.18	2057	.24	2253	.31	2445	.39	2621	.46	2781	.53				
730	521	1285	.05	1532	.10	1744	.15	1938	.21	2119	.27	2294	.34	2471	.41	2646	.50	2812	.58	2964	.66	3105	.73
800	571	1408	.07	1636	.12	1836	.17	2019	.23	2191	.30	2354	.37	2513	.44	2675	.53	2836	.62	2991	.71	3137	.79
870	621	1532	.09	1742	.14	1933	.20	2105	.26	2269	.33	2424	.41	2573	.48	2719	.56	2867	.65	3016	.75	3162	.84
940	671	1655	.11	1851	.17	2032	.23	2196	.29	2351	.36	2500	.44	2642	.52	2779	.61	2914	.70	3051	.79	3189	.89
1010	721	1778	.13	1962	.20	2133	.26	2291	.33	2437	.40	2580	.48	2717	.57	2848	.66	2976	.75	3102	.84	3228	.94
1080	771	1901	.16	2074	.23	2237	.30	2388	.37	2528	.45	2663	.53	2795	.62	2922	.71	3045	.80	3164	.90	3282	1.00
1150	821	2025	.20	2187	.27	2342	.35	2487	.42	2623	.50	2752	.58	2878	.67	3000	.76	3119	.86	3234	.96	3346	1.06
1220	871	2148	.23	2302	.32	2448	.39	2588	.47	2719	.55	2844	.64	2964	.73	3081	.82	3197	.92	3308	1.03		
1290	921	2271	.28	2417	.36	2556	.45	2691	.53	2818	.61	2938	.70	3054	.79	3166	.89	3278	.99	3386	1.10		
1360	971	2394	.33	2534	.42	2665	.50	2795	.59	2918	.68	3035	.77	3146	.86	3255	.96	3362	1.06				
1430	1021	2518	.38	2652	.47	2777	.57	2901	.66	3020	.75	3133	.84	3242	.94	3346	1.04						
1500	1071	2641	.44	2768	.54	2888	.63	3007	.73	3122	.83	3233	.92	3339	1.02								
1570	1121	2764	.50	2886	.60	3002	.71	3115	.81	3227	.91	3334	1.01										
1640	1171	2887	.57	3006	.68	3114	.79	3225	.89	3332	1.00	3437	1.10										
1710	1221	3011	.65	3125	.76	3231	.87	3335	.99	3439	1.10												
1780	1271	3134	.73	3244	.85	3346	.97	3446	1.08														
1850	1321	3257	.82	3362	.94	3460	1.06																

## 100 TCNH-B

CFM	OV	1.000" SP		1.250" SP		1.500" SP		1.750" SP		2.000" SP		2.250" SP		2.500" SP		2.750" SP		3.000" SP		3.500" SP		4.000" SP	
		RPM	BHP	RPM	BHP	RPM	BHP	RPM	BHP	RPM	BHP	RPM	BHP	RPM	BHP	RPM	BHP	RPM	BHP	RPM	BHP	RPM	BHP
475	339	1870	.16																				
550	392	1929	.18	2103	.23																		
625	446	2000	.21	2165	.26	2321	.31	2472	.37														
700	500	2082	.24	2237	.29	2386	.35	2527	.41	2663	.47												
775	553	2176	.27	2319	.32	2459	.39	2595	.45	2725	.51	2850	.58	2972	.65	3093	.72						
850	607	2279	.31	2412	.37	2542	.43	2670	.49	2795	.56	2916	.63	3032	.71	3145	.78	3257	.86				
925	660	2389	.35	2512	.41	2634	.48	2754	.54	2871	.61	2988	.69	3100	.76	3209	.84	3316	.92	3522	1.09		
1000	714	2502	.40	2620	.46	2734	.53	2846	.60	2957	.67	3067	.75	3174	.83	3280	.91	3384	.99	3582	1.16	3773	1.34
1075	767	2619	.45	2732	.52	2840	.59	2946	.67	3050	.74	3153	.82	3255	.90	3357	.98	3457	1.07	3650	1.24	3835	1.43
1150	821	2736	.51	2847	.59	2951	.66	3051	.74	3151	.81	3248	.89	3345	.98	3441	1.06	3536	1.15	3722	1.33	3903	1.52
1225	875	2854	.57	2964	.65	3065	.73	3162	.81	3256	.89	3349	.98	3440	1.06	3531	1.15	3621	1.24	3800	1.43	3975	1.62
1300	928	2972	.64	3082	.73	3181	.81	3275	.90	3366	.98	3454	1.07	3542	1.16	3629	1.25	3715	1.34	3885	1.53	4052	1.73
1375	982	3089	.71	3200	.81	3298	.90	3391	.99	3479	1.08	3564	1.17	3647	1.26	3731	1.35	3813	1.44	3975	1.64	4136	1.84
1450	1035	3207	.79	3317	.89	3416	.99	3508	1.08	3594	1.18	3677	1.27	3758	1.37	3837	1.46	3916	1.56	4072	1.76	4225	1.97
1525	1089	3325	.88	3435	.98	3534	1.09	3626	1.19	3711	1.29	3792	1.39	3870	1.48	3947	1.58	4023	1.68	4173	1.89		
1600	1142	3444	.97	3552	1.08	3652	1.19	3744	1.30	3828	1.40	3908	1.51	3985	1.61	4060	1.71	4134	1.82				
1675	1196	3566	1.07	3670	1.18	3769	1.30	3861	1.41	3946	1.52	4025	1.63	4101	1.74	4175	1.85						
1750	1250	3688	1.17	3790	1.29	3887	1.41	3978	1.53	4064	1.65	4144	1.77	4219	1.88								
1825	1303	3813	1.29	3910	1.41	4005	1.54	4096	1.66	4182	1.79												
1900	1357	3937	1.41	4031	1.54	4124	1.67	4214	1.80														
1975	1410	4065	1.54	4154	1.67																		

Performance certified is for installation type B: free inlet, ducted outlet. Power rating (BHP) does not include drive losses. Performance ratings do not include the effects of appurtenances (accessories).

# 120 TCN-B/TCNH-B Data

**Wheel Diameter = 12"**  
**Tip Speed (FPM) = 3.14 x RPM**  
**Max. BHP =**  
 TCN-B =  $0.068 \times (\text{RPM}/1000)^3$   
 TCNH-B =  $0.063 \times (\text{RPM}/1000)^3$   
**Outlet Area = 1.77 FT<sup>2</sup>**  
**Outlet Velocity (FPM) = CFM x 0.56**  
**Max. Motor Frame Size =**  
 TCN-B = 145T  
 TCNH-B = 184T  
**1140 RPM motor required**  
**on 925 and lower FRPM**  
**3450 RPM motor required**  
**on 2700 and greater FRPM**

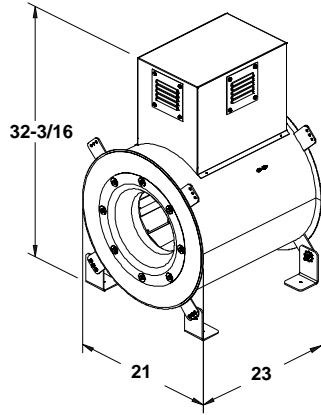

**120 TCN-B**

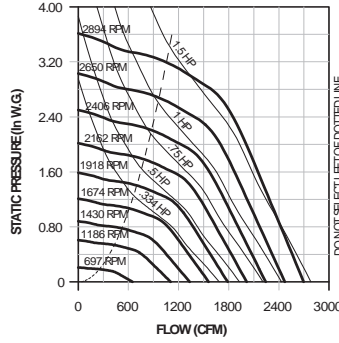

**120 TCNH-B**

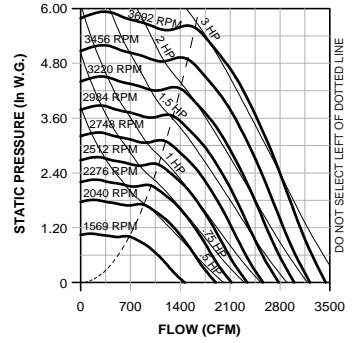

**120 TCN-B**

CFM	OV	0.000" SP		0.250" SP		0.500" SP		0.750" SP		1.000" SP		1.250" SP		1.500" SP		1.750" SP		2.000" SP		2.250" SP		2.500" SP	
		RPM	BHP	RPM	BHP	RPM	BHP	RPM	BHP	RPM	BHP	RPM	BHP	RPM	BHP	RPM	BHP	RPM	BHP	RPM	BHP	RPM	BHP
650	367	697	.02	974	.06	1215	.12	1441	.18	1634	.25												
750	424	805	.03	1057	.08	1259	.14	1473	.21	1664	.28	1833	.36	1990	.45								
850	481	912	.04	1144	.10	1325	.16	1508	.23	1696	.31	1864	.40	2016	.49	2159	.58						
950	537	1019	.06	1235	.12	1402	.18	1561	.26	1729	.34	1896	.44	2048	.53	2187	.63	2319	.73	2445	.84		
1050	594	1127	.08	1327	.15	1485	.22	1629	.29	1775	.38	1929	.48	2080	.58	2219	.68	2349	.79	2472	.90	2590	1.02
1150	650	1234	.11	1421	.18	1572	.26	1706	.33	1837	.42	1972	.52	2113	.63	2251	.74	2382	.85	2503	.97	2619	1.09
1250	707	1341	.14	1516	.22	1662	.30	1788	.38	1909	.46	2030	.57	2155	.68	2285	.79	2413	.91	2536	1.04	2651	1.16
1350	764	1448	.17	1613	.26	1752	.35	1875	.44	1988	.52	2099	.62	2212	.73	2328	.85	2448	.98	2568	1.11	2683	1.24
1450	820	1556	.21	1712	.30	1844	.40	1962	.50	2071	.59	2175	.68	2279	.80	2384	.92	2492	1.05	2603	1.18	2715	1.32
1550	877	1663	.26	1810	.36	1938	.46	2052	.57	2157	.66	2256	.76	2353	.87	2450	.99	2548	1.12	2649	1.26	2753	1.40
1650	933	1770	.31	1910	.42	2032	.53	2143	.64	2245	.75	2340	.85	2432	.95	2523	1.07	2614	1.20	2707	1.34	2801	1.49
1750	990	1878	.37	2010	.48	2127	.60	2235	.72	2334	.83	2426	.94	2515	1.05	2601	1.17	2687	1.30	2773	1.44	2860	1.58
1850	1046	1985	.44	2112	.56	2224	.68	2328	.81	2424	.93	2514	1.05	2599	1.16	2683	1.28	2764	1.40	2845	1.54		
1950	1103	2092	.52	2213	.64	2322	.77	2422	.90	2516	1.03	2604	1.16	2686	1.28	2767	1.40	2845	1.52				
2050	1160	2200	.60	2315	.73	2420	.86	2517	1.00	2608	1.14	2694	1.28	2775	1.41	2853	1.53						
2150	1216	2307	.69	2419	.83	2518	.96	2612	1.11	2701	1.26	2785	1.40	2865	1.54								
2250	1273	2414	.79	2522	.94	2618	1.08	2709	1.23	2795	1.38	2877	1.54										
2350	1329	2521	.90	2625	1.05	2718	1.20	2805	1.35	2890	1.51												
2450	1386	2629	1.02	2727	1.18	2817	1.33	2904	1.49														
2550	1443	2736	1.15	2831	1.31	2920	1.48	3002	1.64														
2650	1499	2843	1.29	2937	1.46	3021	1.63																

Reinforced wheel required on TCN-B for 2966 RPM or greater.

**120 TCNH-B**

CFM	OV	1.000" SP		1.250" SP		1.500" SP		1.750" SP		2.000" SP		2.250" SP		2.500" SP		2.750" SP		3.000" SP		3.500" SP		4.000" SP	
		RPM	BHP	RPM	BHP	RPM	BHP	RPM	BHP	RPM	BHP	RPM	BHP	RPM	BHP	RPM	BHP	RPM	BHP	RPM	BHP	RPM	BHP
700	396	1569	.22																				
825	466	1628	.26	1772	.33																		
950	537	1694	.30	1834	.37	1963	.45	2085	.53														
1075	608	1773	.35	1902	.43	2027	.51	2145	.59	2256	.68	2363	.77										
1200	679	1864	.41	1981	.49	2097	.57	2210	.66	2319	.75	2422	.85	2521	.95	2618	1.05						
1325	749	1963	.47	2072	.56	2178	.65	2283	.74	2386	.84	2487	.94	2584	1.04	2677	1.14	2767	1.26	2941	1.49		
1450	820	2066	.54	2169	.64	2268	.73	2365	.83	2461	.93	2557	1.04	2650	1.14	2742	1.25	2830	1.36	2998	1.60	3158	1.85
1575	891	2173	.63	2271	.73	2365	.83	2457	.93	2546	1.04	2635	1.15	2723	1.26	2810	1.37	2896	1.49	3061	1.73	3217	1.98
1700	962	2286	.72	2377	.82	2467	.93	2554	1.04	2639	1.15	2722	1.27	2804	1.38	2885	1.50	2967	1.62	3127	1.87	3281	2.13
1825	1032	2401	.83	2487	.93	2571	1.05	2655	1.16	2736	1.28	2816	1.40	2893	1.52	2970	1.65	3046	1.77	3198	2.03	3347	2.30
1950	1103	2519	.94	2601	1.06	2681	1.18	2760	1.30	2838	1.42	2914	1.55	2988	1.67	3061	1.80	3134	1.93	3277	2.20	3418	2.48
2075	1174	2639	1.07	2717	1.19	2793	1.32	2868	1.44	2942	1.57	3015	1.70	3087	1.84	3157	1.97	3226	2.11	3362	2.39	3496	2.67
2200	1245	2760	1.21	2836	1.34	2907	1.47	2979	1.60	3050	1.74	3120	1.87	3189	2.01	3257	2.15	3323	2.30	3454	2.59	3581	2.88
2325	1315	2884	1.37	2956	1.50	3025	1.64	3093	1.78	3161	1.92	3228	2.06	3294	2.20	3359	2.35	3423	2.50	3549	2.80	3672	3.11
2450	1386	3007	1.53	3077	1.68	3145	1.82	3210	1.97	3275	2.11	3338	2.26	3402	2.41	3464	2.56	3526	2.72	3649	3.03		
2575	1457	3131	1.72	3200	1.87	3265	2.02	3328	2.17	3390	2.32	3451	2.48	3512	2.63	3572	2.79	3632	2.95				
2700	1528	3255	1.91	3322	2.07	3386	2.23	3447	2.39	3507	2.55	3566	2.71	3625	2.87	3683	3.04						
2825	1598	3380	2.13	3447	2.30	3510	2.47	3569	2.63	3627	2.80	3684	2.96										
2950	1669	3505	2.36	3570	2.53	3632	2.71	3691	2.88														
3075	1740	3631	2.61																				

Performance certified is for installation type B: free inlet, ducted outlet. Power rating (BHP) does not include drive losses. Performance ratings do not include the effects of appurtenances (accessories). Shaded area indicates reinforced wheel required.



**135 TCN-B**

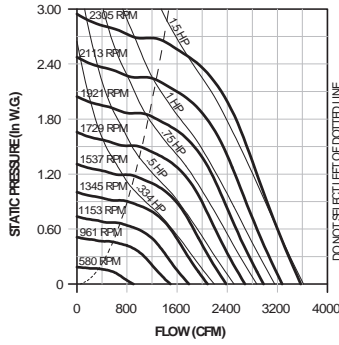

**135 TCNH-B**

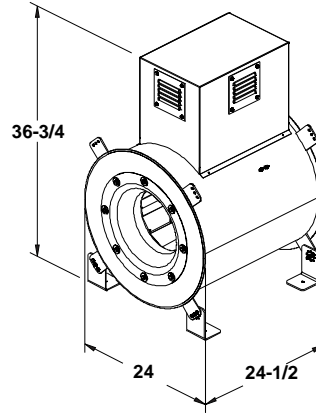
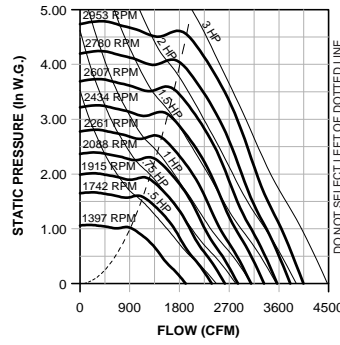

Wheel Diameter = 13.5"  
 Tip Speed (FPM) = 3.53 x RPM  
 Max. BHP =  
 TCN-B = 0.134 x (RPM/1000)<sup>3</sup>  
 TCNH-B = 0.108 x (RPM/1000)<sup>3</sup>  
 Outlet Area = 2.41 FT<sup>2</sup>  
 Outlet Velocity (FPM) = CFM x 0.41  
 Max. Motor Frame Size =  
 TCN-B = 145T  
 TCNH-B = 184T  
 1140 RPM motor required  
 on 825 and lower FRPM  
 3450 RPM motor required  
 on 2700 and greater FRPM

**135 TCN-B**

CFM	OV	0.000" SP		0.250" SP		0.500" SP		0.750" SP		1.000" SP		1.250" SP		1.500" SP		1.750" SP		2.000" SP		2.250" SP		2.500" SP	
		RPM	BHP	RPM	BHP	RPM	BHP	RPM	BHP	RPM	BHP	RPM	BHP	RPM	BHP	RPM	BHP	RPM	BHP	RPM	BHP	RPM	BHP
800	331	591	0.02	846	0.07	1059	0.14	1257	0.21	1433	0.29												
900	373	665	0.03	896	0.08	1093	0.15	1277	0.23	1447	0.32	1603	0.41										
1000	414	738	0.04	948	0.10	1135	0.17	1303	0.26	1466	0.34	1617	0.44	1758	0.54								
1100	456	812	0.05	1004	0.12	1181	0.19	1337	0.28	1489	0.38	1635	0.48	1772	0.58	1901	0.69	2024	0.80				
1200	497	886	0.07	1063	0.14	1230	0.22	1379	0.31	1519	0.41	1658	0.51	1790	0.62	1916	0.74	2036	0.86	2150	0.98		
1300	539	960	0.09	1124	0.16	1281	0.25	1424	0.34	1556	0.45	1685	0.55	1812	0.67	1935	0.79	2051	0.91	2163	1.04	2271	1.17
1400	580	1034	0.11	1187	0.19	1333	0.28	1472	0.38	1598	0.48	1719	0.60	1839	0.72	1956	0.84	2070	0.97	2180	1.10	2285	1.24
1500	622	1108	0.14	1251	0.22	1388	0.31	1522	0.41	1644	0.53	1759	0.65	1871	0.77	1983	0.90	2092	1.03	2199	1.16	2302	1.30
1600	663	1182	0.17	1317	0.25	1446	0.35	1573	0.45	1692	0.57	1803	0.70	1909	0.82	2014	0.96	2118	1.09	2222	1.23	2322	1.38
1700	705	1255	0.20	1383	0.29	1505	0.39	1625	0.50	1741	0.62	1849	0.75	1951	0.88	2051	1.02	2149	1.16	2248	1.31		
1800	746	1329	0.24	1450	0.33	1566	0.44	1680	0.55	1791	0.67	1897	0.81	1996	0.94	2092	1.09	2186	1.23	2279	1.38		
1900	788	1403	0.28	1519	0.38	1628	0.49	1736	0.60	1843	0.73	1946	0.87	2043	1.01	2136	1.16	2226	1.31	2315	1.46		
2000	829	1477	0.32	1587	0.43	1691	0.55	1795	0.66	1897	0.79	1996	0.93	2092	1.08	2182	1.23	2269	1.39				
2100	871	1551	0.37	1656	0.49	1756	0.61	1854	0.73	1952	0.86	2048	1.00	2141	1.15	2230	1.31	2315	1.47				
2200	912	1625	0.43	1725	0.55	1821	0.67	1915	0.80	2009	0.94	2101	1.08	2192	1.23	2279	1.39						
2300	954	1699	0.49	1795	0.62	1886	0.75	1977	0.88	2067	1.02	2155	1.16	2243	1.32	2328	1.48						
2400	995	1772	0.56	1866	0.69	1954	0.83	2040	0.96	2126	1.10	2211	1.25	2296	1.41								
2500	1037	1846	0.63	1936	0.77	2020	0.91	2104	1.05	2186	1.19	2268	1.34										
2600	1078	1920	0.71	2006	0.85	2088	1.00	2168	1.14	2248	1.29	2327	1.45										
2700	1120	1994	0.80	2078	0.94	2157	1.09	2234	1.25	2311	1.40												
2800	1161	2068	0.89	2150	1.04	2224	1.19	2299	1.35														
2900	1203	2142	0.99	2221	1.15	2294	1.31																
3000	1244	2215	1.09	2293	1.26																		

**135 TCNH-B**

CFM	OV	1.000" SP		1.250" SP		1.500" SP		1.750" SP		2.000" SP		2.250" SP		2.500" SP		2.750" SP		3.000" SP		3.500" SP		4.000" SP	
		RPM	BHP	RPM	BHP	RPM	BHP	RPM	BHP	RPM	BHP	RPM	BHP	RPM	BHP	RPM	BHP	RPM	BHP	RPM	BHP	RPM	BHP
950	394	1397	.28																				
1100	456	1450	.32	1574	.40																		
1250	518	1511	.37	1629	.46	1740	.55	1846	.64														
1400	580	1579	.43	1690	.52	1796	.61	1897	.71	1994	.82	2088	.93										
1550	643	1655	.49	1758	.59	1859	.69	1956	.79	2048	.90	2138	1.02	2224	1.13	2309	1.25						
1700	705	1738	.56	1832	.66	1927	.77	2019	.88	2108	1.00	2194	1.12	2278	1.24	2358	1.36	2437	1.49				
1850	767	1827	.64	1914	.75	2001	.87	2087	.98	2173	1.10	2256	1.23	2336	1.35	2415	1.48	2490	1.61	2637	1.89		
2000	829	1922	.74	2002	.85	2082	.97	2162	1.09	2243	1.22	2322	1.35	2399	1.48	2475	1.62	2549	1.75	2691	2.04	2827	2.34
2150	892	2017	.84	2094	.96	2168	1.08	2243	1.21	2317	1.34	2393	1.48	2467	1.62	2539	1.76	2610	1.90	2749	2.20	2881	2.50
2300	954	2113	.95	2189	1.08	2260	1.21	2328	1.34	2399	1.48	2468	1.62	2538	1.77	2608	1.92	2677	2.07	2810	2.37	2939	2.69
2450	1016	2208	1.07	2285	1.21	2354	1.35	2419	1.49	2484	1.63	2550	1.78	2616	1.93	2681	2.08	2747	2.24	2876	2.56		
2600	1078	2302	1.20	2381	1.36	2449	1.50	2513	1.65	2574	1.80	2636	1.95	2697	2.10	2759	2.26	2822	2.43	2945	2.76		
2750	1141	2394	1.33	2476	1.51	2545	1.67	2608	1.82	2668	1.98	2726	2.14	2784	2.30	2842	2.46	2900	2.63				
2900	1203	2487	1.48	2569	1.67	2641	1.84	2704	2.01	2763	2.17	2819	2.34	2874	2.50	2929	2.67						
3050	1265	2579	1.64	2662	1.84	2736	2.03	2800	2.21	2859	2.38	2914	2.56										
3200	1327	2671	1.81	2754	2.02	2829	2.22	2895	2.42														
3350	1390	2765	1.99	2846	2.21	2922	2.43																
3500	1452	2861	2.20	2938	2.42																		

Performance certified is for installation type B: free inlet, ducted outlet. Power rating (BHP) does not include drive losses. Performance ratings do not include the effects of appurtenances (accessories).



# 150 TCN-B/TCNH-B Data

**Wheel Diameter = 15"**  
**Tip Speed (FPM) = 3.93 x RPM**  
**Max. BHP =**  
 TCN-B =  $0.217 \times (\text{RPM}/1000)^3$   
 TCNH-B =  $0.198 \times (\text{RPM}/1000)^3$   
**Outlet Area = 3.14 FT<sup>2</sup>**  
**Outlet Velocity (FPM) = CFM x 0.32**  
**Max. Motor Frame Size =**  
 TCN-B = 145T  
 TCNH-B = 184T  
**1140 RPM motor required**  
**on 650 and lower FRPM**

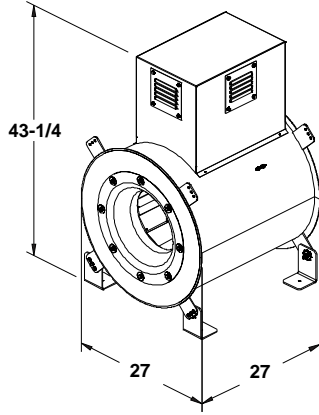

**150 TCN-B**

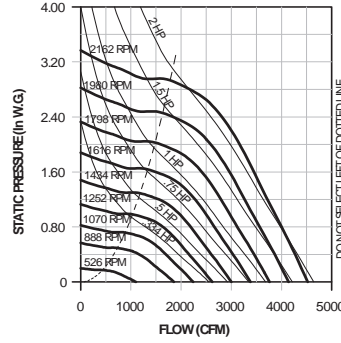

**150 TCNH-B**

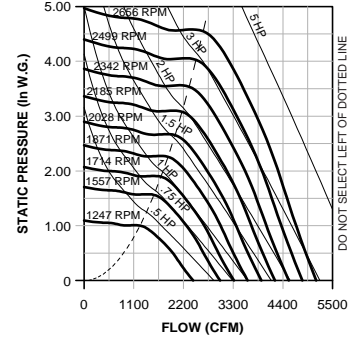

**150 TCN-B**

CFM	OV	0.000" SP		0.250" SP		0.500" SP		0.750" SP		1.000" SP		1.250" SP		1.500" SP		1.750" SP		2.000" SP		2.250" SP		2.500" SP	
		RPM	BHP	RPM	BHP	RPM	BHP	RPM	BHP	RPM	BHP	RPM	BHP	RPM	BHP	RPM	BHP	RPM	BHP	RPM	BHP	RPM	BHP
1100	350	526	.03	757	.09	942	.18	1116	.27	1268	.38												
1270	404	607	.04	819	.12	983	.21	1140	.31	1288	.42	1422	.54										
1440	458	688	.06	884	.15	1033	.24	1174	.35	1312	.47	1443	.60	1564	.73	1676	.87						
1610	512	770	.08	951	.18	1090	.28	1219	.39	1344	.52	1467	.65	1585	.80	1696	.95	1800	1.10	1899	1.26		
1780	566	851	.11	1020	.22	1152	.33	1271	.44	1386	.57	1498	.71	1609	.86	1717	1.02	1820	1.18	1917	1.35	2010	1.53
1950	621	932	.15	1089	.26	1216	.38	1328	.51	1434	.64	1538	.78	1641	.94	1743	1.10	1842	1.27	1938	1.45	2030	1.63
2120	675	1013	.19	1160	.31	1283	.44	1388	.57	1488	.71	1586	.86	1681	1.02	1776	1.19	1869	1.37	1961	1.55	2051	1.74
2290	729	1095	.24	1231	.37	1351	.51	1452	.65	1546	.80	1638	.95	1727	1.12	1816	1.29	1904	1.47	1990	1.66	2076	1.85
2460	783	1176	.30	1304	.44	1419	.59	1518	.74	1608	.89	1694	1.05	1779	1.22	1862	1.40	1944	1.58	2026	1.78	2107	1.98
2630	837	1257	.36	1378	.52	1488	.67	1585	.84	1671	.99	1754	1.16	1834	1.33	1913	1.52	1991	1.71	2068	1.91	2144	2.11
2800	891	1338	.44	1452	.60	1558	.77	1652	.94	1737	1.11	1816	1.28	1892	1.46	1967	1.65	2041	1.84	2114	2.05		
2970	945	1420	.52	1527	.69	1628	.87	1721	1.05	1803	1.23	1880	1.41	1953	1.60	2025	1.79	2095	1.99	2165	2.20		
3140	999	1501	.62	1604	.80	1699	.98	1790	1.18	1871	1.37	1945	1.56	2016	1.75	2085	1.95	2152	2.15				
3310	1054	1582	.72	1680	.91	1772	1.11	1859	1.31	1939	1.51	2012	1.71	2081	1.91	2147	2.12						
3480	1108	1663	.84	1757	1.04	1844	1.24	1929	1.46	2007	1.67	2079	1.88	2147	2.09								
3650	1162	1745	.97	1835	1.18	1918	1.39	2000	1.61	2076	1.84	2147	2.06										
3820	1216	1826	1.11	1912	1.33	1992	1.55	2070	1.78	2145	2.02												
3990	1270	1907	1.27	1989	1.49	2067	1.73	2143	1.97														
4160	1324	1989	1.44	2068	1.68	2142	1.91	2215	2.16														
4330	1378	2070	1.62	2147	1.87	2218	2.12																
4500	1433	2151	1.82	2226	2.08																		

Shaded area indicates reinforced wheel required. Reinforced wheel required on TCN-B for 2116 RPM or greater.

**150 TCNH-B**

CFM	OV	1.000" SP		1.250" SP		1.500" SP		1.750" SP		2.000" SP		2.250" SP		2.500" SP		2.750" SP		3.000" SP		3.500" SP		4.000" SP	
		RPM	BHP	RPM	BHP	RPM	BHP	RPM	BHP	RPM	BHP	RPM	BHP	RPM	BHP	RPM	BHP	RPM	BHP	RPM	BHP	RPM	BHP
1250	398	1247	.36																				
1425	453	1278	.40	1397	.51																		
1600	509	1327	.46	1431	.57	1536	.69																
1775	565	1383	.52	1479	.64	1573	.76	1667	.88	1764	1.02												
1950	621	1442	.59	1534	.72	1622	.84	1708	.97	1793	1.11	1880	1.26										
2125	676	1505	.67	1593	.80	1677	.93	1758	1.07	1836	1.21	1914	1.36	1993	1.51	2074	1.68						
2300	732	1570	.76	1655	.89	1736	1.04	1813	1.18	1888	1.33	1961	1.48	2033	1.64	2105	1.80	2178	1.97				
2475	788	1639	.85	1719	1.00	1797	1.15	1872	1.30	1943	1.45	2013	1.61	2081	1.77	2149	1.94	2216	2.11	2351	2.47		
2650	843	1710	.96	1785	1.11	1860	1.27	1933	1.43	2002	1.59	2070	1.76	2135	1.93	2199	2.10	2262	2.27	2388	2.64	2514	3.02
2825	899	1784	1.08	1855	1.24	1926	1.40	1996	1.57	2063	1.74	2129	1.91	2192	2.09	2254	2.27	2314	2.45	2433	2.82	2550	3.21
3000	955	1861	1.20	1927	1.37	1994	1.54	2060	1.71	2126	1.89	2190	2.08	2251	2.26	2311	2.45	2370	2.64	2484	3.02	2596	3.42
3175	1011	1940	1.34	2002	1.52	2065	1.70	2128	1.88	2191	2.06	2253	2.25	2313	2.44	2371	2.64	2428	2.84	2539	3.24	2646	3.65
3350	1066	2021	1.50	2079	1.68	2139	1.87	2198	2.05	2258	2.25	2317	2.44	2376	2.64	2433	2.84	2488	3.05	2596	3.47		
3525	1122	2102	1.66	2158	1.85	2214	2.05	2270	2.24	2327	2.44	2384	2.65	2440	2.85	2496	3.06	2550	3.27	2655	3.71		
3700	1178	2184	1.84	2238	2.04	2291	2.24	2345	2.45	2399	2.66	2453	2.87	2507	3.08	2561	3.30	2613	3.51				
3875	1234	2266	2.04	2319	2.24	2370	2.45	2421	2.67	2473	2.88	2524	3.10	2576	3.32	2627	3.54						
4050	1289	2349	2.25	2401	2.46	2451	2.68	2499	2.90	2547	3.12	2597	3.35	2646	3.58								
4225	1345	2432	2.47	2483	2.70	2532	2.93	2578	3.15	2624	3.38												
4400	1401	2517	2.72	2565	2.94	2613	3.18																

Performance certified is for installation type B: free inlet, ducted outlet. Power rating (BHP) does not include drive losses. Performance ratings do not include the effects of appurtenances (accessories).

## 165 TCN-B

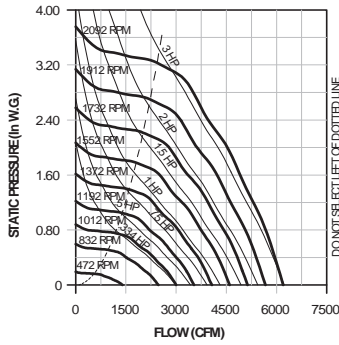

## 165 TCNH-B

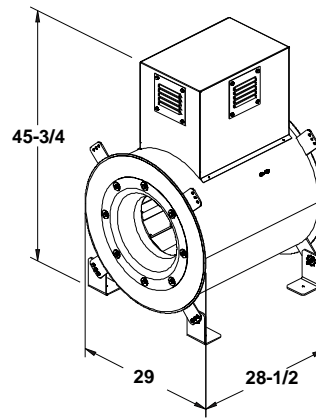
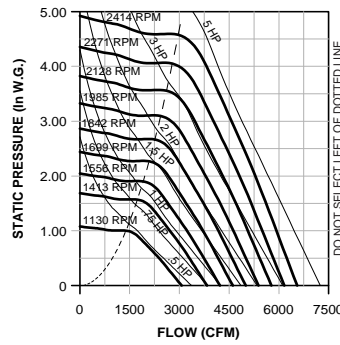

**Wheel Diameter = 16.5"**  
**Tip Speed (FPM) = 3.93 x RPM**  
**Max. BHP =**  
 TCN-B =  $0.360 \times (\text{RPM}/1000)^3$   
 TCNH-B =  $0.321 \times (\text{RPM}/1000)^3$   
**Outlet Area = 3.69 FT<sup>2</sup>**  
**Outlet Velocity (FPM) = CFM x 0.27**  
**Max. Motor Frame Size =**  
 TCN-B = 182T  
 TCNH-B = 184T  
**1140 RPM motor required on 650 and lower FRPM**

## 165 TCN-B

CFM	OV	0.000" SP		0.250" SP		0.500" SP		0.750" SP		1.000" SP		1.250" SP		1.500" SP		1.750" SP		2.000" SP		2.250" SP		2.500" SP	
		RPM	BHP	RPM	BHP	RPM	BHP	RPM	BHP	RPM	BHP	RPM	BHP	RPM	BHP	RPM	BHP	RPM	BHP	RPM	BHP	RPM	BHP
1400	379	472	.03	698	.12	867	.23	1025	.35	1167	.49												
1630	442	550	.05	746	.15	916	.27	1048	.40	1185	.55	1310	.70										
1860	504	627	.08	805	.19	965	.32	1092	.46	1207	.61	1328	.78	1441	.95	1545	1.13						
2090	566	705	.11	867	.23	1009	.37	1143	.52	1248	.69	1351	.86	1459	1.04	1563	1.23	1659	1.43	1750	1.64		
2320	629	783	.16	928	.28	1059	.43	1190	.59	1299	.77	1392	.95	1485	1.14	1581	1.34	1677	1.55	1768	1.77	1854	1.99
2550	691	860	.21	990	.34	1117	.50	1234	.67	1349	.86	1443	1.06	1527	1.25	1611	1.46	1698	1.68	1786	1.91	1872	2.14
2780	754	938	.27	1054	.41	1179	.59	1283	.76	1393	.96	1494	1.17	1577	1.38	1655	1.60	1731	1.82	1810	2.05	1890	2.29
3010	816	1015	.34	1120	.49	1240	.68	1339	.86	1437	1.06	1540	1.29	1629	1.52	1706	1.75	1777	1.98	1847	2.22	1919	2.46
3240	878	1093	.42	1190	.58	1301	.78	1400	.98	1488	1.18	1582	1.41	1676	1.66	1757	1.91	1828	2.15	1895	2.40	1960	2.65
3470	941	1171	.52	1261	.69	1362	.89	1461	1.11	1545	1.32	1629	1.55	1719	1.80	1804	2.07	1880	2.33	1947	2.60	2010	2.86
3700	1003	1248	.63	1332	.81	1425	1.02	1522	1.25	1605	1.48	1683	1.71	1763	1.96	1847	2.23	1927	2.52	1998	2.80	2062	3.08
3930	1065	1326	.75	1405	.94	1490	1.16	1583	1.41	1666	1.65	1741	1.89	1814	2.14	1891	2.42	1970	2.71	2045	3.01		
4160	1128	1403	.89	1479	1.10	1556	1.31	1645	1.57	1728	1.84	1801	2.09	1870	2.35	1940	2.62	2014	2.92	2088	3.22		
4390	1190	1481	1.05	1552	1.26	1625	1.49	1707	1.75	1789	2.03	1862	2.30	1929	2.57	1994	2.85	2061	3.14				
4620	1253	1559	1.23	1627	1.45	1694	1.68	1770	1.95	1850	2.24	1924	2.54	1989	2.82	2052	3.10						
4850	1315	1636	1.42	1702	1.65	1765	1.89	1835	2.16	1911	2.47	1985	2.78	2051	3.08								
5080	1377	1714	1.63	1776	1.87	1837	2.12	1902	2.40	1974	2.71	2046	3.04										
5310	1440	1791	1.86	1850	2.11	1908	2.37	1969	2.65	2036	2.97												
5540	1502	1869	2.11	1926	2.38	1982	2.65	2039	2.93	2102	3.25												
5770	1564	1947	2.39	2003	2.67	2055	2.94	2108	3.23														
6000	1627	2024	2.68	2080	2.98	2128	3.26																

Shaded area indicates reinforced wheel required. Reinforced wheel required on TCN-B for 1833 RPM or greater.

## 165 TCNH-B

CFM	OV	1.000" SP		1.250" SP		1.500" SP		1.750" SP		2.000" SP		2.250" SP		2.500" SP		2.750" SP		3.000" SP		3.500" SP		4.000" SP	
		RPM	BHP	RPM	BHP	RPM	BHP	RPM	BHP	RPM	BHP	RPM	BHP	RPM	BHP	RPM	BHP	RPM	BHP	RPM	BHP	RPM	BHP
1425	386	1130	.43																				
1650	447	1154	.48	1268	.61																		
1875	508	1199	.55	1296	.68	1395	.83	1495	.99														
2100	569	1254	.63	1342	.76	1427	.91	1515	1.07	1604	1.24	1694	1.43										
2325	630	1311	.73	1396	.87	1475	1.02	1553	1.17	1631	1.34	1711	1.53	1792	1.73	1873	1.93						
2550	691	1370	.83	1453	.99	1530	1.15	1603	1.31	1673	1.47	1744	1.65	1817	1.85	1890	2.06	1963	2.27				
2775	752	1430	.94	1511	1.11	1587	1.29	1658	1.46	1725	1.63	1790	1.81	1855	2.00	1921	2.20	1987	2.42	2122	2.88		
3000	813	1491	1.06	1571	1.25	1645	1.43	1715	1.62	1780	1.81	1843	2.00	1904	2.19	1964	2.38	2025	2.60	2147	3.05	2272	3.54
3225	874	1555	1.19	1632	1.39	1704	1.59	1773	1.80	1838	2.00	1899	2.20	1958	2.40	2016	2.60	2072	2.81	2184	3.25	2298	3.74
3450	935	1620	1.34	1694	1.55	1765	1.76	1832	1.98	1896	2.20	1957	2.41	2015	2.63	2071	2.84	2125	3.06	2230	3.50	2335	3.98
3675	996	1687	1.50	1758	1.72	1827	1.95	1893	2.18	1955	2.40	2015	2.64	2072	2.86	2127	3.09	2181	3.33	2283	3.79	2381	4.26
3900	1057	1756	1.67	1824	1.90	1890	2.14	1954	2.38	2015	2.63	2074	2.87	2131	3.12	2185	3.36	2238	3.61	2338	4.09		
4125	1118	1826	1.86	1891	2.11	1955	2.36	2017	2.61	2077	2.87	2134	3.12	2190	3.38	2244	3.64	2296	3.90	2395	4.41		
4350	1179	1897	2.07	1960	2.33	2021	2.59	2081	2.85	2139	3.12	2196	3.39	2250	3.66	2303	3.93	2354	4.20				
4575	1240	1968	2.30	2030	2.57	2089	2.83	2147	3.11	2203	3.39	2258	3.67	2312	3.95	2364	4.24	2414	4.52				
4800	1301	2041	2.54	2101	2.82	2157	3.10	2214	3.39	2268	3.67	2322	3.97	2374	4.27								
5025	1362	2115	2.81	2172	3.10	2228	3.39	2282	3.69	2335	3.99	2387	4.29										
5250	1423	2189	3.09	2245	3.39	2298	3.69	2351	4.00	2402	4.31												
5475	1484	2264	3.40	2317	3.71	2370	4.02																
5700	1545	2339	3.72	2392	4.05																		

Performance certified is for installation type B: free inlet, ducted outlet. Power rating (BHP) does not include drive losses. Performance ratings do not include the effects of appurtenances (accessories).

# 180 TCN-B/TCNH-B Data

**Wheel Diameter = 18"**  
**Tip Speed (FPM) = 4.71 x RPM**  
**Max. BHP =**  
 TCN-B =  $0.549 \times (\text{RPM}/1000)^3$   
 TCNH-B =  $0.467 \times (\text{RPM}/1000)^3$   
**Outlet Area = 4.27 FT<sup>2</sup>**  
**Outlet Velocity (FPM) = CFM x 0.23**  
**Max. Motor Frame Size =**  
 TCN-B = 182T  
 TCNH-B = 213T

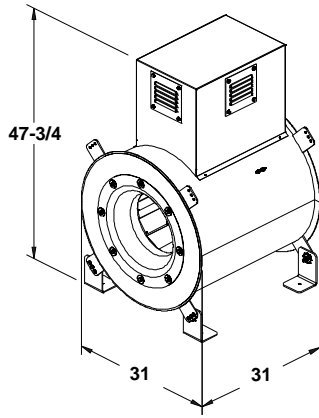

**180 TCN-B**

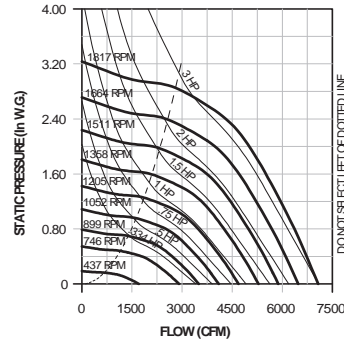

**180 TCNH-B**

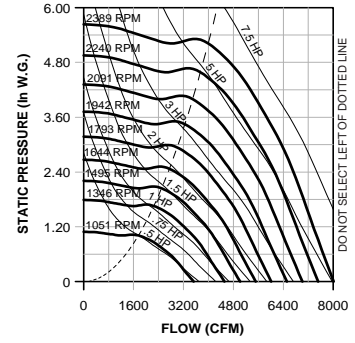

**180 TCN-B**

CFM	OV	0.000" SP		0.250" SP		0.500" SP		0.750" SP		1.000" SP		1.250" SP		1.500" SP		1.750" SP		2.000" SP		2.250" SP		2.500" SP	
		RPM	BHP	RPM	BHP	RPM	BHP	RPM	BHP	RPM	BHP	RPM	BHP	RPM	BHP	RPM	BHP	RPM	BHP	RPM	BHP	RPM	BHP
1700	398	437	.04	630	.14	802	.27	950	.42	1078	.57												
1960	459	503	.06	676	.17	828	.31	972	.48	1097	.65	1210	.82										
2220	519	570	.09	727	.21	862	.35	996	.53	1118	.72	1229	.92	1330	1.11	1425	1.31						
2480	580	637	.13	780	.26	904	.41	1024	.58	1142	.79	1250	1.01	1350	1.23	1443	1.45	1530	1.66				
2740	641	704	.17	835	.32	951	.47	1059	.65	1168	.86	1273	1.09	1371	1.33	1463	1.58	1549	1.82	1630	2.06	1708	2.30
3000	702	771	.23	891	.38	1000	.55	1101	.73	1200	.94	1299	1.18	1395	1.43	1485	1.70	1570	1.97	1650	2.23	1727	2.50
3260	763	837	.29	948	.46	1052	.64	1146	.83	1238	1.04	1329	1.28	1420	1.54	1508	1.81	1592	2.10	1671	2.39	1747	2.68
3520	824	904	.37	1007	.55	1106	.74	1195	.94	1281	1.15	1365	1.40	1450	1.66	1534	1.94	1616	2.24	1694	2.54	1769	2.85
3780	885	971	.46	1068	.65	1160	.85	1246	1.06	1327	1.28	1406	1.53	1484	1.79	1563	2.08	1641	2.38	1718	2.69	1792	3.02
4040	946	1038	.56	1128	.76	1216	.98	1298	1.20	1375	1.43	1450	1.67	1524	1.94	1597	2.23	1671	2.54	1744	2.86	1816	3.19
4300	1007	1105	.67	1190	.89	1272	1.12	1352	1.35	1426	1.59	1497	1.84	1567	2.11	1636	2.40	1705	2.71	1774	3.04		
4560	1067	1171	.80	1253	1.04	1330	1.27	1406	1.52	1478	1.77	1546	2.03	1612	2.30	1678	2.60	1743	2.91	1808	3.23		
4820	1128	1238	.94	1315	1.19	1389	1.45	1461	1.70	1531	1.96	1597	2.23	1660	2.51	1723	2.81	1785	3.12				
5080	1189	1305	1.10	1378	1.37	1448	1.63	1518	1.90	1585	2.18	1649	2.46	1710	2.74	1770	3.04						
5340	1250	1372	1.28	1442	1.56	1509	1.84	1575	2.12	1639	2.40	1701	2.69	1761	2.99	1819	3.30						
5600	1311	1438	1.48	1505	1.77	1569	2.06	1632	2.36	1694	2.65	1755	2.96	1813	3.26								
5860	1372	1505	1.69	1569	2.00	1631	2.31	1691	2.61	1751	2.92	1809	3.23										
6120	1433	1572	1.93	1634	2.25	1692	2.57	1750	2.89	1808	3.21												
6380	1494	1639	2.19	1699	2.52	1755	2.85	1811	3.19														
6640	1555	1706	2.47	1764	2.82	1817	3.16																
6900	1615	1772	2.77	1828	3.13																		

Shaded area indicates reinforced wheel required. Reinforced wheel required on TCN-B for 1610 RPM or greater.

**180 TCNH-B**

CFM	OV	1.000" SP		1.250" SP		1.500" SP		1.750" SP		2.000" SP		2.250" SP		2.500" SP		2.750" SP		3.000" SP		3.500" SP		4.000" SP	
		RPM	BHP	RPM	BHP	RPM	BHP	RPM	BHP	RPM	BHP	RPM	BHP	RPM	BHP	RPM	BHP	RPM	BHP	RPM	BHP	RPM	BHP
1800	421	1051	.50																				
2100	491	1085	.58	1184	.73																		
2400	562	1129	.67	1220	.83	1308	.99	1392	1.17														
2700	632	1182	.77	1265	.95	1347	1.12	1426	1.30	1502	1.49	1576	1.69										
3000	702	1241	.89	1319	1.08	1393	1.26	1466	1.45	1539	1.65	1609	1.86	1678	2.07	1744	2.29						
3300	772	1301	1.01	1377	1.22	1447	1.42	1515	1.63	1582	1.84	1648	2.05	1713	2.27	1777	2.50	1839	2.73	1960	3.23		
3600	843	1365	1.16	1437	1.37	1505	1.59	1570	1.81	1632	2.04	1694	2.27	1755	2.50	1815	2.73	1875	2.97	1991	3.48	2102	4.01
3900	913	1434	1.33	1499	1.54	1565	1.77	1628	2.01	1688	2.25	1746	2.50	1803	2.74	1860	2.99	1916	3.24	2027	3.76	2134	4.30
4200	983	1507	1.52	1566	1.74	1627	1.97	1688	2.23	1747	2.49	1802	2.74	1857	3.00	1910	3.27	1963	3.53	2067	4.07	2171	4.63
4500	1053	1582	1.74	1636	1.96	1693	2.20	1750	2.46	1806	2.73	1861	3.00	1914	3.28	1965	3.56	2015	3.84	2114	4.41	2212	4.99
4800	1124	1660	2.00	1710	2.22	1762	2.46	1814	2.71	1868	2.99	1921	3.28	1973	3.57	2023	3.87	2072	4.17	2166	4.77	2258	5.37
5100	1194	1740	2.28	1787	2.51	1834	2.75	1883	3.01	1933	3.29	1984	3.58	2034	3.89	2083	4.20	2130	4.51	2222	5.14	2310	5.78
5400	1264	1820	2.58	1865	2.83	1910	3.08	1955	3.34	2000	3.61	2048	3.91	2096	4.22	2143	4.54	2190	4.87	2280	5.54	2365	6.21
5700	1334	1901	2.92	1944	3.18	1987	3.44	2029	3.70	2072	3.98	2115	4.27	2160	4.59	2206	4.92	2251	5.26	2339	5.95		
6000	1405	1983	3.29	2025	3.56	2065	3.83	2105	4.10	2145	4.39	2186	4.68	2228	5.00	2271	5.33	2313	5.67				
6300	1475	2065	3.69	2105	3.97	2145	4.26	2183	4.54	2221	4.83	2260	5.14	2299	5.45	2338	5.77	2379	6.12				
6600	1545	2148	4.12	2188	4.43	2226	4.73	2263	5.03	2299	5.32	2336	5.63	2372	5.95								
6900	1615	2230	4.58	2269	4.90	2306	5.22	2342	5.53	2377	5.84												
7200	1686	2315	5.09	2352	5.43	2388	5.76																

Performance certified is for installation type B: free inlet, ducted outlet. Power rating (BHP) does not include drive losses. Performance ratings do not include the effects of appurtenances (accessories).

## 195 TCN-B

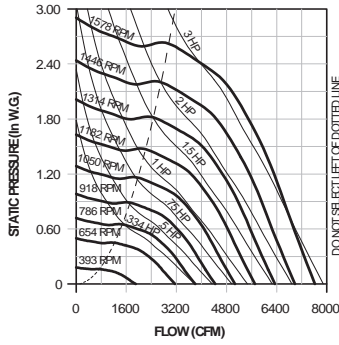

## 195 TCNH-B

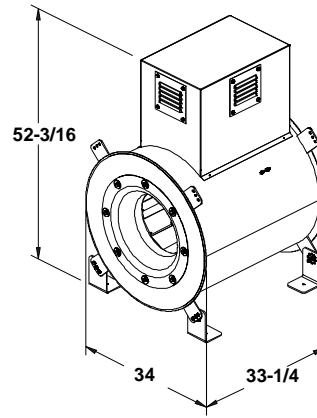
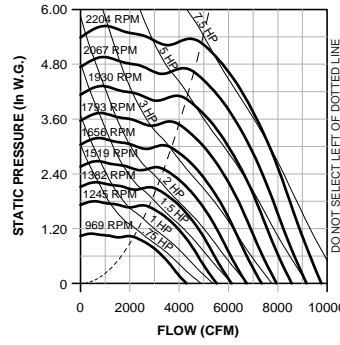

**Wheel Diameter = 19.5"**  
**Tip Speed (FPM) = 5.11 x RPM**  
**Max. BHP =**  
 TCN-B =  $0.839 \times (\text{RPM}/1000)^3$   
 TCNH-B =  $0.728 \times (\text{RPM}/1000)^3$   
**Outlet Area = 5.24 FT<sup>2</sup>**  
**Outlet Velocity (FPM) = CFM x 0.19**  
**Max. Motor Frame Size =**  
 TCN-B = 182T  
 TCNH-B = 213T

## 195 TCN-B

CFM	OV	0.000" SP		0.250" SP		0.500" SP		0.750" SP		1.000" SP		1.250" SP		1.500" SP		1.750" SP		2.000" SP		2.250" SP		2.500" SP		
		RPM	BHP	RPM	BHP	RPM	BHP	RPM	BHP	RPM	BHP	RPM	BHP	RPM	BHP	RPM	BHP	RPM	BHP	RPM	BHP	RPM	BHP	RPM
1900	362	393	.04	568	.15	724	.29	861	.46	978	.64													
2180	416	451	.06	607	.19	745	.33	878	.52	993	.71	1096	.91											
2460	469	509	.09	649	.23	774	.38	896	.57	1010	.78	1111	1.00	1204	1.22									
2740	522	567	.13	695	.27	810	.44	918	.63	1028	.85	1129	1.09	1220	1.33	1305	1.58	1385	1.83					
3020	576	625	.17	745	.33	849	.51	948	.70	1048	.92	1147	1.17	1238	1.44	1322	1.71	1400	1.98	1475	2.25	1546	2.52	
3300	629	683	.22	795	.39	890	.59	984	.80	1074	1.01	1166	1.26	1255	1.53	1339	1.82	1417	2.12	1491	2.42	1561	2.71	
3580	683	741	.28	847	.47	935	.67	1023	.90	1107	1.13	1190	1.37	1274	1.64	1357	1.94	1435	2.25	1508	2.57	1578	2.89	
3860	736	799	.35	900	.56	981	.77	1063	1.00	1143	1.25	1220	1.50	1297	1.77	1376	2.07	1453	2.39	1526	2.72	1595	3.06	
4140	790	857	.43	953	.66	1030	.88	1106	1.12	1182	1.39	1255	1.65	1326	1.92	1399	2.21	1472	2.53	1544	2.88	1613	3.23	
4420	843	915	.53	1006	.77	1080	1.00	1150	1.25	1222	1.53	1292	1.81	1360	2.09	1427	2.38	1495	2.70	1563	3.04			
4700	896	973	.63	1060	.89	1131	1.14	1197	1.39	1264	1.68	1332	1.98	1396	2.28	1460	2.58	1523	2.89	1586	3.22			
4980	950	1031	.76	1114	1.03	1183	1.29	1245	1.55	1308	1.84	1372	2.16	1435	2.48	1495	2.79	1555	3.11					
5260	1003	1089	.89	1168	1.17	1235	1.45	1295	1.73	1354	2.03	1414	2.35	1474	2.68	1533	3.02							
5540	1057	1147	1.04	1224	1.34	1288	1.64	1346	1.93	1401	2.23	1458	2.56	1516	2.91	1572	3.26							
5820	1110	1205	1.21	1279	1.53	1341	1.83	1397	2.14	1450	2.45	1504	2.78	1558	3.14									
6100	1164	1263	1.39	1333	1.72	1395	2.05	1448	2.36	1500	2.69	1550	3.02											
6380	1217	1321	1.59	1389	1.94	1448	2.28	1501	2.61	1551	2.95	1599	3.29											
6660	1270	1379	1.81	1445	2.18	1502	2.53	1554	2.88	1602	3.23													
6940	1324	1437	2.04	1501	2.43	1556	2.80	1606	3.16															
7220	1377	1495	2.30	1556	2.70	1610	3.09																	
7500	1431	1553	2.58	1612	2.99																			

Shaded area indicates reinforced wheel required. Reinforced wheel required on TCN-B for 1429 RPM or greater.

## 195 TCNH-B

CFM	OV	1.000" SP		1.250" SP		1.500" SP		1.750" SP		2.000" SP		2.250" SP		2.500" SP		2.750" SP		3.000" SP		3.500" SP		4.000" SP	
		RPM	BHP	RPM	BHP	RPM	BHP	RPM	BHP	RPM	BHP	RPM	BHP	RPM	BHP	RPM	BHP	RPM	BHP	RPM	BHP	RPM	BHP
2250	429	969	.62																				
2600	496	1003	.72	1091	.90																		
2950	562	1043	.83	1126	1.02	1205	1.22	1280	1.43														
3300	629	1091	.94	1167	1.16	1241	1.38	1312	1.60	1381	1.82	1448	2.05										
3650	696	1143	1.07	1214	1.30	1283	1.54	1350	1.78	1415	2.02	1479	2.27	1541	2.52	1601	2.78						
4000	763	1200	1.23	1266	1.46	1330	1.71	1393	1.97	1454	2.23	1515	2.50	1574	2.77	1632	3.04	1688	3.32				
4350	830	1260	1.40	1321	1.64	1381	1.90	1441	2.18	1499	2.46	1556	2.74	1612	3.03	1667	3.32	1721	3.61	1826	4.21		
4700	896	1323	1.60	1380	1.85	1437	2.12	1492	2.40	1547	2.69	1601	2.99	1654	3.30	1707	3.61	1758	3.92	1859	4.55	1956	5.19
5050	963	1388	1.82	1442	2.09	1495	2.36	1548	2.65	1599	2.95	1651	3.27	1701	3.58	1751	3.91	1800	4.25	1896	4.91	1990	5.59
5400	1030	1456	2.08	1506	2.35	1556	2.63	1605	2.93	1655	3.24	1703	3.56	1751	3.89	1798	4.23	1845	4.58	1937	5.29	2027	6.00
5750	1097	1526	2.36	1573	2.65	1619	2.93	1666	3.24	1712	3.55	1759	3.89	1804	4.22	1850	4.58	1894	4.94	1982	5.68	2068	6.43
6100	1164	1597	2.68	1641	2.97	1685	3.27	1729	3.58	1772	3.90	1816	4.24	1860	4.59	1903	4.95	1946	5.32	2030	6.09	2113	6.88
6450	1230	1668	3.02	1710	3.32	1752	3.64	1794	3.96	1835	4.29	1876	4.63	1918	4.99	1959	5.36	2000	5.74	2081	6.52	2160	7.34
6800	1297	1740	3.39	1781	3.72	1821	4.04	1860	4.37	1899	4.71	1939	5.07	1978	5.43	2017	5.80	2057	6.19	2134	6.99		
7150	1364	1813	3.81	1852	4.14	1890	4.48	1928	4.82	1965	5.17	2003	5.54	2040	5.91	2078	6.29	2115	6.68	2190	7.50		
7500	1431	1885	4.24	1924	4.60	1962	4.96	1998	5.32	2033	5.68	2069	6.05	2104	6.43	2140	6.82	2176	7.22				
7850	1498	1959	4.73	1997	5.10	2033	5.47	2068	5.85	2102	6.22	2136	6.60	2170	6.99	2204	7.39						
8200	1564	2032	5.24	2070	5.64	2105	6.03	2139	6.42	2171	6.79												
8550	1631	2106	5.79	2142	6.20	2177	6.62																

Performance certified is for installation type B: free inlet, ducted outlet. Power rating (BHP) does not include drive losses. Performance ratings do not include the effects of appurtenances (accessories).

# 210 TCN-B/TCNH-B Data

Wheel Diameter = 21"  
Tip Speed (FPM) = 5.50 x RPM

Max. BHP =  
TCN-B =  $1.189 \times (\text{RPM}/1000)^3$   
TCNH-B =  $0.961 \times (\text{RPM}/1000)^3$

Outlet Area - 6.31 FT<sup>2</sup>

Outlet Velocity (FPM) = CFM x 0.16

Max. Motor Frame Size =

TCN-B = 182T

TCNH-B = 213T

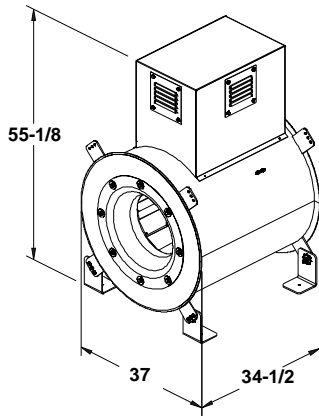

210 TCN-B

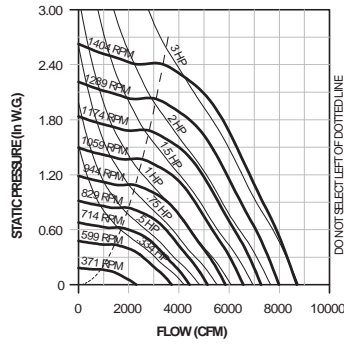

210 TCNH-B

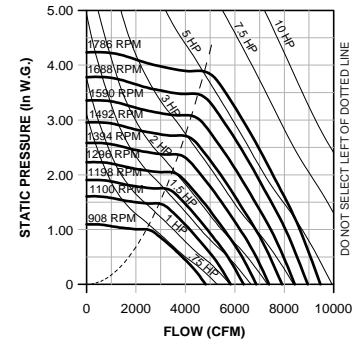

## 210 TCN-B

CFM	OV	0.000" SP		0.250" SP		0.500" SP		0.750" SP		1.000" SP		1.250" SP		1.500" SP		1.750" SP		2.000" SP		2.250" SP		2.500" SP	
		RPM	BHP	RPM	BHP	RPM	BHP	RPM	BHP	RPM	BHP	RPM	BHP	RPM	BHP	RPM	BHP	RPM	BHP	RPM	BHP	RPM	BHP
2300	364	371	.05	541	.19	677	.36	802	.55	910	.75												
2600	412	419	.08	576	.23	699	.40	817	.61	923	.83	1018	1.06										
2900	459	468	.11	614	.27	727	.46	835	.67	938	.91	1031	1.15	1117	1.41								
3200	507	516	.15	652	.33	759	.52	858	.75	955	1.00	1046	1.25	1131	1.52	1210	1.81	1284	2.10				
3500	555	565	.19	691	.39	794	.59	885	.82	975	1.09	1063	1.36	1146	1.64	1224	1.94	1296	2.25	1366	2.57		
3800	602	613	.24	731	.46	830	.67	916	.91	999	1.18	1082	1.47	1162	1.77	1239	2.08	1311	2.40	1379	2.73	1445	3.08
4100	650	662	.31	770	.53	868	.77	950	1.02	1028	1.29	1105	1.59	1181	1.91	1255	2.23	1326	2.56	1394	2.91	1458	3.26
4400	697	710	.38	810	.61	906	.88	986	1.13	1059	1.41	1131	1.72	1203	2.05	1274	2.39	1343	2.74	1409	3.09		
4700	745	758	.46	852	.70	945	.99	1023	1.26	1093	1.55	1161	1.86	1228	2.20	1295	2.55	1361	2.92	1426	3.29		
5000	793	807	.56	894	.81	984	1.12	1060	1.40	1128	1.70	1193	2.02	1257	2.36	1320	2.72	1383	3.10				
5300	840	855	.66	937	.92	1023	1.25	1099	1.56	1165	1.86	1227	2.19	1288	2.54	1348	2.91	1407	3.30				
5600	888	904	.79	981	1.06	1063	1.40	1137	1.73	1203	2.05	1263	2.38	1321	2.73	1378	3.11						
5900	935	952	.92	1025	1.20	1103	1.55	1176	1.91	1240	2.25	1300	2.59	1356	2.95								
6200	983	1000	1.06	1071	1.36	1143	1.72	1215	2.10	1279	2.46	1337	2.82	1391	3.18								
6500	1030	1049	1.23	1115	1.53	1184	1.90	1254	2.30	1317	2.69	1374	3.06										
6800	1078	1097	1.40	1161	1.72	1226	2.09	1294	2.52	1357	2.94												
7100	1126	1146	1.60	1207	1.93	1268	2.30	1334	2.75	1396	3.19												
7400	1173	1194	1.81	1253	2.16	1311	2.53	1374	2.99														
7700	1221	1242	2.04	1299	2.40	1355	2.79	1415	3.25														
8000	1268	1291	2.29	1346	2.66	1399	3.06																
8300	1316	1339	2.55	1393	2.95																		

Shaded area indicates reinforced wheel required. Reinforced wheel required on TCN-B for 1277 RPM or greater.

## 210 TCNH-B

CFM	OV	1.000" SP		1.250" SP		1.500" SP		1.750" SP		2.000" SP		2.250" SP		2.500" SP		2.750" SP		3.000" SP		3.500" SP		4.000" SP	
		RPM	BHP	RPM	BHP	RPM	BHP	RPM	BHP	RPM	BHP	RPM	BHP	RPM	BHP	RPM	BHP	RPM	BHP	RPM	BHP	RPM	BHP
2475	392	908	.67																				
2775	440	930	.76	1015	.94																		
3075	487	963	.85	1037	1.05	1114	1.26																
3375	535	998	.95	1069	1.16	1136	1.38	1206	1.61														
3675	582	1035	1.06	1104	1.28	1168	1.51	1230	1.75	1293	2.00	1361	2.26										
3975	630	1073	1.19	1140	1.42	1203	1.66	1263	1.91	1320	2.17	1377	2.43	1438	2.71								
4275	678	1113	1.33	1178	1.57	1239	1.82	1298	2.08	1353	2.35	1406	2.62	1459	2.91	1514	3.20	1572	3.50				
4575	725	1154	1.48	1217	1.73	1277	2.00	1334	2.27	1388	2.55	1439	2.83	1489	3.12	1539	3.43	1589	3.73				
4875	773	1197	1.64	1257	1.91	1315	2.18	1371	2.47	1424	2.76	1475	3.06	1524	3.36	1571	3.67	1617	3.99	1712	4.65		
5175	820	1240	1.82	1299	2.11	1355	2.39	1409	2.69	1461	2.99	1511	3.30	1559	3.61	1605	3.93	1650	4.26	1738	4.94		
5475	868	1284	2.00	1341	2.31	1396	2.62	1448	2.92	1499	3.23	1548	3.55	1595	3.88	1641	4.21	1685	4.55	1769	5.24		
5775	915	1329	2.20	1385	2.53	1438	2.85	1489	3.17	1538	3.50	1585	3.82	1632	4.16	1677	4.51	1720	4.85				
6075	963	1374	2.41	1429	2.77	1481	3.11	1530	3.44	1578	3.78	1624	4.12	1670	4.47	1714	4.82	1756	5.18				
6375	1011	1419	2.63	1473	3.01	1524	3.37	1573	3.73	1619	4.08	1664	4.43	1708	4.79	1752	5.16						
6675	1058	1466	2.87	1518	3.26	1568	3.65	1616	4.03	1661	4.40	1705	4.76	1748	5.14								
6975	1106	1513	3.12	1564	3.54	1613	3.95	1660	4.35	1704	4.74	1747	5.12										
7275	1153	1561	3.39	1610	3.82	1658	4.26	1704	4.68	1747	5.09												
7575	1201	1610	3.68	1656	4.11	1703	4.57	1748	5.02														
7875	1249	1659	3.99	1704	4.44	1749	4.91																
8175	1296	1710	4.34	1752	4.78																		

Performance certified is for installation type B: free inlet, ducted outlet. Power rating (BHP) does not include drive losses. Performance ratings do not include the effects of appurtenances (accessories).



**225 TCN-B**

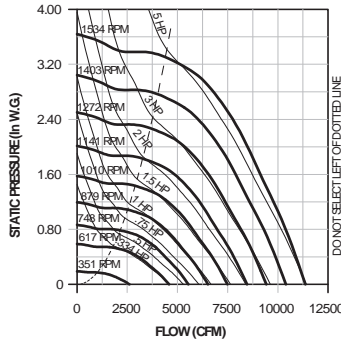

**225 TCNH-B**

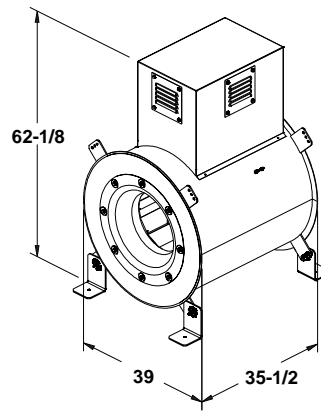
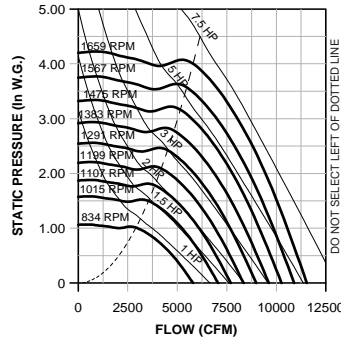

Wheel Diameter = 22.5"  
 Tip Speed (FPM) = 5.89 x RPM  
 Max. BHP =  
 TCN-B = 1.521 x (RPM/1000)<sup>3</sup>  
 TCNH-B = 1.481 x (RPM/1000)<sup>3</sup>  
 Outlet Area = 7.07 FT<sup>2</sup>  
 Outlet Velocity (FPM) = CFM x 0.14  
 Max. Motor Frame Size =  
 TCN-B = 184T  
 TCNH-B = 213T

**225 TCN-B**

CFM	OV	0.000" SP		0.250" SP		0.500" SP		0.750" SP		1.000" SP		1.250" SP		1.500" SP		1.750" SP		2.000" SP		2.250" SP		2.500" SP	
		RPM	BHP	RPM	BHP	RPM	BHP	RPM	BHP	RPM	BHP	RPM	BHP	RPM	BHP	RPM	BHP	RPM	BHP	RPM	BHP	RPM	BHP
2600	367	351	.06	504	.19	631	.37	747	.58	849	.83												
3020	427	407	.09	544	.24	659	.43	764	.65	863	.90	953	1.18										
3440	486	464	.14	588	.31	692	.50	789	.73	880	.99	967	1.27	1048	1.59	1123	1.91						
3860	546	521	.19	634	.38	729	.59	819	.83	903	1.09	984	1.38	1063	1.70	1137	2.04	1206	2.40	1272	2.77		
4280	605	577	.26	680	.47	770	.69	853	.94	932	1.22	1008	1.52	1081	1.83	1152	2.18	1220	2.55	1286	2.94	1348	3.34
4700	664	634	.35	727	.57	814	.82	890	1.07	965	1.37	1036	1.67	1105	2.00	1171	2.34	1237	2.72	1300	3.11	1361	3.52
5120	724	691	.45	775	.69	859	.96	931	1.23	1000	1.52	1068	1.85	1133	2.19	1196	2.54	1257	2.91	1318	3.31	1377	3.72
5540	783	747	.57	825	.82	905	1.11	974	1.40	1039	1.71	1102	2.04	1165	2.40	1225	2.76	1283	3.14	1340	3.54	1396	3.95
5960	843	804	.71	876	.98	951	1.29	1019	1.60	1080	1.91	1140	2.26	1199	2.62	1256	3.00	1312	3.40	1366	3.80	1420	4.23
6380	902	860	.87	928	1.16	997	1.48	1064	1.81	1123	2.15	1179	2.49	1235	2.87	1290	3.27	1344	3.68	1396	4.10	1447	4.53
6800	961	917	1.06	981	1.36	1045	1.69	1110	2.05	1168	2.41	1221	2.76	1274	3.15	1326	3.55	1377	3.97	1428	4.41	1477	4.86
7220	1021	974	1.27	1033	1.58	1094	1.93	1156	2.31	1213	2.69	1265	3.07	1315	3.46	1364	3.86	1413	4.30	1461	4.74	1509	5.21
7640	1080	1030	1.50	1087	1.83	1144	2.20	1202	2.59	1259	3.00	1310	3.40	1358	3.80	1404	4.21	1451	4.65	1497	5.11		
8060	1140	1087	1.76	1141	2.11	1193	2.48	1250	2.90	1304	3.32	1355	3.75	1402	4.17	1447	4.60	1491	5.04				
8480	1199	1144	2.05	1195	2.42	1245	2.81	1297	3.23	1350	3.68	1400	4.13	1447	4.58	1490	5.01	1533	5.47				
8900	1259	1200	2.37	1250	2.76	1296	3.15	1346	3.59	1397	4.06	1446	4.54	1492	5.01	1535	5.47						
9320	1318	1257	2.72	1305	3.14	1350	3.55	1396	3.99	1444	4.47	1492	4.97	1537	5.46								
9740	1377	1314	3.11	1359	3.53	1402	3.96	1446	4.42	1492	4.92	1538	5.43										
10160	1437	1370	3.52	1413	3.96	1455	4.42	1497	4.89	1541	5.40												
10580	1496	1427	3.98	1469	4.45	1509	4.91	1549	5.40														
11000	1556	1484	4.48	1525	4.97	1563	5.45																

Shaded area indicates reinforced wheel required. Reinforced wheel required on TCN-B for 1152 RPM or greater.

**225 TCNH-B**

CFM	OV	1.000" SP		1.250" SP		1.500" SP		1.750" SP		2.000" SP		2.250" SP		2.500" SP		2.750" SP		3.000" SP		3.500" SP		4.000" SP	
		RPM	BHP	RPM	BHP	RPM	BHP	RPM	BHP	RPM	BHP	RPM	BHP	RPM	BHP	RPM	BHP	RPM	BHP	RPM	BHP	RPM	BHP
3000	424	834	.81																				
3350	473	854	.90	932	1.13																		
3700	523	879	.99	952	1.24	1023	1.50																
4050	572	906	1.09	976	1.36	1043	1.64	1108	1.92														
4400	622	936	1.21	1002	1.48	1067	1.77	1128	2.07	1188	2.38	1246	2.68										
4750	671	968	1.34	1031	1.62	1093	1.92	1152	2.23	1209	2.56	1265	2.89	1319	3.22								
5100	721	1002	1.49	1062	1.77	1121	2.08	1178	2.40	1233	2.74	1287	3.09	1339	3.44	1390	3.80	1440	4.15				
5450	770	1037	1.65	1095	1.94	1151	2.25	1206	2.58	1259	2.93	1311	3.29	1361	3.66	1410	4.04	1459	4.42				
5800	820	1074	1.82	1130	2.14	1184	2.46	1236	2.79	1287	3.14	1337	3.51	1386	3.89	1433	4.28	1480	4.69	1570	5.49		
6150	869	1112	2.01	1166	2.34	1217	2.67	1268	3.02	1317	3.37	1365	3.75	1412	4.13	1458	4.54	1503	4.95	1591	5.80		
6500	919	1152	2.22	1203	2.56	1252	2.90	1301	3.26	1348	3.63	1395	4.01	1440	4.40	1485	4.81	1529	5.24	1614	6.12		
6850	969	1193	2.44	1241	2.79	1289	3.16	1335	3.52	1381	3.90	1426	4.29	1470	4.69	1513	5.10	1556	5.54	1639	6.44		
7200	1018	1234	2.67	1280	3.04	1326	3.42	1371	3.81	1415	4.20	1459	4.60	1501	5.00	1543	5.43	1584	5.86				
7550	1068	1276	2.93	1321	3.32	1364	3.70	1408	4.11	1451	4.52	1493	4.93	1534	5.35	1574	5.77	1614	6.21				
7900	1117	1319	3.20	1362	3.61	1404	4.01	1446	4.43	1487	4.85	1528	5.28	1568	5.71	1607	6.15	1646	6.60				
8250	1167	1363	3.50	1404	3.92	1444	4.34	1484	4.76	1524	5.20	1564	5.65	1602	6.08	1641	6.55						
8600	1216	1406	3.81	1446	4.25	1485	4.68	1524	5.13	1563	5.58	1601	6.04	1638	6.49								
8950	1266	1451	4.15	1489	4.60	1527	5.05	1565	5.52	1602	5.98	1638	6.44										
9300	1315	1496	4.52	1533	4.98	1569	5.44	1605	5.91	1641	6.39												
9650	1365	1541	4.90	1577	5.37	1612	5.85	1647	6.34														
10000	1414	1587	5.31	1621	5.79	1656	6.30																

Performance certified is for installation type B: free inlet, ducted outlet. Power rating (BHP) does not include drive losses. Performance ratings do not include the effects of appurtenances (accessories).



# 245 TCN-B/TCNH-B Data

**Wheel Diameter = 24.5"**  
**Tip Speed (FPM) = 6.41 x RPM**  
**Max. BHP =**  
 TCN-B =  $2.512 \times (\text{RPM}/1000)^3$   
 TCNH-B =  $2.299 \times (\text{RPM}/1000)^3$   
**Outlet Area = 8.73 FT<sup>2</sup>**  
**Outlet Velocity (FPM) = CFM x 0.11**  
**Max. Motor Frame Size =**  
 TCN-B = 213T  
 TCNH-B = 215T

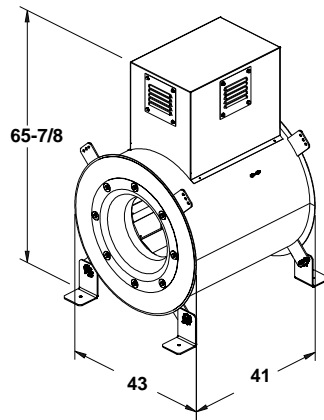

**245 TCN-B**

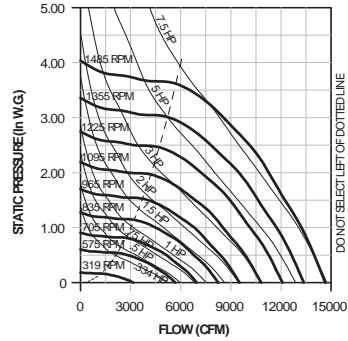

**245 TCNH-B**

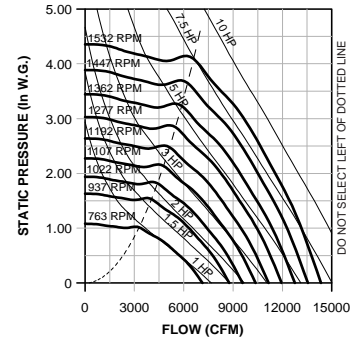

**245 TCN-B**

CFM	OV	0.000" SP		0.250" SP		0.500" SP		0.750" SP		1.000" SP		1.250" SP		1.500" SP		1.750" SP		2.000" SP		2.250" SP		2.500" SP		
		RPM	BHP	RPM	BHP	RPM	BHP	RPM	BHP	RPM	BHP	RPM	BHP	RPM	BHP	RPM	BHP	RPM	BHP	RPM	BHP	RPM	BHP	RPM
3150	360	319	.07	466	.25	588	.47	691	.72	784	.99													
3700	423	375	.12	503	.32	617	.56	713	.83	801	1.13	881	1.45											
4250	487	431	.18	546	.40	648	.67	741	.96	823	1.28	899	1.62	971	1.97	1039	2.34							
4800	550	486	.26	590	.50	681	.79	771	1.11	850	1.44	922	1.80	990	2.18	1056	2.58	1118	2.99	1178	3.40			
5350	613	542	.36	635	.61	721	.94	802	1.28	880	1.64	949	2.01	1014	2.40	1077	2.82	1136	3.26	1194	3.71	1250	4.17	
5900	676	598	.48	680	.75	763	1.10	836	1.47	910	1.85	979	2.25	1042	2.66	1101	3.09	1159	3.55	1214	4.02	1268	4.51	
6450	739	654	.63	728	.91	807	1.28	875	1.68	942	2.09	1009	2.52	1072	2.96	1129	3.39	1184	3.86	1237	4.34	1289	4.85	
7000	802	709	.80	777	1.10	852	1.49	917	1.91	978	2.35	1041	2.81	1102	3.27	1159	3.74	1213	4.22	1264	4.72	1314	5.24	
7550	865	765	1.00	828	1.33	896	1.73	961	2.18	1018	2.64	1075	3.12	1133	3.61	1190	4.12	1243	4.62	1293	5.14	1341	5.66	
8100	928	821	1.24	879	1.58	942	1.99	1005	2.47	1060	2.95	1113	3.46	1166	3.97	1221	4.51	1274	5.06	1323	5.59	1371	6.15	
8650	991	877	1.51	932	1.88	988	2.29	1049	2.79	1104	3.31	1154	3.83	1203	4.37	1253	4.92	1304	5.50	1354	6.08	1401	6.66	
9200	1054	932	1.82	984	2.20	1036	2.63	1094	3.14	1148	3.69	1197	4.25	1243	4.81	1290	5.39	1337	5.98	1385	6.59	1432	7.20	
9750	1117	988	2.16	1037	2.57	1086	3.02	1139	3.53	1193	4.11	1241	4.69	1285	5.28	1329	5.88	1373	6.50	1418	7.13	1463	7.77	
10300	1180	1044	2.55	1091	2.99	1135	3.43	1185	3.96	1237	4.56	1285	5.17	1329	5.79	1370	6.41	1411	7.05	1453	7.70			
10850	1243	1100	2.98	1144	3.44	1187	3.91	1232	4.43	1282	5.05	1329	5.68	1373	6.34	1413	6.99	1453	7.66					
11400	1306	1155	3.45	1197	3.93	1238	4.42	1280	4.95	1327	5.58	1374	6.25	1417	6.93	1457	7.61							
11950	1369	1211	3.98	1251	4.48	1290	4.99	1330	5.54	1373	6.16	1418	6.84	1461	7.55									
12500	1432	1267	4.56	1306	5.09	1343	5.61	1380	6.17	1420	6.79	1463	7.48	1506	8.23									
13050	1495	1323	5.19	1361	5.75	1395	6.28	1431	6.86	1469	7.49	1509	8.19											
13600	1558	1378	5.87	1416	6.47	1448	7.00	1483	7.61	1518	8.24													
14150	1621	1434	6.61	1471	7.25	1502	7.81																	

Shaded area indicates reinforced wheel required. Reinforced wheel required on TCN-B for 1015 RPM or greater.

**245 TCNH-B**

CFM	OV	1.000" SP		1.250" SP		1.500" SP		1.750" SP		2.000" SP		2.250" SP		2.500" SP		2.750" SP		3.000" SP		3.500" SP		4.000" SP	
		RPM	BHP	RPM	BHP	RPM	BHP	RPM	BHP	RPM	BHP	RPM	BHP	RPM	BHP	RPM	BHP	RPM	BHP	RPM	BHP	RPM	BHP
3400	389	763	.93																				
3900	446	791	1.06	859	1.33																		
4400	504	818	1.21	887	1.49	948	1.80																
4900	561	843	1.36	913	1.67	976	2.00	1032	2.33	1084	2.68												
5400	618	873	1.53	938	1.87	1002	2.22	1060	2.57	1112	2.93	1161	3.31	1208	3.69								
5900	676	907	1.72	967	2.08	1027	2.45	1086	2.83	1140	3.21	1190	3.61	1236	4.01	1280	4.43	1323	4.85				
6400	733	943	1.92	1000	2.30	1056	2.70	1111	3.11	1165	3.51	1217	3.93	1264	4.35	1308	4.78	1350	5.22	1430	6.13		
6900	790	981	2.16	1035	2.55	1088	2.97	1140	3.40	1191	3.83	1241	4.27	1290	4.72	1336	5.17	1379	5.63	1457	6.56	1532	7.55
7400	847	1021	2.42	1073	2.83	1123	3.26	1172	3.71	1220	4.17	1267	4.63	1315	5.10	1361	5.58	1405	6.06	1486	7.03		
7900	905	1061	2.70	1112	3.14	1160	3.58	1206	4.04	1252	4.52	1297	5.01	1341	5.50	1386	6.01	1430	6.51	1513	7.54		
8400	962	1102	3.01	1152	3.47	1198	3.93	1243	4.41	1286	4.90	1329	5.41	1371	5.92	1414	6.46	1456	6.99				
8900	1019	1143	3.34	1192	3.83	1237	4.31	1281	4.81	1323	5.32	1364	5.84	1404	6.37	1444	6.92	1484	7.48				
9400	1077	1185	3.70	1232	4.21	1277	4.72	1320	5.25	1360	5.76	1400	6.30	1439	6.86	1477	7.42	1515	8.00				
9900	1134	1228	4.09	1274	4.63	1318	5.17	1359	5.70	1399	6.25	1438	6.81	1475	7.37	1512	7.96						
10400	1191	1273	4.51	1316	5.07	1358	5.63	1400	6.21	1438	6.77	1476	7.35	1513	7.94								
10900	1249	1318	4.97	1359	5.55	1400	6.14	1440	6.73	1478	7.32	1515	7.92										
11400	1306	1364	5.46	1403	6.06	1442	6.67	1481	7.29	1519	7.92												
11900	1363	1412	6.01	1447	6.60	1485	7.24	1523	7.89														
12400	1420	1459	6.58	1493	7.20	1529	7.86																
12900	1478	1507	7.19																				

Performance certified is for installation type B: free inlet, ducted outlet. Power rating (BHP) does not include drive losses. Performance ratings do not include the effects of appurtenances (accessories).

## 270 TCN-B

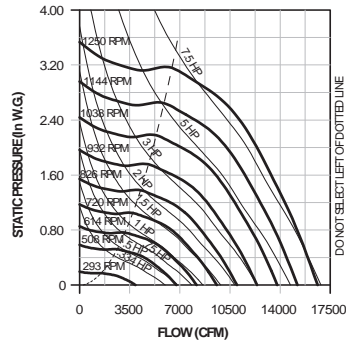

## 270 TCNH-B

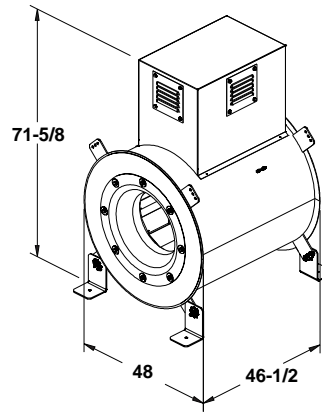
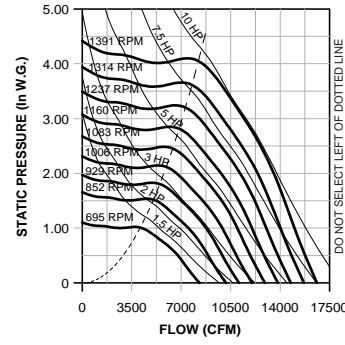

**Wheel Diameter = 27"**  
**Tip Speed (FPM) = 7.07 x RPM**  
**Max. BHP =**  
 TCN-B =  $4.194 \times (\text{RPM}/1000)^3$   
 TCNH-B =  $3.661 \times (\text{RPM}/1000)^3$   
**Outlet Area = 10.56 FT<sup>2</sup>**  
**Outlet Velocity (FPM) = CFM x 0.09**  
**Max. Motor Frame Size =**  
 TCN-B = 213T  
 TCNH-B = 215T

## 270 TCN-B

CFM	OV	0.000" SP		0.250" SP		0.500" SP		0.750" SP		1.000" SP		1.250" SP		1.500" SP		1.750" SP		2.000" SP		2.250" SP		2.500" SP	
		RPM	BHP	RPM	BHP	RPM	BHP	RPM	BHP	RPM	BHP	RPM	BHP	RPM	BHP	RPM	BHP	RPM	BHP	RPM	BHP	RPM	BHP
3900	369	293	.09	417	.30	528	.59	625	.91	708	1.25												
4510	427	339	.14	449	.38	547	.68	640	1.04	722	1.41	795	1.80										
5120	484	385	.21	484	.47	571	.78	656	1.16	736	1.57	809	2.00	875	2.44	936	2.89						
5730	542	431	.29	521	.59	601	.91	677	1.30	752	1.73	823	2.19	889	2.67	950	3.16	1006	3.66	1060	4.17		
6340	600	477	.40	558	.71	633	1.06	703	1.46	772	1.92	839	2.40	903	2.90	964	3.43	1020	3.97	1073	4.51	1123	5.07
6950	658	523	.53	596	.86	668	1.25	732	1.65	795	2.11	858	2.62	920	3.16	978	3.71	1034	4.28	1087	4.86	1137	5.45
7560	715	569	.68	636	1.03	704	1.46	764	1.87	823	2.34	881	2.87	938	3.42	995	4.01	1049	4.60	1102	5.22	1152	5.86
8170	773	614	.85	677	1.23	740	1.68	798	2.13	853	2.60	907	3.14	960	3.71	1013	4.31	1066	4.94	1117	5.59	1166	6.24
8780	831	660	1.06	719	1.46	777	1.93	834	2.43	885	2.91	936	3.44	986	4.03	1035	4.65	1085	5.30	1134	5.97	1182	6.66
9390	889	706	1.30	761	1.72	816	2.22	870	2.75	919	3.26	967	3.79	1014	4.38	1060	5.01	1107	5.69	1154	6.39	1199	7.09
10000	947	752	1.57	803	2.01	854	2.52	906	3.09	954	3.64	1000	4.19	1044	4.78	1088	5.41	1132	6.10	1176	6.82	1220	7.56
10610	1004	798	1.87	847	2.35	894	2.87	943	3.46	990	4.06	1034	4.64	1076	5.23	1118	5.87	1160	6.56	1201	7.28	1242	8.04
11220	1062	844	2.21	890	2.71	935	3.25	981	3.86	1027	4.51	1069	5.12	1110	5.74	1150	6.38	1189	7.06	1228	7.79		
11830	1120	890	2.60	933	3.11	976	3.68	1020	4.31	1063	4.97	1105	5.64	1145	6.30	1183	6.95	1220	7.62				
12440	1178	936	3.02	978	3.57	1018	4.15	1059	4.79	1101	5.49	1142	6.21	1180	6.88	1217	7.56	1253	8.25				
13050	1235	981	3.48	1022	4.06	1060	4.66	1099	5.32	1139	6.04	1178	6.78	1216	7.52	1252	8.23						
13660	1293	1027	3.99	1066	4.60	1103	5.23	1140	5.90	1178	6.64	1215	7.40	1252	8.18								
14270	1351	1073	4.55	1110	5.18	1145	5.82	1180	6.51	1217	7.28	1253	8.07										
14880	1409	1119	5.16	1154	5.80	1188	6.48	1222	7.19	1257	7.97												
15490	1466	1165	5.82	1199	6.50	1232	7.20	1264	7.92														
16100	1524	1211	6.54	1245	7.27	1275	7.96																

Shaded area indicates reinforced wheel required. Reinforced wheel required on TCN-B for 876 RPM or greater.

## 270 TCNH-B

CFM	OV	1.000" SP		1.250" SP		1.500" SP		1.750" SP		2.000" SP		2.250" SP		2.500" SP		2.750" SP		3.000" SP		3.500" SP		4.000" SP	
		RPM	BHP	RPM	BHP	RPM	BHP	RPM	BHP	RPM	BHP	RPM	BHP	RPM	BHP	RPM	BHP	RPM	BHP	RPM	BHP	RPM	BHP
4250	402	695	1.17																				
4750	449	713	1.29	777	1.63																		
5250	497	735	1.44	794	1.78	853	2.16																
5750	544	759	1.60	816	1.96	870	2.34	923	2.75														
6250	591	784	1.77	840	2.17	892	2.56	941	2.96	991	3.41	1040	3.88										
6750	639	810	1.94	865	2.37	916	2.81	963	3.22	1009	3.66	1055	4.13	1100	4.63								
7250	686	837	2.14	890	2.58	940	3.05	987	3.51	1031	3.96	1074	4.42	1117	4.92	1159	5.44	1202	6.00				
7750	733	866	2.37	917	2.82	966	3.30	1012	3.80	1055	4.28	1097	4.77	1137	5.26	1177	5.78	1216	6.32	1296	7.50		
8250	781	896	2.62	944	3.07	991	3.56	1037	4.09	1080	4.62	1121	5.14	1160	5.65	1198	6.18	1235	6.71	1310	7.88		
8750	828	928	2.91	973	3.36	1018	3.85	1062	4.38	1105	4.95	1145	5.50	1184	6.06	1221	6.61	1257	7.15	1328	8.31		
9250	876	961	3.22	1003	3.68	1046	4.18	1089	4.72	1130	5.28	1170	5.88	1209	6.48	1245	7.05	1281	7.64	1349	8.81		
9750	923	995	3.55	1035	4.03	1076	4.55	1117	5.09	1157	5.66	1196	6.27	1234	6.89	1270	7.51	1305	8.13	1372	9.35		
10250	970	1031	3.91	1068	4.42	1106	4.93	1145	5.48	1184	6.06	1222	6.67	1259	7.31	1295	7.97	1330	8.63				
10750	1018	1067	4.30	1102	4.83	1138	5.36	1175	5.92	1212	6.50	1249	7.11	1285	7.76	1321	8.44	1355	9.12				
11250	1065	1103	4.71	1137	5.27	1171	5.82	1207	6.41	1242	6.99	1277	7.60	1312	8.25	1347	8.94	1380	9.63				
11750	1112	1141	5.17	1173	5.74	1206	6.33	1239	6.91	1272	7.50	1306	8.13	1340	8.78	1373	9.45						
12250	1160	1178	5.64	1210	6.25	1241	6.86	1272	7.46	1304	8.07	1336	8.70	1369	9.36								
12750	1207	1217	6.16	1246	6.77	1276	7.40	1306	8.03	1337	8.68	1368	9.33										
13250	1254	1255	6.70	1284	7.35	1313	8.01	1341	8.65	1370	9.30												
13750	1302	1293	7.27	1321	7.94	1349	8.62	1377	9.31														
14250	1349	1332	7.88	1360	8.60	1387	9.30																

Performance certified is for installation type B: free inlet, ducted outlet. Power rating (BHP) does not include drive losses. Performance ratings do not include the effects of appurtenances (accessories).

# 300 TCN-B/TCNH-B Data

Wheel Diameter = 30"

Tip Speed (FPM) = 7.85 x RPM

Max. BHP =

TCN-B = 7.333x (RPM/1000)<sup>3</sup>

TCNH-B = 6.77x (RPM/1000)<sup>3</sup>

Outlet Area = 12.57 FT<sup>2</sup>

Outlet Velocity (FPM) = CFM x 0.08

Max. Motor Frame Size =

TCN-B = 215T

TCNH-B = 254T

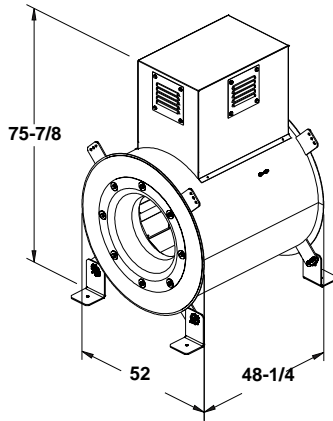

## 300 TCN-B

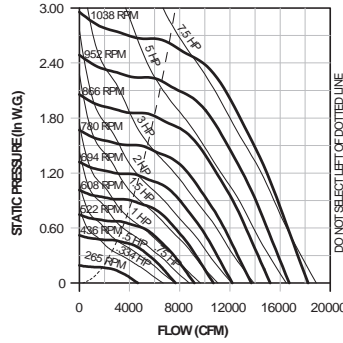

## 300 TCNH-B

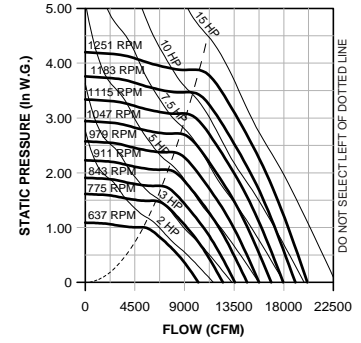

### 300 TCN-B

CFM	OV	0.000" SP		0.250" SP		0.500" SP		0.750" SP		1.000" SP		1.250" SP		1.500" SP		1.750" SP		2.000" SP		2.250" SP		2.500" SP	
		RPM	BHP	RPM	BHP	RPM	BHP	RPM	BHP	RPM	BHP	RPM	BHP	RPM	BHP	RPM	BHP	RPM	BHP	RPM	BHP	RPM	BHP
4650	370	265	.11	382	.41	477	.77	568	1.19	645	1.65												
5300	421	302	.17	408	.50	494	.88	577	1.32	655	1.82	723	2.35										
5950	473	339	.24	435	.59	516	1.01	590	1.47	663	1.98	732	2.55	794	3.14								
6600	525	376	.32	464	.71	541	1.17	608	1.64	675	2.18	741	2.76	803	3.38	860	4.03	912	4.68				
7250	576	413	.43	494	.85	567	1.34	631	1.85	691	2.39	752	2.99	812	3.64	869	4.31	923	5.03	972	5.74	1018	6.47
7900	628	450	.55	526	1.02	593	1.51	655	2.07	712	2.64	767	3.25	823	3.91	878	4.61	931	5.35	982	6.12	1028	6.88
8550	680	487	.70	558	1.21	621	1.72	681	2.32	735	2.92	786	3.54	838	4.22	889	4.94	940	5.69	990	6.48	1038	7.31
9200	732	524	.87	591	1.43	649	1.95	707	2.58	760	3.23	808	3.88	856	4.57	904	5.30	952	6.07	999	6.87	1046	7.72
9850	783	561	1.07	625	1.68	679	2.22	734	2.87	785	3.55	832	4.24	878	4.97	922	5.70	967	6.49	1011	7.30	1056	8.17
10500	835	598	1.29	659	1.95	710	2.52	761	3.17	811	3.90	858	4.65	901	5.39	943	6.15	985	6.94	1027	7.78		
11150	887	635	1.55	693	2.25	742	2.87	790	3.52	838	4.27	883	5.05	926	5.85	966	6.63	1006	7.46				
11800	939	672	1.84	727	2.58	775	3.25	820	3.91	865	4.67	910	5.51	951	6.33	990	7.15	1029	8.01				
12450	990	709	2.16	762	2.95	807	3.65	850	4.34	894	5.12	936	5.96	977	6.84	1016	7.72						
13100	1042	746	2.51	796	3.34	841	4.11	882	4.83	923	5.60	963	6.45	1004	7.38								
13750	1094	783	2.90	831	3.78	874	4.59	914	5.35	952	6.12	991	6.98	1030	7.93								
14400	1145	820	3.33	867	4.26	908	5.12	946	5.91	983	6.71	1020	7.58										
15050	1197	857	3.81	901	4.76	942	5.69	979	6.53	1014	7.34	1050	8.23										
15700	1249	894	4.32	937	5.33	976	6.29	1012	7.18	1046	8.03												
16350	1301	931	4.88	973	5.94	1010	6.93	1045	7.87														
17000	1352	968	5.48	1009	6.60	1045	7.64																
17650	1404	1005	6.14	1044	7.29																		

Shaded area indicates reinforced wheel required. Reinforced wheel required on TCN-B for 837 RPM or greater.

### 300 TCNH-B

CFM	OV	1.000" SP		1.250" SP		1.500" SP		1.750" SP		2.000" SP		2.250" SP		2.500" SP		2.750" SP		3.000" SP		3.500" SP		4.000" SP	
		RPM	BHP	RPM	BHP	RPM	BHP	RPM	BHP	RPM	BHP	RPM	BHP	RPM	BHP	RPM	BHP	RPM	BHP	RPM	BHP	RPM	BHP
5375	427	637	1.60																				
5975	475	649	1.75																				
6575	523	668	1.94	723	2.42	780	2.94																
7175	570	691	2.18	741	2.64	791	3.16	843	3.73														
7775	618	714	2.43	763	2.92	809	3.43	855	3.99	903	4.61												
8375	666	739	2.72	786	3.23	830	3.75	873	4.31	915	4.90	959	5.55										
8975	714	764	3.02	810	3.57	853	4.11	894	4.68	934	5.29	974	5.93	1014	6.60	1056	7.32						
9575	761	790	3.33	835	3.93	877	4.51	917	5.10	955	5.70	993	6.36	1029	7.01	1067	7.73	1106	8.48				
10175	809	818	3.67	861	4.32	902	4.95	941	5.56	978	6.18	1014	6.83	1049	7.50	1084	8.21	1119	8.95	1192	10.60		
10775	857	845	4.00	887	4.71	927	5.39	965	6.05	1002	6.70	1037	7.36	1071	8.05	1104	8.76	1137	9.50	1203	11.10		
11375	905	874	4.38	914	5.12	953	5.86	990	6.56	1026	7.25	1060	7.93	1094	8.65	1126	9.37	1157	10.10	1219	11.70		
11975	952	904	4.80	942	5.55	979	6.32	1016	7.10	1050	7.82	1084	8.55	1117	9.28	1149	10.00	1179	10.80	1239	12.40		
12575	1000	934	5.24	970	6.00	1007	6.83	1042	7.64	1076	8.43	1109	9.20	1141	9.96	1172	10.70	1202	11.50				
13175	1048	965	5.72	1000	6.51	1034	7.34	1069	8.21	1102	9.05	1134	9.87	1166	10.70	1196	11.50	1226	12.30				
13775	1096	996	6.24	1030	7.05	1063	7.90	1096	8.79	1128	9.67	1160	10.60	1191	11.40	1221	12.30	1250	13.10				
14375	1143	1028	6.81	1060	7.62	1092	8.49	1124	9.40	1155	10.30	1186	11.30	1217	12.20	1246	13.10						
14975	1191	1061	7.43	1092	8.27	1122	9.13	1153	10.10	1183	11.00	1213	12.00	1243	13.00								
15575	1239	1093	8.06	1123	8.92	1153	9.83	1182	10.80	1211	11.70	1241	12.80										
16175	1287	1126	8.75	1155	9.64	1184	10.60	1212	11.50	1241	12.50												
16775	1334	1159	9.48	1188	10.40	1215	11.30	1243	12.30														
17375	1382	1193	10.30	1220	11.20	1247	12.20																

Performance certified is for installation type B: free inlet, ducted outlet. Power rating (BHP) does not include drive losses. Performance ratings do not include the effects of appurtenances (accessories).

**330 TCN-B**

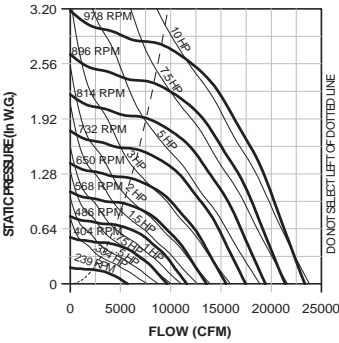

**330 TCNH-B**

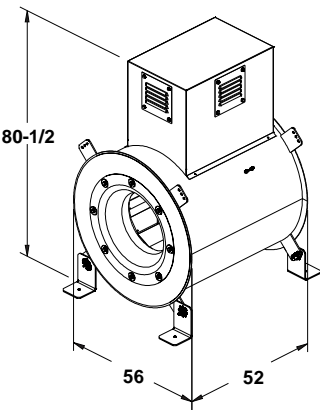
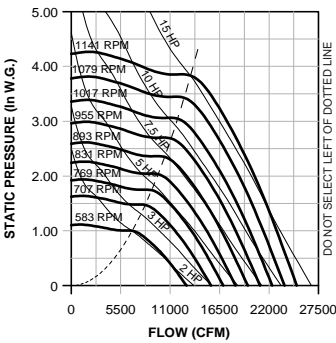

Wheel Diameter = 33"  
 Tip Speed (FPM) = 8.64 x RPM  
 Max. BHP =  
 TCN-B = 11.736 x (RPM/1000)<sup>3</sup>  
 TCNH-B = 10.775 x (RPM/1000)<sup>3</sup>  
 Outlet Area = 14.75 FT<sup>2</sup>  
 Outlet Velocity (FPM) = CFM x 0.07  
 Max. Motor Frame Size =  
 TCN-B = 215T  
 TCNH-B = 254T

**330 TCN-B**

CFM	OV	0.000" SP		0.250" SP		0.500" SP		0.750" SP		1.000" SP		1.250" SP		1.500" SP		1.750" SP		2.000" SP		2.250" SP		2.500" SP	
		RPM	BHP	RPM	BHP	RPM	BHP	RPM	BHP	RPM	BHP	RPM	BHP	RPM	BHP	RPM	BHP	RPM	BHP	RPM	BHP	RPM	BHP
5700	386	239	.14	348	.49	437	.93	518	1.44	588	1.98												
6540	443	274	.21	371	.60	453	1.06	529	1.62	597	2.20	659	2.82										
7380	500	309	.30	395	.72	473	1.22	542	1.79	608	2.44	669	3.11	724	3.79								
8220	557	344	.41	422	.87	496	1.43	559	2.00	621	2.67	680	3.40	734	4.14	785	4.90	834	5.70				
9060	614	380	.55	452	1.06	520	1.65	580	2.26	636	2.92	692	3.69	745	4.48	795	5.30	843	6.15	888	7.00	931	7.88
9900	671	415	.72	482	1.27	543	1.88	603	2.56	655	3.23	707	4.00	758	4.84	807	5.72	853	6.60	897	7.50	939	8.41
10740	728	450	.92	514	1.53	569	2.15	626	2.88	677	3.60	725	4.36	773	5.22	820	6.14	865	7.08	908	8.03	950	9.01
11580	785	485	1.15	545	1.81	596	2.45	650	3.22	700	4.01	745	4.78	789	5.61	834	6.55	878	7.55	920	8.55	961	9.59
12420	842	520	1.42	577	2.13	625	2.81	674	3.58	724	4.45	768	5.28	810	6.12	851	7.03	892	8.02	933	9.08	973	10.20
13260	899	555	1.73	610	2.50	655	3.21	700	3.99	747	4.89	792	5.82	832	6.69	871	7.60	909	8.57	948	9.64	987	10.80
14100	956	591	2.09	642	2.90	686	3.67	727	4.45	771	5.37	815	6.35	855	7.30	892	8.23	929	9.22	965	10.30		
14940	1013	626	2.48	675	3.34	717	4.16	756	4.98	796	5.88	839	6.93	879	7.96	916	8.96	950	9.93	985	11.00		
15780	1069	661	2.92	708	3.84	748	4.70	785	5.54	823	6.47	863	7.53	902	8.62	939	9.70	973	10.70				
16620	1126	696	3.41	742	4.39	780	5.30	816	6.20	851	7.12	888	8.17	926	9.31	963	10.50						
17460	1183	731	3.95	775	4.98	813	5.97	847	6.89	880	7.84	914	8.87	950	10.00								
18300	1240	767	4.56	808	5.62	845	6.66	878	7.64	910	8.63	942	9.67	976	10.80								
19140	1297	802	5.21	842	6.34	877	7.41	909	8.44	940	9.47	970	10.50										
19980	1354	837	5.92	876	7.12	910	8.24	942	9.35	971	10.40												
20820	1411	872	6.70	910	7.95	943	9.13	973	10.30														
21660	1468	907	7.54	943	8.82	975	10.00																
22500	1525	943	8.47	977	9.78																		

Shaded area indicates reinforced wheel required. Reinforced wheel required on TCN-B for 716 RPM or greater.

**330 TCNH-B**

CFM	OV	1.000" SP		1.250" SP		1.500" SP		1.750" SP		2.000" SP		2.250" SP		2.500" SP		2.750" SP		3.000" SP		3.500" SP		4.000" SP	
		RPM	BHP	RPM	BHP	RPM	BHP	RPM	BHP	RPM	BHP	RPM	BHP	RPM	BHP	RPM	BHP	RPM	BHP	RPM	BHP	RPM	BHP
6825	462	583	2.01																				
7625	517	595	2.23	652	2.81																		
8425	571	614	2.49	664	3.09	715	3.73																
9225	625	636	2.78	682	3.40	727	4.05	773	4.74														
10025	679	659	3.09	703	3.75	745	4.43	786	5.13	829	5.89												
10825	733	684	3.44	726	4.13	766	4.84	805	5.59	843	6.34	882	7.14	922	7.97								
11625	788	710	3.82	750	4.54	788	5.28	825	6.05	861	6.84	897	7.66	933	8.50	970	9.39						
12425	842	737	4.24	775	4.99	812	5.77	848	6.58	882	7.39	916	8.24	949	9.10	983	10.00	1017	10.90				
13225	896	764	4.69	801	5.48	837	6.30	871	7.13	905	8.00	937	8.87	969	9.77	1000	10.70	1032	11.60	1096	13.60		
14025	950	793	5.21	828	6.01	862	6.85	896	7.74	928	8.62	959	9.52	990	10.50	1020	11.40	1050	12.40	1109	14.40		
14825	1005	822	5.77	856	6.60	889	7.47	921	8.37	952	9.29	983	10.20	1012	11.20	1042	12.20	1070	13.20	1126	15.20		
15625	1059	852	6.38	884	7.22	916	8.12	947	9.05	977	10.00	1007	11.00	1036	12.00	1064	13.00	1092	14.00				
16425	1113	882	7.03	913	7.91	944	8.84	974	9.80	1003	10.80	1032	11.80	1060	12.80	1088	13.90	1114	14.90				
17225	1167	913	7.75	943	8.67	973	9.62	1002	10.60	1030	11.60	1058	12.70	1085	13.70	1112	14.80	1138	15.90				
18025	1222	945	8.54	974	9.50	1002	10.50	1030	11.50	1057	12.50	1084	13.60	1111	14.70	1137	15.80						
18825	1276	977	9.38	1004	10.30	1031	11.30	1059	12.40	1085	13.40	1111	14.50	1137	15.70								
19625	1330	1009	10.30	1035	11.30	1062	12.30	1088	13.40	1113	14.40	1139	15.60										
20425	1384	1041	11.20	1067	12.30	1093	13.40	1118	14.40														
21225	1439	1074	12.20	1099	13.30	1123	14.40																
22025	1493	1107	13.30	1131	14.40																		

Performance certified is for installation type B: free inlet, ducted outlet. Power rating (BHP) does not include drive losses. Performance ratings do not include the effects of appurtenances (accessories).

# 365 TCN-B/TCNH-B Data

**Wheel Diameter** = 36.5"  
**Tip Speed (FPM)** = 9.56 x RPM  
**Max. BHP** =  
 TCN-B = 20.015 x (RPM/1000)<sup>3</sup>  
 TCNH-B = 18.741 x (RPM/1000)<sup>3</sup>  
**Outlet Area** = 15.9 FT<sup>2</sup>  
**Outlet Velocity (FPM)** = CFM x 0.06  
**Max. Motor Frame Size** =  
 TCN-B = 215T  
 TCNH-B = 256T

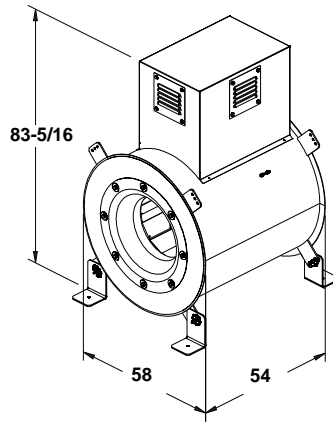

**365 TCN-B**

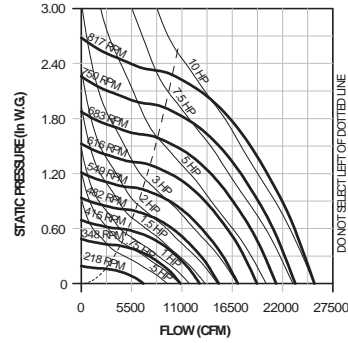

**365 TCNH-B**

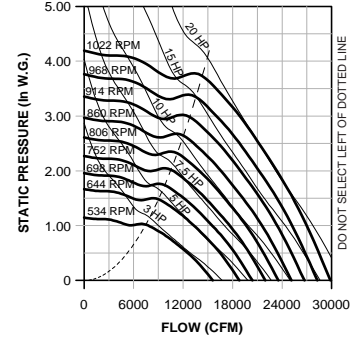

## 365 TCN-B

CFM	OV	0.000" SP		0.250" SP		0.500" SP		0.750" SP		1.000" SP		1.250" SP		1.500" SP		1.750" SP		2.000" SP		2.250" SP		2.500" SP		
		RPM	BHP	RPM	BHP	RPM	BHP	RPM	BHP	RPM	BHP	RPM	BHP	RPM	BHP	RPM	BHP	RPM	BHP	RPM	BHP	RPM	BHP	RPM
6800	427	218	.19	318	.63	404	1.20	479	1.84	543	2.54													
7690	483	247	.28	336	.76	417	1.35	488	2.05	551	2.78													
8580	539	275	.38	356	.91	431	1.53	498	2.26	560	3.05	608	3.58											
9470	595	304	.52	378	1.08	447	1.75	511	2.50	570	3.34	616	3.88	667	4.76									
10360	651	332	.67	400	1.27	465	2.01	525	2.76	581	3.63	625	4.22	675	5.12	722	6.09							
11250	707	361	.86	422	1.49	484	2.28	541	3.08	595	3.96	634	4.56	684	5.53	731	6.54	774	7.57	816	8.68			
12140	763	389	1.08	446	1.74	504	2.58	558	3.44	610	4.35	646	4.95	694	5.97	739	6.99	783	8.08	824	9.21	863	10.40	
13030	819	418	1.34	470	2.03	525	2.90	577	3.85	626	4.78	658	5.32	705	6.41	749	7.50	792	8.63	832	9.76	871	11.00	
13920	875	446	1.63	495	2.36	547	3.27	596	4.26	643	5.26	672	5.75	717	6.86	760	8.02	801	9.18	841	10.40			
14810	931	475	1.97	521	2.73	569	3.66	616	4.70	661	5.78	688	6.28	731	7.37	772	8.54	812	9.77	851	11.00			
15700	987	504	2.35	547	3.15	592	4.11	637	5.19	680	6.32	704	6.83	746	7.94	786	9.13	825	10.40					
16590	1043	532	2.76	573	3.61	615	4.58	658	5.70	700	6.90	721	7.43	761	8.56	800	9.75	838	11.00					
17480	1099	561	3.24	600	4.12	639	5.12	680	6.27	720	7.51	739	8.07	778	9.27	816	10.50							
18370	1155	589	3.75	627	4.69	663	5.69	703	6.91	741	8.17	759	8.79	796	10.00									
19260	1211	618	4.33	653	5.29	688	6.34	725	7.54	763	8.89	778	9.48	814	10.80									
20150	1267	646	4.95	680	5.95	714	7.06	749	8.29	785	9.65	799	10.30											
21040	1323	675	5.65	708	6.71	739	7.80	773	9.08	807	10.50													
21930	1379	703	6.38	735	7.49	765	8.62	797	9.91															
22820	1435	732	7.20	763	8.36	792	9.54	822	10.80															
23710	1491	760	8.06	790	9.27	818	10.50																	
24600	1547	789	9.02	817	10.20																			

Shaded area indicates reinforced wheel required. Reinforced wheel required on TCN-B for 624 RPM or greater.

## 365 TCNH-B

CFM	OV	1.000" SP		1.250" SP		1.500" SP		1.750" SP		2.000" SP		2.250" SP		2.500" SP		2.750" SP		3.000" SP		3.500" SP		4.000" SP	
		RPM	BHP	RPM	BHP	RPM	BHP	RPM	BHP	RPM	BHP	RPM	BHP	RPM	BHP	RPM	BHP	RPM	BHP	RPM	BHP	RPM	BHP
7800	490	534	2.56																				
8700	547	549	2.88	597	3.57																		
9600	603	565	3.24	612	3.98	655	4.73																
10500	660	582	3.61	627	4.40	670	5.22	709	6.02														
11400	716	601	4.02	644	4.86	686	5.74	724	6.59	761	7.49												
12300	773	621	4.46	662	5.36	702	6.28	740	7.20	776	8.14	811	9.12	844	10.10								
13200	830	642	4.95	682	5.90	720	6.87	757	7.86	792	8.84	826	9.85	858	10.90	890	11.90	921	13.00				
14100	886	663	5.47	702	6.45	739	7.49	774	8.52	809	9.59	842	10.60	874	11.70	905	12.80	934	13.90				
15000	943	685	6.06	723	7.07	759	8.15	793	9.24	826	10.30	859	11.50	890	12.60	920	13.70	950	14.90	1005	17.20		
15900	1000	707	6.68	745	7.76	780	8.87	813	10.00	845	11.20	876	12.30	907	13.50	937	14.80	966	16.00	1021	18.40		
16800	1056	730	7.35	766	8.47	801	9.63	833	10.80	865	12.00	895	13.30	924	14.50	953	15.70	982	17.00				
17700	1113	753	8.05	789	9.28	822	10.40	854	11.70	885	12.90	914	14.20	943	15.50	971	16.80	999	18.20				
18600	1169	777	8.81	811	10.10	844	11.30	876	12.60	906	13.90	935	15.20	963	16.60	990	18.00	1017	19.30				
19500	1226	802	9.62	835	11.00	867	12.30	898	13.60	927	14.90	955	16.30	983	17.70	1009	19.10						
20400	1283	827	10.50	858	11.90	889	13.30	920	14.70	949	16.10	977	17.50	1003	18.80								
21300	1339	852	11.40	883	12.90	913	14.40	942	15.80	970	17.20	998	18.70										
22200	1396	879	12.40	908	13.90	936	15.40	965	17.00	993	18.50	1020	20.00										
23100	1452	905	13.40	933	15.00	961	16.60	988	18.20	1015	19.80												
24000	1509	932	14.50	958	16.10	986	17.90	1012	19.50														
24900	1566	959	15.70	985	17.40	1011	19.10																
25800	1622	986	17.00	1011	18.70																		

Performance certified is for installation type B: free inlet, ducted outlet. Power rating (BHP) does not include drive losses. Performance ratings do not include the effects of appurtenances (accessories).



## 402 TCN-B

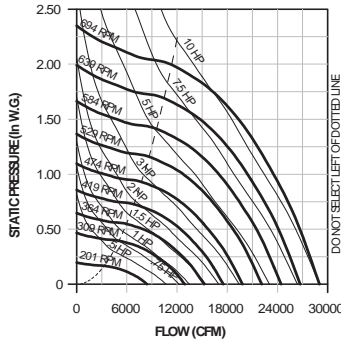

## 402 TCNH-B

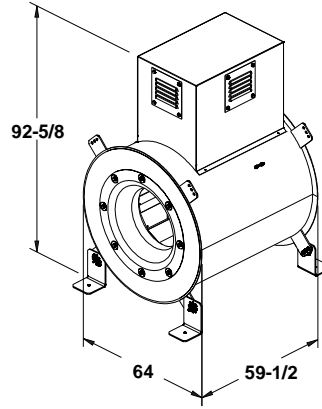
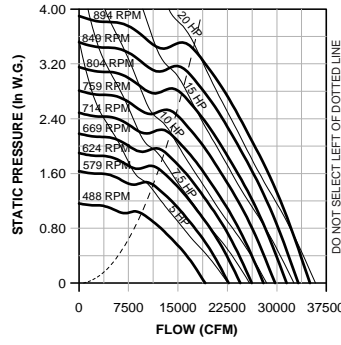

**Wheel Diameter = 40.25"**  
**Tip Speed (FPM) = 10.54 x RPM**  
**Max. BHP =**  
 TCN-B =  $32.638 \times (\text{RPM}/1000)^3$   
 TCNH-B =  $30.707 \times (\text{RPM}/1000)^3$   
**Outlet Area = 19.6 FT<sup>2</sup>**  
**Outlet Velocity (FPM) = CFM x 0.05**  
**Max. Motor Frame Size =**  
 TCN-B = 215T  
 TCNH-B = 256T

## 402 TCN-B

CFM	OV	0.000" SP		0.250" SP		0.500" SP		0.750" SP		1.000" SP		1.250" SP		1.500" SP		1.750" SP		2.000" SP		2.250" SP		2.500" SP	
		RPM	BHP	RPM	BHP	RPM	BHP	RPM	BHP	RPM	BHP	RPM	BHP	RPM	BHP	RPM	BHP	RPM	BHP	RPM	BHP	RPM	BHP
8400	427	201	.24	291	.79	368	1.48	435	2.26	494	3.13												
9390	478	225	.34	306	.94	378	1.64	443	2.50	500	3.39	552	4.37										
10380	528	248	.46	322	1.09	390	1.85	451	2.73	507	3.68	558	4.69	605	5.78								
11370	578	272	.60	340	1.28	404	2.10	462	3.00	516	4.02	566	5.07	612	6.18	655	7.37						
12360	629	296	.78	358	1.49	418	2.37	474	3.29	525	4.34	573	5.45	619	6.62	661	7.81	701	9.09				
13350	679	319	.97	377	1.73	434	2.67	486	3.62	536	4.69	582	5.86	627	7.10	668	8.31	708	9.63	745	11.00		
14340	730	343	1.21	396	1.99	450	2.99	500	4.01	548	5.09	593	6.30	635	7.56	676	8.88	715	10.20				
15330	780	367	1.48	416	2.30	467	3.33	515	4.44	561	5.56	604	6.75	645	8.07	685	9.46	723	10.90				
16320	830	390	1.77	436	2.63	485	3.72	531	4.90	574	6.05	616	7.27	656	8.60	694	10.00						
17310	881	414	2.12	457	3.01	503	4.14	547	5.36	589	6.61	629	7.85	668	9.20	705	10.60						
18300	931	438	2.51	479	3.45	521	4.58	564	5.88	604	7.19	643	8.51	680	9.83								
19290	982	461	2.93	500	3.91	540	5.07	581	6.41	620	7.80	657	9.17	693	10.50								
20280	1032	485	3.41	522	4.44	560	5.63	599	7.01	637	8.47	672	9.89										
21270	1082	509	3.94	544	5.01	580	6.23	617	7.63	654	9.16	688	10.70										
22260	1133	532	4.50	567	5.65	600	6.87	636	8.33	671	9.88												
23250	1183	556	5.14	589	6.32	621	7.59	655	9.07	689	10.70												
24240	1234	580	5.83	611	7.04	642	8.36	674	9.84														
25230	1284	603	6.56	634	7.85	663	9.18	693	10.70														
26220	1335	627	7.37	657	8.72	684	10.00																
27210	1385	651	8.25	679	9.61	706	11.00																
28200	1435	674	9.16	702	10.60																		

Shaded area indicates reinforced wheel required. Reinforced wheel required on TCN-B for 539 RPM or greater.

## 402 TCNH-B

CFM	OV	1.000" SP		1.250" SP		1.500" SP		1.750" SP		2.000" SP		2.250" SP		2.500" SP		2.750" SP		3.000" SP		3.500" SP		4.000" SP	
		RPM	BHP	RPM	BHP	RPM	BHP	RPM	BHP	RPM	BHP	RPM	BHP	RPM	BHP	RPM	BHP	RPM	BHP	RPM	BHP	RPM	BHP
9750	496	488	3.21																				
10750	547	500	3.56																				
11750	598	514	3.97	556	4.87																		
12750	649	528	4.39	569	5.35	607	6.31																
13750	700	543	4.83	583	5.86	620	6.88	656	7.96														
14750	751	560	5.33	598	6.41	634	7.50	669	8.63	702	9.77	733	10.90										
15750	801	577	5.84	614	7.00	648	8.13	682	9.31	715	10.50	746	11.70	775	12.90								
16750	852	594	6.39	630	7.59	664	8.82	697	10.10	728	11.30	759	12.60	788	13.90	816	15.20						
17750	903	612	7.02	647	8.24	680	9.52	712	10.90	742	12.10	772	13.50	801	14.80	829	16.20	855	17.60				
18750	954	631	7.72	665	8.97	697	10.30	728	11.70	757	13.00	786	14.40	814	15.80	842	17.30	868	18.70	919	21.60		
19750	1005	649	8.41	683	9.75	714	11.10	744	12.50	773	14.00	801	15.40	829	16.90	855	18.40	881	19.80				
20750	1056	668	9.17	701	10.60	732	12.00	762	13.50	790	14.90	817	16.50	844	18.00	870	19.60	895	21.10				
21750	1107	688	10.00	720	11.50	750	12.90	779	14.40	807	16.00	833	17.50	859	19.10	885	20.80						
22750	1158	708	10.80	739	12.40	768	13.90	797	15.50	824	17.00	850	18.70	875	20.30	900	22.00						
23750	1209	728	11.70	758	13.40	787	15.00	815	16.60	842	18.20	867	19.80	892	21.50								
24750	1260	749	12.70	778	14.40	806	16.10	833	17.80	859	19.40	885	21.10										
25750	1311	770	13.70	798	15.50	825	17.30	852	19.00	878	20.80												
26750	1362	792	14.80	818	16.60	845	18.50	871	20.30														
27750	1412	813	15.90	839	17.80	865	19.80	890	21.70														
28750	1463	835	17.10	860	19.10	885	21.10																

Performance certified is for installation type B: free inlet, ducted outlet. Power rating (BHP) does not include drive losses. Performance ratings do not include the effects of appurtenances (accessories).



# 445 TCN-B/TCNH-B Data

Wheel Diameter = 44.5"

Tip Speed (FPM) = 11.65 x RPM

Max. BHP =

TCN-B =  $53.913 \times (\text{RPM}/1000)^3$

TCNH-B =  $50.723 \times (\text{RPM}/1000)^3$

Outlet Area = 23.8 FT<sup>2</sup>

Outlet Velocity (FPM) = CFM x 0.04

Max. Motor Frame Size =

TCN-B = 254T

TCNH-B = 326T

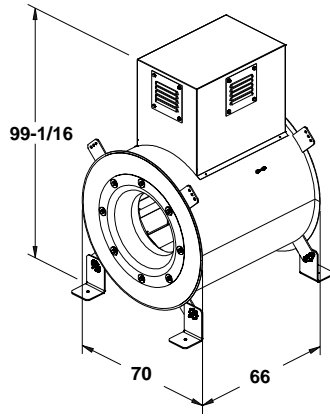

## 445 TCN-B

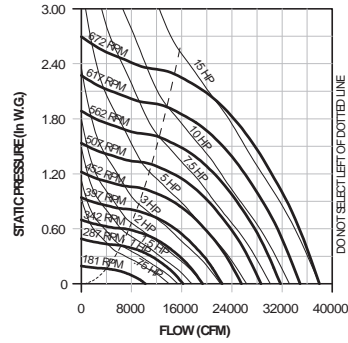

## 445 TCNH-B

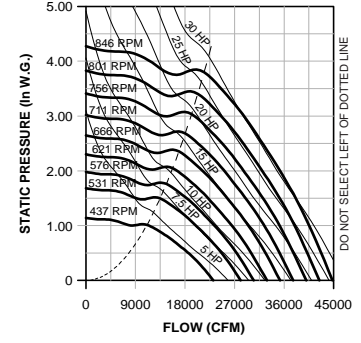

### 445 TCN-B

CFM	OV	0.000" SP		0.250" SP		0.500" SP		0.750" SP		1.000" SP		1.250" SP		1.500" SP		1.750" SP		2.000" SP		2.250" SP		2.500" SP	
		RPM	BHP	RPM	BHP	RPM	BHP	RPM	BHP	RPM	BHP	RPM	BHP	RPM	BHP	RPM	BHP	RPM	BHP	RPM	BHP	RPM	BHP
10200	429	181	.29	262	.96	332	1.79	393	2.75	446	3.81												
11520	484	204	.42	277	1.15	342	2.02	400	3.05	452	4.14	499	5.35										
12840	540	227	.58	294	1.38	354	2.29	409	3.38	460	4.57	506	5.81	548	7.13								
14160	595	251	.78	311	1.62	368	2.64	420	3.74	468	4.99	513	6.30	554	7.64	593	9.11						
15480	651	274	1.02	329	1.91	382	3.00	432	4.15	478	5.44	521	6.83	562	8.27	600	9.75	636	11.30	670	13.00		
16800	707	297	1.30	347	2.22	398	3.41	445	4.63	489	5.93	530	7.37	569	8.87	607	10.40	643	12.10	676	13.70	708	15.50
18120	762	321	1.64	367	2.61	415	3.87	459	5.17	501	6.49	541	7.97	579	9.57	615	11.20	650	12.90	683	14.60	715	16.40
19440	818	344	2.01	387	3.05	432	4.36	474	5.75	514	7.14	552	8.60	589	10.20	624	12.00	658	13.70	691	15.50		
20760	873	367	2.44	407	3.53	450	4.90	490	6.37	528	7.85	565	9.37	600	11.00	634	12.70	667	14.60	699	16.50		
22080	929	391	2.96	428	4.08	468	5.49	506	7.02	543	8.63	578	10.20	612	11.80	645	13.60	677	15.50				
23400	984	414	3.51	450	4.72	486	6.12	523	7.74	558	9.40	592	11.10	625	12.80	657	14.60	688	16.50				
24720	1040	437	4.13	471	5.39	505	6.83	541	8.54	575	10.30	607	12.10	639	13.80	670	15.60						
26040	1095	461	4.84	493	6.16	525	7.64	559	9.38	592	11.20	623	13.10	653	14.90								
27360	1151	484	5.61	515	7.00	545	8.51	577	10.30	609	12.20	639	14.10	668	16.10								
28680	1207	508	6.48	537	7.92	565	9.45	596	11.30	626	13.20	656	15.30										
30000	1262	531	7.40	559	8.90	586	10.50	615	12.40	644	14.30	673	16.50										
31320	1318	554	8.41	581	9.98	607	11.60	634	13.50	663	15.60												
32640	1373	578	9.55	604	11.20	628	12.80	654	14.70														
33960	1429	601	10.70	626	12.40	650	14.20	674	16.10														
35280	1484	624	12.00	649	13.80	671	15.60																
36600	1540	648	13.50	671	15.30																		

Shaded area indicates reinforced wheel required. Reinforced wheel required on TCN-B for 463 RPM or greater.

### 445 TCNH-B

CFM	OV	1.000" SP		1.250" SP		1.500" SP		1.750" SP		2.000" SP		2.250" SP		2.500" SP		2.750" SP		3.000" SP		3.500" SP		4.000" SP	
		RPM	BHP	RPM	BHP	RPM	BHP	RPM	BHP	RPM	BHP	RPM	BHP	RPM	BHP	RPM	BHP	RPM	BHP	RPM	BHP	RPM	BHP
11400	479	437	3.75																				
12800	538	449	4.23	489	5.26																		
14200	597	463	4.79	501	5.87	537	7.00																
15600	656	477	5.35	515	6.56	549	7.73	582	8.97														
17000	715	493	5.98	529	7.26	563	8.55	595	9.86	625	11.20	654	12.50										
18400	774	511	6.70	545	8.05	577	9.40	608	10.80	638	12.20	666	13.60	693	15.10								
19800	833	529	7.46	561	8.84	593	10.30	623	11.80	652	13.30	679	14.80	706	16.30	731	17.90	757	19.50				
21200	892	547	8.28	579	9.76	609	11.30	638	12.90	666	14.40	693	16.00	719	17.60	744	19.30	769	21.00	816	24.40		
22600	951	566	9.21	597	10.70	626	12.30	654	14.00	681	15.60	708	17.40	733	19.00	758	20.80	782	22.50	828	26.00		
24000	1010	585	10.20	616	11.80	644	13.40	671	15.20	697	16.90	723	18.70	748	20.50	772	22.30	796	24.20	841	27.80		
25400	1069	605	11.30	634	12.90	663	14.70	689	16.50	715	18.30	739	20.10	763	22.00	787	24.00	810	25.90				
26800	1127	625	12.40	654	14.20	681	16.00	707	17.80	732	19.70	756	21.70	779	23.60	802	25.60	825	27.60				
28200	1186	646	13.60	673	15.50	700	17.40	726	19.40	750	21.30	774	23.30	796	25.30	818	27.30	840	29.40				
29600	1245	667	14.90	694	17.00	719	18.90	744	20.90	769	23.00	792	25.00	814	27.10	836	29.30						
31000	1304	689	16.20	714	18.40	739	20.50	764	22.70	787	24.70	810	26.80	832	29.00								
32400	1363	711	17.70	735	19.90	759	22.20	783	24.40	806	26.60	829	28.80										
33800	1422	733	19.20	757	21.60	780	24.00	803	26.30	825	28.60												
35200	1481	756	20.90	779	23.40	801	25.80	823	28.30	845	30.70												
36600	1540	779	22.70	801	25.30	822	27.80	844	30.40														
38000	1599	803	24.80	823	27.20	844	29.80																

Performance certified is for installation type B: free inlet, ducted outlet. Power rating (BHP) does not include drive losses. Performance ratings do not include the effects of appurtenances (accessories).

## 490 TCN-B

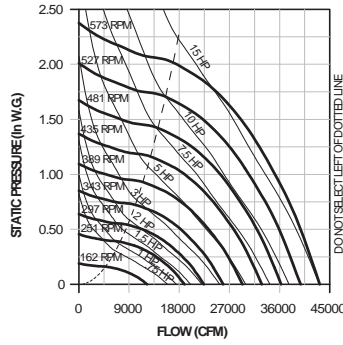

## 490 TCNH-B

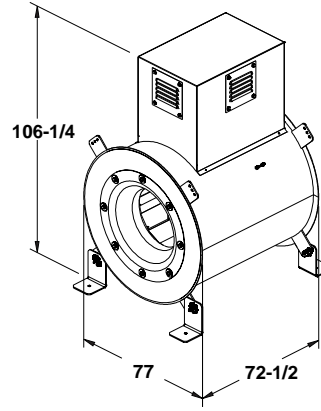
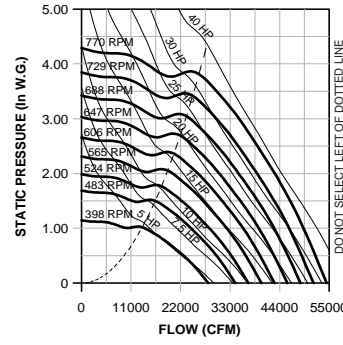

**Wheel Diameter = 49"**  
**Tip Speed (FPM) = 12.83 x RPM**  
**Max. BHP =**  
 TCN-B =  $87.930 \times (\text{RPM}/1000)^3$   
 TCNH-B =  $82.109 \times (\text{RPM}/1000)^3$   
**Outlet Area = 29.1 FT<sup>2</sup>**  
**Outlet Velocity (FPM) = CFM x 0.03**  
**Max. Motor Frame Size =**  
 TCN-B = 254T  
 TCNH-B = 326T

## 490 TCN-B

CFM	OV	0.000" SP		0.250" SP		0.500" SP		0.750" SP		1.000" SP		1.250" SP		1.500" SP		1.750" SP		2.000" SP		2.250" SP		2.500" SP		
		RPM	BHP	RPM	BHP	RPM	BHP	RPM	BHP	RPM	BHP	RPM	BHP	RPM	BHP	RPM	BHP	RPM	BHP	RPM	BHP	RPM	BHP	RPM
12250	421	162	.34	237	1.14	301	2.15	357	3.32	405	4.59													
13720	471	182	.48	249	1.35	309	2.40	363	3.66	410	4.97	452	6.39											
15190	522	201	.65	263	1.60	319	2.70	370	4.02	416	5.41	458	6.90	496	8.48									
16660	573	221	.86	277	1.86	330	3.06	378	4.38	422	5.86	464	7.44	502	9.09	537	10.80							
18130	623	240	1.11	292	2.16	342	3.46	388	4.82	430	6.36	470	8.01	507	9.69	542	11.50	575	13.40					
19600	674	260	1.41	307	2.50	354	3.88	398	5.31	439	6.89	477	8.60	514	10.40	548	12.20	581	14.20	611	16.20			
21070	724	279	1.74	323	2.89	368	4.37	409	5.86	449	7.48	486	9.27	521	11.10	554	13.00	586	15.00					
22540	775	299	2.14	340	3.36	382	4.88	421	6.48	459	8.13	495	9.93	529	11.90	561	13.90	593	16.00					
24010	825	318	2.57	356	3.83	397	5.46	434	7.15	470	8.87	505	10.70	538	12.70	569	14.70							
25480	876	338	3.09	374	4.42	411	6.04	448	7.88	482	9.69	515	11.50	547	13.50	578	15.70							
26950	927	357	3.64	391	5.03	427	6.74	462	8.64	495	10.60	526	12.40	557	14.40									
28420	977	377	4.29	409	5.73	442	7.45	476	9.44	508	11.50	538	13.50	568	15.50									
29890	1028	396	4.97	427	6.50	458	8.25	490	10.30	521	12.40	551	14.60											
31360	1078	416	5.76	445	7.33	474	9.11	505	11.20	535	13.40	564	15.70											
32830	1129	435	6.59	463	8.24	491	10.10	521	12.30	550	14.60													
34300	1179	455	7.54	482	9.27	508	11.10	536	13.30	564	15.70													
35770	1230	474	8.52	500	10.30	525	12.20	552	14.50															
37240	1281	494	9.65	519	11.50	543	13.50	568	15.70															
38710	1331	513	10.80	537	12.70	560	14.80																	
40180	1382	533	12.10	556	14.10	578	16.20																	
41650	1432	552	13.50	575	15.60																			

Shaded area indicates reinforced wheel required. Reinforced wheel required on TCN-B for 360 RPM or greater.

## 490 TCNH-B

CFM	OV	1.000" SP		1.250" SP		1.500" SP		1.750" SP		2.000" SP		2.250" SP		2.500" SP		2.750" SP		3.000" SP		3.500" SP		4.000" SP	
		RPM	BHP	RPM	BHP	RPM	BHP	RPM	BHP	RPM	BHP	RPM	BHP	RPM	BHP	RPM	BHP	RPM	BHP	RPM	BHP	RPM	BHP
14000	481	398	4.61																				
15600	536	408	5.15	444	6.39																		
17200	591	420	5.78	455	7.11	487	8.45																
18800	646	433	6.47	467	7.90	498	9.31	528	10.80														
20400	701	446	7.16	479	8.71	510	10.30	539	11.80	566	13.40												
22000	756	461	7.95	492	9.57	522	11.20	550	12.90	577	14.50	603	16.30	628	18.10								
23600	811	476	8.78	506	10.50	535	12.30	562	14.00	589	15.80	614	17.60	638	19.40	662	21.30						
25200	866	492	9.73	521	11.50	549	13.40	575	15.20	601	17.10	626	19.00	650	21.00	673	22.90	695	24.90				
26800	921	508	10.80	536	12.50	563	14.50	589	16.50	614	18.50	638	20.50	661	22.40	684	24.50	706	26.60	748	30.80		
28400	976	524	11.80	552	13.80	578	15.70	603	17.80	627	19.90	651	22.00	674	24.20	696	26.30	717	28.40	759	32.80		
30000	1031	541	13.00	568	15.00	594	17.10	618	19.20	642	21.40	664	23.60	686	25.80	708	28.10	729	30.30	770	34.90		
31600	1087	558	14.30	584	16.40	610	18.60	634	20.80	656	22.90	679	25.30	700	27.60	721	30.00	742	32.40				
33200	1142	576	15.70	601	17.90	626	20.10	649	22.30	672	24.70	693	27.00	714	29.50	735	32.00	755	34.40				
34800	1197	594	17.10	618	19.40	642	21.80	665	24.10	687	26.50	709	29.00	729	31.40	749	34.00	768	36.50				
36400	1252	612	18.50	635	21.00	659	23.60	681	25.90	703	28.40	724	30.90	744	33.50	764	36.20						
38000	1307	631	20.10	653	22.70	676	25.40	698	28.00	719	30.50	740	33.10	760	35.80								
39600	1362	650	21.90	672	24.60	693	27.30	715	30.10	735	32.70	756	35.40										
41200	1417	669	23.60	690	26.50	711	29.40	732	32.30	752	35.00												
42800	1472	689	25.60	709	28.50	729	31.50	749	34.50	769	37.40												
44400	1527	708	27.60	728	30.70	747	33.70	767	36.90														
46000	1582	728	29.90	747	32.90	766	36.10																

Performance certified is for installation type B: free inlet, ducted outlet. Power rating (BHP) does not include drive losses. Performance ratings do not include the effects of appurtenances (accessories).

# TCN-D/TCNH-D Sound Data

## 60 TCN-D

RPM	SP	SOUND POWER re 10 <sup>-12</sup> WATTS								
		OCTAVE BANDS								L <sub>wi</sub> A
		1	2	3	4	5	6	7	8	
1140	0.000	65	66	58	59	57	45	39	35	61
	0.250	64	66	57	56	56	39	36	34	59
1725	0.000	73	77	69	70	69	62	52	46	73
	0.250	73	77	68	69	68	61	50	44	72
	0.500	72	76	67	67	66	59	49	42	70
	0.750	71	75	65	66	65	57	48	42	68
3450	0.000	86	94	97	89	88	86	77	67	94
	0.500	85	94	97	88	87	86	77	66	93
	1.000	85	93	97	88	87	85	77	65	93
	1.500	84	93	96	87	86	84	75	65	92
	2.000	84	92	96	87	85	83	74	64	92
	2.500	83	92	96	86	84	82	73	64	91
	3.000	83	91	95	85	84	81	73	63	90

## 70 TCN-D

RPM	SP	SOUND POWER re 10 <sup>-12</sup> WATTS								
		OCTAVE BANDS								L <sub>wi</sub> A
		1	2	3	4	5	6	7	8	
1140	0.000	72	67	65	59	55	44	41	33	61
	0.250	70	63	61	55	52	44	43	35	58
1725	0.000	79	82	76	74	68	60	52	47	75
	0.250	78	81	74	72	66	59	52	47	73
	0.500	78	80	72	71	65	59	53	48	72
	0.750	75	78	71	69	62	58	53	50	70
3450	0.000	91	100	103	95	92	84	76	67	98
	0.500	91	99	102	94	91	83	75	67	97
	1.000	90	99	101	93	90	82	74	67	96
	1.500	90	99	101	92	89	82	75	68	96
	2.000	90	98	100	92	88	81	75	68	95
	2.500	88	97	99	91	87	80	74	68	94
	3.000	87	95	98	90	86	79	73	68	93

## 60 TCNH-D

RPM	SP	SOUND POWER re 10 <sup>-12</sup> WATTS								
		OCTAVE BANDS								L <sub>wi</sub> A
		1	2	3	4	5	6	7	8	
1140	0.000	64	67	58	58	57	44	39	35	60
	0.250	63	67	56	57	55	39	36	34	59
1725	0.000	74	78	71	72	72	64	52	45	75
	0.250	73	77	70	71	71	63	52	43	74
	0.500	72	77	68	69	68	60	49	43	71
3450	0.000	87	95	98	91	91	89	80	67	96
	0.500	86	94	98	90	90	88	79	67	95
	1.000	85	93	97	90	90	88	79	67	95
	1.500	85	93	97	89	88	86	77	66	94
	2.000	85	93	97	88	87	85	76	65	93
	2.500	85	93	97	87	86	84	75	64	92

## 70 TCNH-D

RPM	SP	SOUND POWER re 10 <sup>-12</sup> WATTS								
		OCTAVE BANDS								L <sub>wi</sub> A
		1	2	3	4	5	6	7	8	
1140	0.000	86	65	60	63	59	48	38	33	65
	0.250	68	63	56	58	55	45	35	32	59
1725	0.000	94	90	72	73	72	65	53	45	78
	0.250	88	86	71	71	70	63	52	44	75
	0.500	78	80	69	69	68	61	50	43	72
3450	0.000	107	115	110	91	90	88	80	68	104
	0.500	103	112	108	91	90	87	79	68	102
	1.000	100	108	106	91	89	86	78	67	100
	1.500	95	104	103	89	88	85	77	66	97
	2.000	91	99	100	88	87	85	77	66	95
	2.500	87	95	98	87	86	83	76	65	93

The sound power level ratings shown are in decibels referred to 10<sup>-12</sup> watts calculated per AMCA Standard 301. The A-weighted sound ratings shown have been calculated per AMCA Standard 301. Values shown are for inlet L<sub>wi</sub> and inlet L<sub>wi</sub>A sound power levels for Installation Type B: free inlet, ducted outlet.

**80 TCN-D**

RPM	SP	SOUND POWER re 10 <sup>-12</sup> WATTS								
		OCTAVE BANDS								L <sub>wi</sub> A
		1	2	3	4	5	6	7	8	
1140	0.000	78	66	59	60	59	49	40	35	62
	0.250	70	64	56	57	54	48	38	34	59
1725	0.000	87	86	71	71	70	64	54	47	75
	0.250	76	80	71	70	68	63	54	46	73
	0.500	77	80	69	68	66	62	53	45	71
	0.750	78	79	67	66	65	60	52	44	70
3450	0.000	99	107	106	90	88	86	79	69	99
	0.500	93	102	103	90	87	85	79	69	96
	1.000	88	96	100	89	87	84	78	69	94
	1.500	88	97	100	89	86	83	78	68	94
	2.000	89	98	100	88	85	82	77	68	94
	2.500	90	98	100	87	84	81	76	68	93
3.000	90	98	99	86	83	80	76	67	93	

**100 TCN-D**

RPM	SP	SOUND POWER re 10 <sup>-12</sup> WATTS								
		OCTAVE BANDS								L <sub>wi</sub> A
		1	2	3	4	5	6	7	8	
1140	0.000	62	63	58	58	58	54	45	37	62
	0.250	62	62	56	55	52	48	41	35	57
1725	0.000	70	75	69	68	68	66	59	50	72
	0.250	68	73	69	67	66	63	58	50	71
	0.500	68	73	68	66	63	60	55	49	69
	0.750	75	77	67	65	62	59	52	46	68
3450	0.000	82	90	94	87	84	83	81	74	91
	0.500	81	89	93	86	84	82	79	73	90
	1.000	80	88	92	86	83	81	78	73	90
	1.500	80	88	92	86	83	80	77	71	89
	2.000	80	88	92	85	82	79	75	70	89
	2.500	83	91	94	85	81	78	75	69	89
3.000	87	95	96	84	81	78	74	68	90	

**80 TCNH-D**

RPM	SP	SOUND POWER re 10 <sup>-12</sup> WATTS								
		OCTAVE BANDS								L <sub>wi</sub> A
		1	2	3	4	5	6	7	8	
1140	0.000	64	63	67	60	57	47	43	35	63
	0.250	62	60	64	56	53	45	42	35	59
1725	0.000	71	76	76	75	69	63	55	49	75
	0.250	70	75	74	73	67	62	54	48	74
	0.500	69	74	73	73	66	60	53	48	72
	0.750	69	73	70	69	63	58	52	49	70
3450	0.000	83	92	96	94	92	85	78	70	96
	0.500	83	91	95	93	91	84	77	69	95
	1.000	82	91	95	93	90	82	76	69	94
	1.500	82	90	94	92	90	82	76	69	94
	2.000	81	90	94	92	89	81	75	69	93
	2.500	81	90	93	91	88	80	75	68	92
3.000	81	90	93	89	86	79	74	68	91	

**100 TCNH-D**

RPM	SP	SOUND POWER re 10 <sup>-12</sup> WATTS								
		OCTAVE BANDS								L <sub>wi</sub> A
		1	2	3	4	5	6	7	8	
1140	0.000	57	62	59	57	56	54	42	35	61
	0.250	58	61	57	56	53	47	38	33	57
1725	0.000	65	72	70	68	66	65	58	48	72
	0.250	69	74	70	69	66	62	55	46	71
	0.500	66	72	68	67	64	60	53	45	69
	0.750	64	71	66	65	63	59	52	45	67
3450	0.000	77	85	91	87	84	82	80	73	90
	0.500	79	87	92	87	84	81	79	72	90
	1.000	81	90	93	87	84	81	77	70	90
	1.500	80	88	92	87	84	80	76	69	90
	2.000	78	86	91	86	83	80	75	68	89
	2.500	77	85	90	85	82	79	75	68	88
3.000	76	84	90	84	81	78	74	67	87	

The sound power level ratings shown are in decibels referred to 10<sup>-12</sup> watts calculated per AMCA Standard 301. The A-weighted sound ratings shown have been calculated per AMCA Standard 301. Values shown are for inlet L<sub>wi</sub> and inlet L<sub>wi</sub>A sound power levels for Installation Type B: free inlet, ducted outlet.

# TCN-D/TCNH-D Sound Data

## 120 TCN-D

RPM	SP	SOUND POWER re 10 <sup>-12</sup> WATTS								
		OCTAVE BANDS								L <sub>wi</sub> A
		1	2	3	4	5	6	7	8	
1140	0.000	65	67	63	62	59	60	53	42	65
	0.250	68	67	61	61	59	57	49	40	64
1725	0.000	73	78	74	73	70	69	66	57	76
	0.250	74	79	73	72	70	68	65	56	75
	0.500	74	79	73	72	70	68	63	55	75
	0.750	79	82	72	70	69	67	62	53	75
3450	1.000	83	84	71	69	68	67	61	51	74
	0.000	85	93	97	92	89	86	84	81	95
	0.500	85	93	98	91	88	85	84	80	95
	1.000	86	94	98	90	88	85	83	80	94
	1.500	86	94	98	90	87	85	83	79	95
	2.000	86	95	98	90	87	85	83	78	95
2.500	88	96	99	90	87	85	82	78	95	
3.000	91	99	101	90	86	84	82	77	95	

## 135 TCN-D

RPM	SP	SOUND POWER re 10 <sup>-12</sup> WATTS								
		OCTAVE BANDS								L <sub>wi</sub> A
		1	2	3	4	5	6	7	8	
1140	0.000	69	72	68	69	65	61	53	46	70
	0.250	68	71	67	68	63	59	51	44	69
	0.500	75	71	65	65	60	57	49	43	66
1725	0.000	77	82	79	79	77	73	67	59	81
	0.250	76	81	79	79	77	72	66	58	81
	0.500	76	81	78	78	76	71	65	58	80
	0.750	76	81	77	77	75	70	64	57	79
	1.000	80	84	76	75	73	69	63	56	78
1.250	85	87	76	74	71	68	63	56	78	

## 120 TCNH-D

RPM	SP	SOUND POWER re 10 <sup>-12</sup> WATTS								
		OCTAVE BANDS								L <sub>wi</sub> A
		1	2	3	4	5	6	7	8	
1140	0.000	60	67	63	65	57	57	55	39	65
	0.250	63	66	61	63	55	53	50	36	63
1725	0.000	68	76	74	74	71	66	66	58	76
	0.250	70	77	74	74	70	65	64	56	75
	0.500	70	76	73	73	70	64	62	54	74
	0.750	73	78	72	71	68	62	59	52	73
3450	1.000	77	80	71	69	66	60	57	50	72
	0.000	80	88	95	92	90	86	82	81	95
	0.500	81	89	95	92	90	86	81	80	95
	1.000	83	91	96	91	90	85	80	79	95
	1.500	82	90	96	91	89	85	79	78	94
	2.000	82	90	95	90	89	85	79	77	94
2.500	83	91	96	90	88	84	78	76	93	
3.000	85	93	97	89	87	83	77	74	93	

## 135 TCNH-D

RPM	SP	SOUND POWER re 10 <sup>-12</sup> WATTS								
		OCTAVE BANDS								L <sub>wi</sub> A
		1	2	3	4	5	6	7	8	
1140	0.000	62	68	69	69	81	72	52	46	82
	0.250	61	68	68	67	63	58	48	42	68
	0.500	62	69	65	63	55	52	45	40	64
1725	0.000	70	77	78	79	83	87	73	59	90
	0.250	69	76	77	78	77	75	66	57	81
	0.500	69	76	77	78	75	71	64	55	80
	0.750	69	76	78	78	73	68	62	54	78
	1.000	69	77	77	76	71	65	60	53	76
1.250	69	77	75	74	68	62	57	52	74	

The sound power level ratings shown are in decibels referred to 10<sup>-12</sup> watts calculated per AMCA Standard 301. The A-weighted sound ratings shown have been calculated per AMCA Standard 301. Values shown are for inlet L<sub>wi</sub> and inlet L<sub>wi</sub>A sound power levels for Installation Type B: free inlet, ducted outlet.

**150 TCN-D**

RPM	SP	SOUND POWER re 10 <sup>-12</sup> WATTS								
		OCTAVE BANDS								L <sub>wi</sub> A
		1	2	3	4	5	6	7	8	
1140	0.000	71	74	70	71	69	65	57	49	73
	0.250	70	73	69	70	66	64	55	49	71
	0.500	69	73	68	68	63	62	54	48	69
	0.750	77	73	67	67	61	59	53	47	68
1725	0.000	78	84	81	80	79	76	71	63	84
	0.250	77	84	80	80	78	75	70	63	83
	0.500	77	83	80	79	77	74	70	62	82
	0.750	76	83	79	79	76	73	69	61	81
	1.000	75	82	79	78	75	72	68	61	81
	1.250	78	83	79	78	75	71	68	60	80
	1.500	82	86	78	77	74	70	67	60	80
	1.750	85	88	78	77	73	69	66	60	80

**165 TCN-D**

RPM	SP	SOUND POWER re 10 <sup>-12</sup> WATTS								
		OCTAVE BANDS								L <sub>wi</sub> A
		1	2	3	4	5	6	7	8	
1140	0.000	70	73	76	73	67	65	60	54	75
	0.250	68	73	75	72	65	64	59	53	73
	0.500	66	73	75	71	65	65	58	52	73
	0.750	75	73	73	71	65	64	57	50	72
1725	0.000	78	83	85	85	80	76	72	67	86
	0.250	77	83	84	85	79	75	72	66	85
	0.500	76	82	84	84	79	74	71	66	85
	0.750	75	82	84	83	78	73	71	65	84
	1.000	74	81	83	83	78	74	71	65	84
	1.250	73	81	83	83	78	74	71	65	84
	1.500	77	83	83	83	78	74	71	64	84
	1.750	83	87	82	82	78	74	70	63	83
	2.000	90	91	81	81	78	73	69	62	83

**150 TCNH-D**

RPM	SP	SOUND POWER re 10 <sup>-12</sup> WATTS								
		OCTAVE BANDS								L <sub>wi</sub> A
		1	2	3	4	5	6	7	8	
1140	0.000	66	72	74	70	66	68	57	48	74
	0.250	65	72	76	69	64	64	53	45	72
	0.500	63	71	76	68	61	59	51	44	71
	0.750	70	71	75	67	59	56	50	43	70
1725	0.000	73	80	83	83	78	76	73	63	84
	0.250	72	80	83	83	77	75	71	61	84
	0.500	72	79	84	83	76	73	69	60	83
	0.750	71	79	84	83	75	72	68	58	83
	1.000	70	78	84	83	74	70	66	57	83
	1.250	72	79	84	83	74	69	64	57	82
	1.500	75	81	84	82	73	68	63	56	82
	1.750	78	83	84	82	73	67	63	56	82

**165 TCNH-D**

RPM	SP	SOUND POWER re 10 <sup>-12</sup> WATTS								
		OCTAVE BANDS								L <sub>wi</sub> A
		1	2	3	4	5	6	7	8	
1140	0.000	65	72	75	75	66	67	57	50	75
	0.250	63	72	75	74	65	64	56	49	74
	0.500	63	71	74	73	64	62	55	49	72
	0.750	62	70	72	70	63	60	53	48	70
1725	0.000	73	80	84	85	81	76	72	63	86
	0.250	72	79	83	85	80	75	71	63	85
	0.500	71	79	83	84	79	74	70	62	85
	0.750	70	78	83	84	79	73	69	62	84
	1.000	70	78	82	84	78	73	68	62	84
	1.250	70	78	82	83	78	72	68	61	83
	1.500	70	77	81	82	77	71	67	61	83
	1.750	69	77	80	81	76	71	66	60	81
	2.000	69	77	79	80	75	70	65	59	80

The sound power level ratings shown are in decibels referred to 10<sup>-12</sup> watts calculated per AMCA Standard 301. The A-weighted sound ratings shown have been calculated per AMCA Standard 301. Values shown are for inlet L<sub>wi</sub> and inlet L<sub>wi</sub>A sound power levels for Installation Type B: free inlet, ducted outlet.



# TCN-B/TCNH-B Sound Data

## 60 TCN-B

RPM	SP	SOUND POWER re 10 <sup>-12</sup> WATTS								
		OCTAVE BANDS								L <sub>wi</sub> A
		1	2	3	4	5	6	7	8	
400	0.000	28	29	28	23	22	17	10	3	27
600	0.000	41	41	41	38	33	30	23	16	39
800	0.000	50	49	50	48	41	39	32	25	49
1000	0.000	57	56	56	55	49	45	39	32	56
1200	0.000	63	62	62	61	56	50	45	38	61
	0.250	61	60	59	57	53	48	44	37	59
1400	0.000	68	66	66	65	62	54	50	43	66
	0.250	66	65	64	63	59	53	49	42	64
1800	0.000	74	74	73	73	70	62	57	51	74
	0.250	73	73	71	72	68	60	57	50	73
	0.500	72	73	70	70	67	60	56	50	72
2200	0.250	77	80	78	78	75	68	62	57	79
	0.750	76	79	77	76	73	67	62	56	78
2600	0.000	81	86	84	84	81	75	67	63	85
	0.750	79	84	83	82	79	73	66	62	84
	1.250	79	84	82	81	78	72	66	62	83
3000	0.000	83	91	89	88	86	81	71	68	90
	1.000	81	89	87	86	84	78	70	66	88
	1.750	81	89	87	85	82	77	70	66	87
3400	0.000	85	94	93	91	89	85	75	71	94
	1.000	83	92	92	89	88	83	74	70	92
	2.000	83	92	91	88	87	81	74	70	91
3800	0.250	87	95	96	94	92	88	79	74	97
	1.000	86	94	95	93	91	87	78	73	96
	2.500	85	94	95	92	90	85	77	73	94

## 70 TCN-B

RPM	SP	SOUND POWER re 10 <sup>-12</sup> WATTS								
		OCTAVE BANDS								L <sub>wi</sub> A
		1	2	3	4	5	6	7	8	
600	0.000	44	42	43	41	35	31	25	19	42
800	0.000	55	50	51	51	44	40	34	28	51
1000	0.000	64	58	57	57	52	46	41	35	58
1200	0.000	72	65	63	62	58	52	46	40	63
	0.250	64	61	60	59	56	51	46	39	61
1400	0.000	79	70	67	66	64	56	51	45	68
	0.250	71	67	65	65	61	55	51	44	66
1800	0.000	86	80	75	74	72	64	59	53	76
	0.250	82	77	73	73	70	64	58	52	74
	0.500	77	76	72	71	68	63	58	52	73
2200	0.000	90	89	82	79	77	71	65	59	82
	0.250	87	87	80	79	77	71	64	58	81
	0.750	80	82	79	77	74	69	64	58	79
2600	0.000	93	96	88	84	82	77	70	64	88
	0.750	86	90	85	82	80	75	69	64	85
	1.250	81	87	84	81	79	74	69	64	84
3000	0.000	95	102	93	88	86	82	74	68	92
	1.000	88	96	90	86	85	80	73	68	90
	1.750	83	91	89	85	83	78	73	68	88
3400	0.000	97	106	98	92	90	86	78	72	96
	1.000	92	101	95	90	89	84	77	72	94
	2.000	87	95	93	89	87	83	76	72	92
3800	0.250	98	107	102	95	93	89	82	75	99
	1.250	94	102	99	94	92	88	81	75	97
	2.500	89	97	97	93	90	86	80	75	95

## 60 TCNH-B

RPM	SP	SOUND POWER re 10 <sup>-12</sup> WATTS								
		OCTAVE BANDS								L <sub>wi</sub> A
		1	2	3	4	5	6	7	8	
2400	1.000	77	83	82	80	77	72	68	61	82
2600	1.000	77	84	85	83	79	75	70	64	84
	1.250	79	85	85	82	80	75	70	64	85
2800	1.000	77	85	87	85	81	76	72	67	86
	1.250	79	86	87	85	81	77	72	67	87
	1.500	81	88	88	85	82	77	72	67	87
3000	1.000	78	86	89	88	82	78	74	70	88
	1.500	80	88	90	87	84	79	74	69	89
3200	1.000	78	87	90	89	84	80	76	72	90
	1.500	81	89	91	88	85	81	76	72	90
3400	2.000	83	92	92	88	86	82	76	71	91
	1.000	81	89	92	91	87	83	78	74	92
	1.500	81	89	93	90	87	82	77	74	92
3600	2.000	83	91	93	90	88	83	77	73	93
	1.000	83	91	94	93	90	86	80	75	95
	1.500	81	90	94	92	89	84	79	75	94
3800	2.500	85	93	96	92	90	85	79	75	95
	1.000	85	94	96	94	93	88	82	77	97
	1.500	81	90	95	94	90	85	81	77	95
4000	2.500	85	93	97	94	91	86	81	76	96
	1.250	85	93	97	96	93	89	83	78	98
	2.000	83	92	96	96	92	87	82	78	97
	3.000	87	95	98	96	93	88	83	78	98

## 70 TCNH-B

RPM	SP	SOUND POWER re 10 <sup>-12</sup> WATTS								
		OCTAVE BANDS								L <sub>wi</sub> A
		1	2	3	4	5	6	7	8	
2300	1.000	86	87	81	79	77	72	67	61	82
2500	1.000	90	92	84	82	80	76	70	65	85
2700	1.000	93	97	87	85	83	79	72	68	88
	1.250	90	95	87	84	82	78	72	66	87
2900	1.000	96	101	90	87	85	81	74	70	91
	1.250	93	99	89	86	85	81	74	69	90
3100	1.500	91	97	89	86	84	80	74	68	89
	1.000	98	106	92	89	88	84	77	72	94
3300	1.500	94	102	92	88	87	83	76	71	92
	1.000	99	108	95	91	90	86	79	73	96
3500	1.500	96	105	94	90	89	85	78	73	95
	2.000	93	101	94	89	88	84	78	72	93
	1.000	100	109	98	93	91	88	81	75	98
3700	1.500	99	107	97	92	91	87	80	75	97
	2.000	95	104	96	91	90	86	80	74	96
	1.000	101	110	101	95	93	90	83	77	100
3900	1.500	101	109	100	94	92	89	82	76	99
	2.000	98	106	99	93	92	88	82	76	98
	2.500	95	103	98	93	91	87	81	76	97
3900	1.000	102	110	104	97	95	92	85	79	102
	1.500	102	111	103	96	94	91	84	78	101
	2.000	100	108	102	96	93	90	84	78	100
	2.500	97	106	101	95	93	89	83	77	99

The sound power level ratings shown are in decibels referred to 10<sup>-12</sup> watts calculated per AMCA Standard 301. The A-weighted sound ratings shown have been calculated per AMCA Standard 301. Values shown are for inlet L<sub>wi</sub> and inlet L<sub>wi</sub>A sound power levels for Installation Type B: free inlet, ducted outlet.

**80 TCN-B**

RPM	SP	SOUND POWER re 10 <sup>-12</sup> WATTS								
		OCTAVE BANDS								L <sub>wiA</sub>
		1	2	3	4	5	6	7	8	
900	0.000	59	56	55	55	49	44	37	30	55
1100	0.000	64	63	61	60	56	50	43	36	61
1300	0.000	69	69	66	65	61	55	49	42	66
	0.250	67	67	63	62	59	54	49	42	64
1700	0.000	75	78	73	72	70	63	57	50	74
	0.250	74	78	72	71	68	62	57	50	73
	0.500	73	75	71	70	67	62	57	50	72
2100	0.000	79	83	81	78	76	70	64	57	80
	0.500	77	82	80	77	74	69	63	57	79
	0.750	77	81	78	76	73	69	63	57	78
2500	0.000	82	88	87	83	80	76	69	63	86
	0.500	81	88	87	82	79	75	68	62	85
	1.000	80	86	85	81	78	74	68	62	83
2900	0.000	84	92	93	88	84	81	74	67	90
	0.750	83	91	92	86	83	79	73	67	89
	1.500	82	90	89	85	82	78	73	67	88
3300	0.000	87	95	97	91	88	85	78	71	94
	1.000	85	94	97	89	87	83	76	71	93
	2.000	85	93	94	88	85	82	76	71	91
3700	0.500	90	99	100	95	91	87	81	75	97
	0.750	90	99	100	94	90	87	80	75	97
	1.000	89	97	100	94	90	87	80	75	97
	1.250	87	96	100	94	90	86	80	75	96

**100 TCN-B**

RPM	SP	SOUND POWER re 10 <sup>-12</sup> WATTS								
		OCTAVE BANDS								L <sub>wiA</sub>
		1	2	3	4	5	6	7	8	
800	0.000	50	50	49	48	49	45	36	26	52
1000	0.000	57	57	55	54	54	51	44	34	58
1200	0.000	63	62	61	59	58	56	50	40	63
	0.250	61	61	59	57	53	50	47	39	59
1400	0.000	67	67	66	63	61	61	56	46	67
	0.250	65	66	65	62	58	55	53	45	64
1800	0.000	73	74	73	70	68	67	64	55	74
	0.250	71	74	72	69	66	63	61	53	72
	0.500	71	73	71	69	65	61	59	52	71
2200	0.000	77	80	79	76	73	72	69	62	79
	0.500	74	79	78	75	71	67	65	60	77
	0.750	74	79	77	75	71	66	64	59	77
2600	0.000	80	85	84	82	77	75	74	68	84
	0.750	77	83	83	81	76	72	68	65	82
	1.250	78	84	82	79	75	70	67	64	81
3000	0.000	82	90	88	86	81	78	78	73	88
	0.250	81	89	88	86	81	78	76	72	87
	0.500	80	88	88	85	81	77	74	71	87
	1.000	79	87	88	85	80	76	72	70	86
	1.750	80	88	87	83	80	74	70	69	85
3400	0.500	83	91	91	88	84	81	78	75	90
	0.750	82	90	91	88	84	80	77	75	90
	1.000	82	90	91	88	84	80	76	74	90
	1.250	81	90	91	88	84	80	75	74	90

**80 TCNH-B**

RPM	SP	SOUND POWER re 10 <sup>-12</sup> WATTS								
		OCTAVE BANDS								L <sub>wiA</sub>
		1	2	3	4	5	6	7	8	
2300	1.000	75	80	81	79	77	73	67	60	82
2500	1.000	77	83	84	82	80	75	70	63	84
2700	1.000	78	85	86	84	82	78	72	66	87
	1.250	78	85	86	84	82	78	72	66	86
2900	1.000	80	88	89	87	84	81	74	68	89
	1.250	79	87	88	86	84	80	74	68	89
	1.500	79	87	88	86	84	80	74	68	88
3100	1.000	82	90	91	88	86	83	77	70	91
	1.500	80	89	91	88	86	82	77	70	90
	1.750	80	88	90	88	85	81	77	70	90
3300	1.000	83	91	93	90	88	85	79	72	93
	1.500	82	90	92	90	88	84	78	72	92
	2.000	81	89	92	89	87	83	78	72	92
3500	1.000	84	92	95	92	90	87	81	74	95
	1.500	83	92	94	92	89	86	80	74	94
	2.000	82	91	94	91	89	85	80	74	94
3700	1.000	85	93	97	94	92	88	82	76	96
	1.500	84	93	96	94	91	88	82	76	96
	2.000	84	92	95	93	91	87	82	76	96
	2.500	83	91	95	93	90	87	82	76	95
3900	1.000	86	94	98	96	93	90	84	78	98
	1.500	86	94	97	95	93	89	84	77	98
	2.000	85	93	97	95	92	89	84	77	97
	3.000	84	92	96	94	92	88	83	77	97

**100 TCNH-B**

RPM	SP	SOUND POWER re 10 <sup>-12</sup> WATTS								
		OCTAVE BANDS								L <sub>wiA</sub>
		1	2	3	4	5	6	7	8	
2400	1.000	74	80	81	78	74	71	68	62	80
2600	1.000	75	82	83	81	76	73	70	65	83
	1.250	75	82	83	81	76	73	70	65	82
2800	1.000	76	84	86	84	78	75	72	68	85
	1.250	76	84	86	83	78	75	72	67	85
	1.500	77	84	86	83	78	75	73	67	84
3000	1.000	77	85	88	86	81	77	74	70	87
	1.500	78	86	88	85	80	76	74	70	87
3200	1.000	78	86	90	87	82	79	75	72	89
	1.500	79	87	90	87	82	78	76	72	88
	2.000	79	87	90	86	82	78	76	71	88
3400	1.000	79	87	91	89	84	81	78	74	91
	1.500	80	88	91	89	84	80	77	74	90
	2.000	80	88	91	88	84	80	78	73	90
3600	1.000	80	88	92	91	86	82	79	76	92
	1.500	80	89	92	91	86	82	79	75	92
	2.500	81	89	93	90	85	81	79	75	91
3800	1.000	81	89	94	93	88	84	81	78	94
	1.500	81	89	94	92	88	84	80	77	94
	2.000	82	90	94	92	88	83	80	77	93
	2.500	82	90	94	92	87	83	80	76	93
	3.000	82	90	95	94	90	85	83	79	95
4000	1.500	82	90	95	94	90	85	82	78	95
	2.000	82	91	95	94	89	85	81	78	95
	3.000	83	91	95	93	89	84	82	78	95

The sound power level ratings shown are in decibels referred to 10<sup>-12</sup> watts calculated per AMCA Standard 301. The A-weighted sound ratings shown have been calculated per AMCA Standard 301. Values shown are for inlet L<sub>wi</sub> and inlet L<sub>wiA</sub> sound power levels for Installation Type B: free inlet, ducted outlet.

# TCN-B/TCNH-B Sound Data

## 120 TCN-B

RPM	SP	SOUND POWER re 10 <sup>-12</sup> WATTS								
		OCTAVE BANDS								L <sub>wi</sub> A
		1	2	3	4	5	6	7	8	
800	0.000	56	58	58	53	54	52	42	31	58
1000	0.000	65	64	64	60	58	57	50	39	64
	0.250	64	62	63	59	57	55	47	38	62
1200	0.000	72	69	69	66	63	62	57	46	69
	0.250	72	68	69	65	61	60	55	45	68
1400	0.000	78	73	74	71	66	66	63	52	73
	0.250	78	72	73	70	65	64	61	51	72
	0.500	78	71	72	70	64	64	59	50	72
1800	0.000	85	81	80	79	73	72	70	61	80
	0.500	84	80	80	78	72	70	68	60	79
2200	1.000	85	80	78	77	71	70	66	58	78
	0.000	88	89	85	84	79	76	75	69	86
2600	0.750	88	89	85	84	78	74	73	67	85
	1.500	88	88	83	83	78	74	72	65	84
	0.000	91	96	90	89	85	80	79	75	91
3000	0.750	91	96	89	89	84	79	77	74	90
	1.250	91	95	88	88	84	78	77	73	90
	2.000	91	95	88	88	83	78	77	71	89
3600	0.500	94	101	93	93	89	82	82	80	95
	0.750	94	102	93	93	89	82	81	80	95

## 135 TCN-B

RPM	SP	SOUND POWER re 10 <sup>-12</sup> WATTS								
		OCTAVE BANDS								L <sub>wi</sub> A
		1	2	3	4	5	6	7	8	
600	0.000	52	54	54	50	49	43	33	23	53
700	0.000	56	57	60	54	53	49	39	29	57
800	0.000	60	60	64	57	56	53	44	34	61
900	0.000	62	64	66	61	59	56	48	38	64
	0.250	60	61	64	58	56	52	45	37	61
1100	0.000	67	69	70	68	63	62	55	45	70
	0.500	67	65	67	64	59	57	51	44	66
1300	0.000	70	74	74	74	67	66	61	51	74
	0.500	70	71	71	71	64	63	57	49	72
1500	0.000	74	78	77	79	71	70	66	56	79
	0.500	73	76	75	77	68	68	62	54	77
	0.750	75	75	74	76	67	67	61	54	76
1700	0.000	76	81	80	81	75	73	70	61	82
	0.750	75	79	78	79	72	71	66	58	80
	1.250	81	78	76	78	70	69	65	58	78
1900	0.000	78	83	83	84	79	75	73	65	85
	1.000	77	81	81	81	76	73	69	62	82
	1.500	82	82	79	80	74	71	68	61	81
2100	0.000	80	85	86	86	82	78	75	69	87
	1.000	79	84	84	84	80	75	72	65	85
	1.750	83	85	82	82	78	74	71	65	84
2300	0.250	81	87	88	87	85	79	77	71	89
	1.000	80	86	87	86	83	78	75	68	88
	1.500	81	86	86	85	83	77	75	68	87

## 120 TCNH-B

RPM	SP	SOUND POWER re 10 <sup>-12</sup> WATTS								
		OCTAVE BANDS								L <sub>wi</sub> A
		1	2	3	4	5	6	7	8	
1800	1.000	83	80	80	78	72	68	65	58	79
2000	1.000	85	84	83	82	75	71	68	62	82
	1.250	85	84	82	81	75	71	68	61	82
2200	1.000	86	88	86	85	79	74	71	66	86
	1.500	86	88	85	84	78	73	70	64	85
2400	1.000	88	91	88	87	82	77	74	69	88
	1.750	88	91	87	86	81	76	73	67	87
2600	1.000	89	94	90	90	84	79	76	72	91
	2.000	89	94	89	89	84	78	75	70	90
2800	1.000	90	97	92	92	87	81	78	74	93
	2.500	90	97	91	90	86	79	77	72	92
3000	1.000	92	99	93	94	89	83	80	77	95
	2.000	92	99	93	94	89	82	79	76	95
3200	3.000	92	99	92	92	88	81	79	74	94
	1.000	93	101	95	95	91	85	82	79	97
3400	2.000	93	101	96	96	91	84	81	78	97
	3.000	93	101	95	94	90	83	81	77	96
	1.000	94	102	98	97	93	87	84	81	98
3600	2.000	94	102	98	97	93	86	83	80	98
	3.000	94	102	97	96	93	85	82	79	98
	3.500	94	102	97	96	92	85	82	78	97
3600	1.000	95	103	100	98	95	88	85	82	100
	2.000	95	103	100	98	95	88	85	82	100
	3.000	95	103	100	98	95	88	84	81	100
	4.000	95	103	99	97	94	87	83	80	99

## 135 TCNH-B

RPM	SP	SOUND POWER re 10 <sup>-12</sup> WATTS								
		OCTAVE BANDS								L <sub>wi</sub> A
		1	2	3	4	5	6	7	8	
1600	1.000	76	79	77	78	70	69	65	57	78
1800	1.000	77	82	81	81	75	72	69	61	82
	1.250	78	82	81	80	74	72	68	61	81
2000	1.000	79	85	85	84	79	76	72	65	85
	1.250	79	85	85	84	79	75	72	65	85
	1.500	79	85	84	83	78	74	71	65	84
2200	1.000	81	87	88	86	83	78	75	69	88
	1.500	81	87	87	86	82	77	74	68	87
	2.000	81	87	86	85	81	76	73	67	86
2400	1.000	83	89	90	88	86	81	78	72	91
	1.500	82	89	90	88	85	80	77	71	90
	2.000	82	89	90	87	84	79	76	71	89
2600	1.000	85	91	92	90	89	83	81	75	93
	1.500	84	91	92	90	88	82	80	74	93
	2.000	83	90	92	90	88	81	79	74	92
2800	2.500	84	91	92	89	87	80	78	73	91
	1.000	86	93	95	92	91	85	83	78	95
	1.500	86	93	95	92	91	84	83	77	95
	2.000	85	92	95	92	91	83	82	76	95
	2.500	85	92	94	91	90	83	81	76	94
3.000	85	92	94	90	89	82	80	76	93	

The sound power level ratings shown are in decibels referred to 10<sup>-12</sup> watts calculated per AMCA Standard 301. The A-weighted sound ratings shown have been calculated per AMCA Standard 301. Values shown are for inlet L<sub>wi</sub> and inlet L<sub>wi</sub>A sound power levels for Installation Type B: free inlet, ducted outlet.

**150 TCN-B**

RPM	SP	SOUND POWER re 10 <sup>-12</sup> WATTS								
		OCTAVE BANDS								
		1	2	3	4	5	6	7	8	L <sub>wi</sub> A
600	0.000	55	56	56	54	56	50	38	26	59
700	0.000	60	59	62	56	61	56	44	32	63
800	0.000	63	62	65	59	64	60	49	37	67
	0.250	59	60	64	57	58	52	44	36	62
1000	0.000	67	69	70	67	67	67	58	46	72
	0.500	64	65	67	64	60	58	51	44	66
1200	0.000	70	75	74	73	70	72	65	53	77
	0.750	69	70	70	70	64	63	57	50	71
1400	0.000	73	80	77	78	72	76	71	59	81
	0.500	71	77	76	78	70	72	65	55	78
	1.000	73	74	73	75	67	67	62	55	75
1600	0.000	75	83	81	82	75	79	76	64	85
	0.750	73	80	79	81	74	75	69	60	82
	1.250	75	78	77	79	71	71	67	59	79
1800	0.000	77	85	84	85	79	81	79	69	87
	1.000	75	82	82	84	78	77	72	64	85
	1.750	78	81	80	81	75	72	69	63	82
2000	0.000	79	87	88	87	83	82	82	73	90
	1.000	78	84	86	86	82	79	76	68	88
	2.000	79	84	83	84	79	76	73	66	85
2200	0.250	81	88	90	89	86	83	83	75	92
	0.500	81	88	89	89	86	82	81	73	91
	0.750	80	87	89	88	86	82	80	73	91

**165 TCN-B**

RPM	SP	SOUND POWER re 10 <sup>-12</sup> WATTS								
		OCTAVE BANDS								
		1	2	3	4	5	6	7	8	L <sub>wi</sub> A
500	0.000	59	59	59	56	52	48	43	37	58
600	0.000	64	65	63	62	57	53	49	43	63
700	0.000	69	70	67	67	61	58	53	47	68
	0.250	67	69	64	66	60	55	49	43	66
900	0.000	74	76	74	74	68	64	60	55	75
	0.500	72	75	71	71	67	63	56	50	72
1100	0.000	77	82	80	78	75	70	66	61	80
	0.750	76	81	78	75	73	68	63	56	78
1300	0.000	80	86	86	82	80	74	71	66	85
	0.500	80	86	85	81	79	73	68	62	84
	1.000	79	85	84	78	78	73	68	62	83
1500	0.000	83	90	90	85	85	78	75	70	89
	0.750	82	90	90	84	84	77	73	67	88
	1.250	81	89	89	82	83	77	73	66	87
1700	0.000	85	93	93	89	88	82	78	74	92
	1.000	84	92	93	88	87	81	76	70	91
	1.750	83	91	92	85	85	81	76	70	90
1900	0.000	87	94	96	92	90	85	81	77	95
	1.000	87	94	96	91	89	84	79	74	94
	2.000	85	93	95	90	88	84	79	73	93
2100	0.500	89	96	99	95	92	88	83	78	97
	0.750	89	96	98	95	92	88	82	77	97
	1.000	89	96	98	95	92	88	82	77	97

**150 TCNH-B**

RPM	SP	SOUND POWER re 10 <sup>-12</sup> WATTS								
		OCTAVE BANDS								
		1	2	3	4	5	6	7	8	L <sub>wi</sub> A
1300	1.000	73	73	71	71	64	62	57	51	72
1500	1.000	70	80	75	78	68	70	63	57	78
	1.250	75	78	74	76	68	67	62	55	76
1700	1.000	72	81	80	81	74	74	68	61	82
	1.250	72	82	79	80	72	72	67	61	81
	1.500	76	82	78	80	72	71	66	60	80
	1.750	79	81	78	79	72	69	65	59	79
1900	1.000	74	83	84	84	79	78	73	66	85
	1.500	74	83	83	83	77	75	71	64	84
	2.000	79	84	82	82	76	72	69	63	82
2100	1.000	76	84	87	87	83	81	77	69	89
	1.500	76	84	87	86	81	78	75	68	87
	2.000	77	85	86	84	80	76	73	67	86
	2.500	81	87	85	84	79	75	72	66	85
2300	1.000	78	86	90	89	86	83	81	73	92
	1.500	77	86	90	88	85	81	79	72	90
	2.000	77	86	89	87	84	79	77	70	89
	2.500	79	87	89	86	83	78	76	70	88
2500	3.000	83	89	88	85	83	77	74	69	88
	1.000	79	87	92	91	89	85	84	76	94
	1.500	79	87	92	91	89	83	83	75	93
	2.000	79	87	92	90	88	82	81	74	92
	2.500	79	87	92	89	87	80	80	73	91
3.000	81	89	92	88	86	79	78	72	91	
	84	91	91	87	86	79	77	71	90	

**165 TCNH-B**

RPM	SP	SOUND POWER re 10 <sup>-12</sup> WATTS								
		OCTAVE BANDS								
		1	2	3	4	5	6	7	8	L <sub>wi</sub> A
1300	1.000	81	87	83	77	77	70	68	62	82
1500	1.000	79	87	89	81	84	75	73	68	87
	1.250	82	90	89	80	82	74	72	67	86
1700	1.000	81	89	92	86	88	79	77	72	91
	1.250	81	89	92	85	87	79	77	72	90
	1.500	84	91	92	85	86	79	76	71	90
	1.750	86	94	92	84	84	78	75	70	89
1900	1.000	83	91	95	91	90	84	79	75	94
	1.500	83	91	94	90	89	83	79	75	93
	1.750	84	92	95	89	88	83	79	75	93
	2.000	86	94	95	89	87	82	78	74	92
2100	1.000	85	93	97	94	92	88	82	78	97
	1.500	85	93	97	94	91	87	82	78	96
	2.000	85	93	97	93	90	87	81	78	96
	2.500	89	96	98	92	89	85	81	77	95
2300	1.000	87	95	100	98	94	91	84	81	99
	1.500	87	94	99	97	93	91	84	81	99
	2.000	86	94	99	97	93	90	84	81	98
	2.500	87	95	99	96	92	90	83	80	98
	3.000	90	98	101	96	91	88	83	80	98

The sound power level ratings shown are in decibels referred to 10<sup>-12</sup> watts calculated per AMCA Standard 301. The A-weighted sound ratings shown have been calculated per AMCA Standard 301. Values shown are for inlet L<sub>wi</sub> and inlet L<sub>wi</sub>A sound power levels for Installation Type B: free inlet, ducted outlet.

# TCN-B/TCNH-B Sound Data

## 180 TCN-B

RPM	SP	SOUND POWER re 10 <sup>-12</sup> WATTS								
		OCTAVE BANDS								L <sub>wiA</sub>
		1	2	3	4	5	6	7	8	
500	0.000	64	63	62	57	52	45	39	33	59
600	0.000	70	68	66	63	57	52	44	38	64
700	0.000	75	73	70	69	61	57	49	43	69
	0.250	74	73	68	67	59	55	48	42	67
800	0.000	78	77	74	73	65	61	53	47	73
	0.250	77	77	73	71	64	59	52	46	72
1000	0.000	82	84	81	78	73	67	61	54	79
	0.500	81	83	80	76	71	65	59	53	78
1200	0.000	85	90	86	83	79	72	67	59	85
	0.500	85	90	86	81	77	71	65	59	84
	0.750	84	89	86	81	77	70	65	59	83
1400	0.000	88	95	91	87	84	76	72	64	89
	0.750	87	94	91	85	83	75	70	63	88
	1.250	85	92	90	84	82	75	70	63	87
1600	0.000	90	98	95	91	88	80	76	68	93
	0.750	90	97	96	90	87	79	75	67	92
	1.500	88	96	94	88	86	79	74	67	91
1800	0.250	92	100	99	94	91	84	79	72	96
	0.500	92	100	99	94	90	84	79	72	96
	1.000	92	99	99	93	90	83	78	71	96
	1.500	91	99	98	93	89	83	77	71	95
	1.750	91	98	98	92	89	83	77	71	95

## 195 TCN-B

RPM	SP	SOUND POWER re 10 <sup>-12</sup> WATTS								
		OCTAVE BANDS								L <sub>wiA</sub>
		1	2	3	4	5	6	7	8	
400	0.000	60	58	59	54	50	42	36	30	56
500	0.000	64	66	65	61	56	49	43	37	62
600	0.000	67	71	69	67	61	56	48	42	68
	0.250	65	71	65	64	58	53	46	41	65
700	0.000	70	76	73	72	65	61	53	47	72
	0.250	68	77	70	70	63	59	51	45	70
800	0.000	73	80	76	76	69	65	57	51	76
	0.500	68	80	72	72	67	62	55	49	73
1000	0.000	76	84	83	81	76	71	65	58	82
	0.500	74	83	82	79	74	69	63	56	80
	0.750	72	82	81	77	73	68	62	56	79
1200	0.000	80	87	89	85	82	76	71	63	87
	0.500	78	86	89	84	80	74	69	62	86
	1.000	75	84	88	82	79	74	68	61	85
1400	0.000	82	90	94	89	87	80	76	68	92
	0.750	81	88	95	87	85	79	74	66	91
	1.500	77	85	94	85	83	78	73	66	89
1600	0.250	84	91	98	92	91	83	80	72	95
	0.500	84	91	98	92	90	82	79	71	95
	1.000	83	90	98	91	89	82	78	70	94

## 180 TCNH-B

RPM	SP	SOUND POWER re 10 <sup>-12</sup> WATTS								
		OCTAVE BANDS								L <sub>wiA</sub>
		1	2	3	4	5	6	7	8	
1500	1.000	82	90	92	86	85	77	72	65	89
1600	1.000	84	91	94	88	87	79	74	67	91
	1.250	83	91	93	88	86	79	74	67	91
1700	1.000	85	93	96	91	88	82	76	69	93
	1.250	85	92	95	90	88	81	76	69	93
1800	1.000	86	94	97	93	90	83	78	71	95
	1.250	86	94	97	92	90	83	77	71	95
	1.500	85	93	96	92	89	83	77	71	94
1900	1.000	87	95	99	95	91	85	79	73	97
	1.500	87	94	98	94	91	85	79	73	96
	1.750	86	94	97	93	90	84	79	73	95
2000	1.000	88	96	100	97	93	87	81	75	98
	1.500	88	95	99	96	92	87	80	74	98
	1.750	87	95	99	95	92	86	80	74	97
2100	1.000	89	96	101	99	94	89	82	76	100
	1.500	89	96	101	98	94	89	82	76	99
	2.000	88	96	100	97	93	88	82	76	98
2200	1.000	90	97	102	100	95	90	84	78	101
	1.500	90	97	102	100	95	90	83	77	101
	2.000	89	97	101	99	94	90	83	77	100
2300	1.000	90	98	103	102	96	92	85	79	102
	1.500	90	98	103	101	96	92	85	79	102
	2.000	90	98	102	101	96	92	85	79	102
	2.500	90	97	102	99	95	91	84	79	101

## 195 TCNH-B

RPM	SP	SOUND POWER re 10 <sup>-12</sup> WATTS								
		OCTAVE BANDS								L <sub>wiA</sub>
		1	2	3	4	5	6	7	8	
1300	1.000	75	83	87	84	82	75	70	62	86
1400	1.000	77	84	90	86	85	78	72	65	89
1500	1.000	78	86	93	88	87	81	75	67	91
	1.250	78	85	92	87	87	80	74	67	90
1600	1.000	80	87	94	89	89	83	77	69	93
	1.250	79	87	94	89	89	83	77	69	93
	1.500	79	86	93	89	88	82	76	68	92
1700	1.000	81	88	95	92	91	85	79	71	95
	1.500	80	88	94	91	90	84	78	71	94
	1.750	80	87	93	90	90	84	78	70	93
1800	1.000	82	89	96	93	92	87	81	74	96
	1.500	81	89	96	93	91	87	80	73	96
	2.000	81	88	94	92	91	85	80	72	95
1900	1.000	83	90	96	95	93	89	83	75	98
	1.500	83	90	97	95	93	89	82	75	97
	2.000	82	89	96	94	92	87	82	74	96
2000	1.000	83	91	97	97	95	90	84	77	99
	1.500	83	91	97	97	94	90	84	77	99
	2.000	83	90	97	96	94	90	83	76	98
2100	1.000	84	92	98	98	96	92	86	79	100
	1.500	84	92	98	98	95	92	86	79	100
	2.000	84	92	98	98	95	91	85	78	100
	2.500	84	91	97	97	94	91	84	78	99

The sound power level ratings shown are in decibels referred to 10<sup>-12</sup> watts calculated per AMCA Standard 301. The A-weighted sound ratings shown have been calculated per AMCA Standard 301. Values shown are for inlet L<sub>wi</sub> and inlet L<sub>wiA</sub> sound power levels for Installation Type B: free inlet, ducted outlet.

**210 TCN-B**

RPM	SP	SOUND POWER re 10 <sup>-12</sup> WATTS								
		OCTAVE BANDS								L <sub>wi</sub> A
		1	2	3	4	5	6	7	8	
400	0.000	60	59	60	55	50	42	37	32	57
500	0.000	64	66	65	62	57	50	43	38	63
600	0.000	68	71	70	68	62	56	48	43	68
	0.250	65	69	67	65	60	54	47	42	66
700	0.000	71	76	73	73	66	61	53	48	73
	0.250	69	74	72	71	65	60	52	47	71
800	0.000	73	79	77	76	70	66	57	52	77
	0.500	70	77	75	73	68	63	56	50	74
900	0.000	75	81	80	79	74	69	61	55	80
	0.500	73	80	79	77	72	67	60	54	78
1000	0.000	77	83	83	82	77	72	65	58	83
	0.750	74	81	81	79	75	70	63	57	80
1100	0.000	79	85	86	84	80	75	68	61	85
	0.500	78	84	85	83	79	73	67	60	84
	1.000	75	83	84	81	77	72	66	60	83
1200	0.000	80	87	89	86	83	77	71	63	88
	0.500	80	87	88	85	82	76	70	63	87
	0.750	79	85	87	84	81	76	70	63	86
1300	1.250	76	84	87	83	79	75	69	62	85
	0.000	81	88	91	88	86	79	74	66	90
	0.500	82	89	91	87	85	79	73	65	89
	0.750	81	87	90	87	84	78	72	65	89
1400	1.500	78	85	89	85	82	77	72	65	87
	0.250	83	90	94	90	87	81	76	68	92
0.750	82	89	92	89	86	80	75	67	91	

**225 TCN-B**

RPM	SP	SOUND POWER re 10 <sup>-12</sup> WATTS								
		OCTAVE BANDS								L <sub>wi</sub> A
		1	2	3	4	5	6	7	8	
400	0.000	58	61	59	57	54	47	41	35	59
500	0.000	63	66	65	63	60	54	48	42	65
600	0.000	67	70	70	67	64	60	53	47	70
	0.250	66	70	70	67	63	58	51	44	68
700	0.000	70	74	74	72	69	65	58	52	74
	0.500	68	73	73	70	66	61	55	48	72
800	0.000	73	77	78	75	72	69	62	56	77
	0.750	71	75	76	73	69	65	59	53	75
900	0.000	75	79	81	78	75	72	66	60	80
	0.750	73	78	80	77	73	69	63	56	79
1000	0.000	77	82	83	81	78	75	69	63	83
	0.500	76	83	84	81	77	74	68	60	83
	1.000	75	80	82	80	76	72	66	59	81
1100	0.000	78	84	85	84	80	77	72	66	86
	0.750	77	84	86	83	80	76	70	63	85
	1.250	76	82	84	82	79	74	69	62	84
1200	0.000	80	85	87	86	83	80	75	68	88
	0.750	79	86	88	86	82	79	74	66	88
	1.500	78	84	86	85	81	77	72	65	86
1300	0.000	81	87	89	88	85	82	78	71	90
	1.000	80	87	90	88	84	80	76	69	90
	2.000	79	85	87	87	83	79	73	67	88
1500	0.250	84	90	93	92	89	85	82	75	94
	1.250	83	90	94	92	88	84	81	73	94
	2.500	82	88	91	91	87	83	78	72	92

**210 TCNH-B**

RPM	SP	SOUND POWER re 10 <sup>-12</sup> WATTS								
		OCTAVE BANDS								L <sub>wi</sub> A
		1	2	3	4	5	6	7	8	
1100	1.000	77	84	85	80	77	72	65	58	83
1200	1.000	79	86	88	83	80	75	69	61	86
	1.250	78	86	88	83	80	75	67	61	85
1300	1.000	80	88	91	86	83	78	72	63	88
	1.250	80	87	91	85	82	78	71	63	88
	1.500	80	87	91	85	82	77	70	63	87
1400	1.000	82	89	93	88	85	80	76	66	91
	1.250	81	89	93	88	85	80	75	66	90
	1.500	81	88	93	87	84	80	73	65	90
1500	1.000	83	90	96	90	87	82	79	68	93
	1.500	83	90	96	89	86	82	77	68	92
	1.750	82	90	96	89	86	82	75	67	92
	2.000	82	89	96	88	85	82	74	67	92
1600	1.000	84	91	97	92	89	84	81	71	95
	1.500	84	91	97	92	88	84	79	70	94
	1.750	84	91	97	91	88	84	78	70	94
	2.000	83	91	97	91	88	84	77	69	94
1700	1.000	85	92	98	94	91	86	83	73	96
	1.500	85	92	98	94	90	86	82	72	96
	1.750	85	92	98	94	90	86	81	72	96
	2.000	85	92	98	93	90	86	80	72	95
	2.500	84	92	98	93	89	86	79	71	95

**225 TCNH-B**

RPM	SP	SOUND POWER re 10 <sup>-12</sup> WATTS								
		OCTAVE BANDS								L <sub>wi</sub> A
		1	2	3	4	5	6	7	8	
900	1.000	71	78	79	76	72	65	59	52	77
1000	1.000	73	80	83	80	75	69	63	56	81
	1.250	73	80	81	78	74	68	62	55	80
1100	1.000	75	82	86	84	78	73	66	59	84
	1.250	75	82	85	82	78	72	66	59	83
	1.500	74	82	84	81	77	71	65	59	82
1200	1.000	76	83	87	86	81	76	70	62	87
	1.500	76	83	87	85	80	75	68	62	86
	1.750	76	83	87	84	80	74	67	61	85
1300	1.000	77	84	89	88	83	79	73	65	89
	1.500	78	85	89	88	83	78	72	65	89
	2.000	77	84	89	86	82	77	70	64	87
1400	1.000	79	85	91	90	85	81	75	68	91
	1.500	79	86	91	91	85	81	74	67	91
	2.000	79	86	91	90	85	80	73	67	90
1500	1.000	80	86	92	92	87	83	78	70	93
	1.500	80	87	92	93	87	83	77	70	93
	2.000	81	87	92	93	87	82	76	69	93
	2.500	80	87	93	91	86	82	75	69	92
1600	1.500	81	88	94	94	89	85	79	72	95
	2.000	82	88	94	95	89	84	79	71	95
	2.500	81	88	94	94	89	84	77	71	94
3.000	81	88	94	92	88	84	76	71	93	

The sound power level ratings shown are in decibels referred to 10<sup>-12</sup> watts calculated per AMCA Standard 301. The A-weighted sound ratings shown have been calculated per AMCA Standard 301. Values shown are for inlet L<sub>wi</sub> and inlet L<sub>wi</sub>A sound power levels for Installation Type B: free inlet, ducted outlet.



# TCN-B/TCNH-B Sound Data

## 245 TCN-B

RPM	SP	SOUND POWER re 10 <sup>-12</sup> WATTS								
		OCTAVE BANDS								L <sub>wi</sub> A
		1	2	3	4	5	6	7	8	
400	0.000	64	66	63	61	57	50	42	34	62
500	0.000	67	72	70	67	63	57	50	42	68
	0.250	64	69	68	65	60	55	47	39	66
600	0.000	69	76	75	71	68	63	56	48	73
	0.500	67	72	72	68	64	60	53	45	70
700	0.000	71	80	79	75	72	68	61	53	78
	0.750	71	75	75	72	68	64	58	50	74
800	0.000	73	83	83	79	76	72	65	57	81
	0.500	72	80	82	78	75	70	63	55	80
	1.000	73	78	79	76	72	68	62	54	78
900	0.000	75	84	86	82	79	75	69	61	85
	0.750	74	82	84	81	77	73	67	59	83
	1.250	75	80	82	79	75	71	66	58	81
1000	0.000	77	86	89	85	82	78	72	65	87
	0.750	76	84	87	84	81	76	70	63	86
	1.500	77	82	84	82	78	74	69	62	84
1100	0.000	79	87	91	88	84	81	75	68	90
	1.000	78	85	89	87	83	79	73	66	88
	1.750	78	84	87	85	81	77	72	65	87
1300	0.000	82	89	96	93	89	85	81	74	95
	1.000	81	88	93	92	88	85	79	72	94
	2.500	81	88	90	90	86	82	77	71	91
1500	0.500	84	91	98	97	92	89	85	78	98
	1.000	84	90	97	97	92	89	84	77	98
	1.500	83	90	96	96	92	89	83	76	97

## 270 TCN-B

RPM	SP	SOUND POWER re 10 <sup>-12</sup> WATTS								
		OCTAVE BANDS								L <sub>wi</sub> A
		1	2	3	4	5	6	7	8	
350	0.000	61	62	56	55	51	45	38	31	56
450	0.000	66	69	64	61	58	53	46	39	63
	0.250	65	67	62	58	56	51	45	39	61
550	0.000	70	74	71	66	64	59	52	45	69
	0.500	67	71	67	63	60	57	51	46	66
650	0.000	73	78	76	71	68	64	58	51	74
	0.750	69	74	72	67	64	62	56	50	70
750	0.000	75	82	81	74	72	68	62	55	78
	0.500	73	80	80	72	70	67	60	54	76
	1.000	72	78	76	71	68	66	61	55	74
850	0.000	77	84	84	78	75	72	66	59	81
	0.750	75	83	83	76	73	70	64	58	80
	1.250	74	80	80	75	71	69	64	58	78
950	0.000	79	86	87	82	78	75	69	63	84
	0.750	77	84	86	81	76	74	68	61	83
	1.500	76	83	84	78	74	72	67	62	81
1050	0.000	81	88	90	85	80	77	72	66	87
	1.000	79	86	88	84	78	76	71	64	86
	2.000	78	84	85	81	77	74	70	65	83
1150	0.000	82	89	92	88	83	80	75	69	90
	1.000	81	87	91	87	81	79	74	67	88
	2.000	79	87	91	85	79	77	73	67	87
1250	0.500	83	90	93	91	84	82	77	71	92
	1.000	82	89	92	90	83	81	77	70	91
	2.000	81	88	94	89	82	80	76	70	90

## 245 TCNH-B

RPM	SP	SOUND POWER re 10 <sup>-12</sup> WATTS								
		OCTAVE BANDS								L <sub>wi</sub> A
		1	2	3	4	5	6	7	8	
800	1.000	72	78	79	75	71	66	59	51	77
900	1.000	74	81	83	79	76	71	63	55	81
	1.250	74	81	82	79	74	70	63	55	80
1000	1.000	76	83	86	83	79	74	67	59	85
	1.250	76	83	85	83	78	74	67	59	84
1000	1.500	76	83	85	82	77	73	66	59	83
	1.000	78	85	89	86	82	78	71	63	88
1100	1.500	78	85	88	85	81	77	70	62	87
	1.750	78	84	87	85	80	76	70	62	86
	1.000	79	87	92	89	84	80	74	66	90
1200	1.500	79	86	90	89	84	80	73	65	90
	2.000	79	86	89	87	83	79	73	65	89
	1.000	81	88	94	92	87	83	77	69	93
1300	1.500	81	88	93	91	86	83	76	68	92
	2.000	81	88	92	91	86	82	76	68	91
	2.500	81	87	91	89	85	81	75	68	90
1400	1.000	82	89	95	94	89	85	80	71	95
	2.000	82	89	94	93	88	85	78	70	94
	2.500	82	89	93	92	87	84	78	70	93
	3.000	82	89	93	91	87	83	77	70	92
1500	1.000	83	90	96	96	91	88	82	74	97
	2.000	83	90	96	96	90	87	81	73	96
	2.500	83	90	95	95	89	86	80	72	96
	3.000	83	90	95	94	89	85	80	72	95
	3.500	83	90	94	93	88	84	79	72	94

## 270 TCNH-B

RPM	SP	SOUND POWER re 10 <sup>-12</sup> WATTS								
		OCTAVE BANDS								L <sub>wi</sub> A
		1	2	3	4	5	6	7	8	
750	1.000	79	77	80	70	67	63	57	53	75
850	1.000	81	82	84	76	72	67	60	56	79
	1.250	81	81	83	75	70	66	61	57	78
950	1.000	83	85	86	81	75	71	65	59	83
	1.250	83	85	86	80	74	70	64	59	82
	1.500	83	85	85	79	73	69	64	60	81
1050	1.000	84	88	88	85	78	75	69	62	86
	1.500	85	88	88	84	77	73	67	62	85
	2.000	85	88	87	83	75	72	67	63	84
1150	1.000	85	90	90	88	81	78	73	65	89
	1.500	86	90	90	88	80	77	71	65	88
	2.000	87	91	90	87	79	75	70	64	87
1250	1.000	86	92	92	91	84	81	76	68	91
	1.500	87	92	92	91	83	80	75	67	91
	2.000	88	93	92	91	82	79	73	67	91
	2.500	88	93	91	90	81	77	72	67	90
1350	1.250	87	94	94	94	86	83	79	70	94
	1.500	88	94	94	94	85	82	78	70	93
	2.000	89	95	93	94	85	81	77	69	93
	2.500	89	95	93	93	84	81	75	69	93
	3.000	89	95	93	93	83	79	75	69	92

The sound power level ratings shown are in decibels referred to 10<sup>-12</sup> watts calculated per AMCA Standard 301. The A-weighted sound ratings shown have been calculated per AMCA Standard 301. Values shown are for inlet L<sub>wi</sub> and inlet L<sub>wi</sub>A sound power levels for Installation Type B: free inlet, ducted outlet.

**300 TCN-B**

RPM	SP	SOUND POWER re 10 <sup>-12</sup> WATTS								
		OCTAVE BANDS								L <sub>wi</sub> A
		1	2	3	4	5	6	7	8	
300	0.000	62	62	59	60	53	46	40	34	60
400	0.000	67	70	67	66	62	55	48	42	67
	0.250	66	68	65	63	58	52	46	40	64
500	0.000	72	75	74	71	69	62	55	49	73
	0.500	70	74	70	67	64	58	52	46	69
600	0.000	75	80	79	75	75	68	61	55	78
	0.500	74	79	77	73	71	65	58	52	76
700	0.000	78	83	83	79	78	73	66	59	82
	0.500	77	83	82	77	76	70	63	57	80
	1.000	76	82	79	75	73	68	63	57	78
800	0.000	80	85	86	83	81	77	70	63	86
	0.750	79	85	85	81	79	74	67	61	84
	1.250	78	84	84	79	77	73	67	61	82
900	0.000	82	88	89	86	84	81	74	67	89
	0.750	81	87	89	85	82	78	71	65	87
	1.500	81	87	87	83	80	76	70	64	85
1000	0.000	84	90	92	89	86	84	77	70	92
	1.000	83	89	91	88	84	81	75	68	90
	1.500	83	89	91	87	83	80	74	67	89
	2.000	82	88	90	86	82	79	73	67	88

**330 TCN-B**

RPM	SP	SOUND POWER re 10 <sup>-12</sup> WATTS								
		OCTAVE BANDS								L <sub>wi</sub> A
		1	2	3	4	5	6	7	8	
300	0.000	70	67	63	62	58	49	42	37	63
400	0.000	76	77	71	69	66	60	50	45	71
	0.250	73	76	70	67	63	57	49	45	69
500	0.000	80	85	77	74	73	68	57	52	77
	0.500	77	83	76	72	69	63	55	52	75
600	0.000	83	88	84	79	77	73	64	57	82
	0.500	81	86	83	78	75	70	62	56	81
	0.750	80	86	82	77	74	69	61	57	80
700	0.000	85	91	89	83	81	78	70	62	86
	0.750	83	89	88	82	79	75	67	60	85
	1.250	81	87	87	81	77	73	66	60	83
800	0.000	88	94	94	86	84	82	75	66	90
	0.500	86	92	93	86	83	80	73	64	90
	1.000	85	91	93	86	82	79	72	64	89
900	1.500	84	90	92	85	81	77	71	64	88
	0.000	90	96	98	90	86	85	79	69	94
	0.500	89	95	97	90	86	84	78	68	93
1000	1.000	88	94	97	89	85	83	76	67	93
	1.500	87	93	96	89	85	82	75	67	92
	2.000	86	92	96	88	84	80	75	67	91

**300 TCNH-B**

RPM	SP	SOUND POWER re 10 <sup>-12</sup> WATTS								
		OCTAVE BANDS								L <sub>wi</sub> A
		1	2	3	4	5	6	7	8	
700	1.000	77	80	79	75	72	66	60	53	77
750	1.000	78	82	81	78	75	69	62	56	80
800	1.000	79	83	83	80	77	71	65	58	82
	1.250	79	83	82	79	76	70	64	58	81
850	1.000	80	85	85	82	79	74	67	60	84
	1.500	80	84	84	81	77	72	66	60	82
900	1.000	81	86	87	84	81	76	69	61	86
	1.500	81	86	86	83	79	75	68	61	85
	1.750	81	85	85	82	79	74	68	61	84
950	1.000	82	87	89	86	83	78	70	63	88
	1.500	82	87	88	85	81	77	70	63	87
	1.750	82	87	87	84	81	76	69	63	86
1000	1.000	83	88	90	88	84	80	72	65	90
	1.500	83	88	89	87	83	79	71	65	88
	2.000	83	88	88	85	82	78	71	65	87
1100	1.000	85	90	92	91	87	84	76	68	92
	1.500	85	90	92	90	86	83	75	68	92
	2.000	85	90	92	89	85	82	74	68	91
	2.500	85	90	91	88	84	80	74	68	90
1200	1.250	86	92	94	93	89	87	79	71	95
	1.500	86	92	94	93	89	86	78	71	94
	2.000	86	92	94	92	88	85	77	71	94
	2.500	86	92	94	91	87	84	77	71	93
	3.000	86	92	93	90	86	83	76	71	92

**330 TCNH-B**

RPM	SP	SOUND POWER re 10 <sup>-12</sup> WATTS								
		OCTAVE BANDS								L <sub>wi</sub> A
		1	2	3	4	5	6	7	8	
650	1.000	85	90	86	79	75	69	62	55	82
700	1.000	87	92	89	82	77	72	64	57	85
	1.250	86	92	89	81	77	71	64	57	84
750	1.000	88	94	92	84	80	75	67	59	88
	1.250	87	93	92	83	79	74	67	59	87
800	1.000	90	96	95	86	82	77	70	61	90
	1.250	89	95	94	86	81	76	69	61	89
	1.500	88	94	94	85	81	76	69	61	89
850	1.000	91	97	97	88	84	79	72	63	92
	1.500	90	96	96	87	83	78	71	63	91
	1.750	89	95	96	86	82	78	71	63	91
900	1.000	92	98	99	90	86	82	74	65	94
	1.500	91	97	99	89	85	80	73	65	93
	2.000	90	96	98	88	84	79	73	65	93
1000	1.000	95	100	103	94	89	85	78	68	97
	1.500	94	100	103	93	88	84	77	68	97
	2.000	93	99	102	92	87	83	76	68	96
	2.500	92	98	102	91	87	82	76	68	96
1100	1.000	96	102	105	97	92	88	82	72	100
	1.500	96	102	105	97	91	87	81	72	100
	2.000	95	101	104	96	91	87	80	72	99
	3.000	94	100	104	95	90	85	79	71	98

The sound power level ratings shown are in decibels referred to 10<sup>-12</sup> watts calculated per AMCA Standard 301. The A-weighted sound ratings shown have been calculated per AMCA Standard 301. Values shown are for inlet L<sub>wi</sub> and inlet L<sub>wi</sub>A sound power levels for Installation Type B: free inlet, ducted outlet.

# TCN-B/TCNH-B Sound Data

## 365 TCN-B

RPM	SP	SOUND POWER re 10 <sup>-12</sup> WATTS								
		OCTAVE BANDS								L <sub>wi</sub> A
		1	2	3	4	5	6	7	8	
250	0.000	67	67	64	59	53	45	39	34	61
300	0.000	71	73	69	65	59	51	44	39	66
350	0.000	74	78	73	70	63	56	49	44	71
	0.250	73	80	73	69	62	55	48	44	71
400	0.000	76	81	77	73	68	61	53	48	75
	0.250	75	84	77	74	67	59	52	48	75
450	0.000	78	83	80	77	71	64	57	51	78
	0.500	77	85	81	76	70	63	56	50	78
500	0.000	80	85	83	79	74	68	60	54	81
	0.500	79	86	85	79	74	66	59	54	81
550	0.000	81	87	86	82	77	71	63	57	84
	0.750	81	87	88	82	76	69	62	56	84
600	0.000	83	88	89	84	80	74	66	59	86
	0.750	82	89	91	84	79	72	65	59	86
650	0.000	84	90	91	86	82	76	69	62	88
	1.000	83	90	93	86	82	75	67	61	89
700	0.000	86	91	94	88	85	79	71	64	90
	0.750	85	91	96	88	85	78	70	63	91
	1.250	85	91	96	88	84	77	70	63	91
750	0.000	87	93	96	90	87	81	74	66	92
	0.750	86	92	98	90	87	80	72	65	93
	1.250	86	92	98	90	86	79	72	65	93
800	0.250	88	94	98	92	89	83	75	68	95
	1.000	87	93	100	92	89	82	74	67	95
	1.500	87	93	99	92	88	81	74	67	95

## 365 TCNH-B

RPM	SP	SOUND POWER re 10 <sup>-12</sup> WATTS								
		OCTAVE BANDS								L <sub>wi</sub> A
		1	2	3	4	5	6	7	8	
550	1.000	78	83	82	78	75	68	61	55	80
600	1.000	81	86	86	81	78	71	64	58	83
	1.250	79	85	84	80	77	70	64	58	82
650	1.000	83	89	89	84	81	74	67	60	86
	1.250	82	88	88	83	81	73	67	60	85
700	1.000	85	90	91	86	83	76	69	62	88
	1.250	85	90	91	86	83	76	69	63	88
	1.500	83	89	90	84	83	75	69	62	87
750	1.000	86	92	93	87	86	79	71	64	90
	1.500	86	92	93	87	86	78	72	65	90
	1.750	84	90	92	86	85	77	71	64	89
800	1.000	87	93	94	89	87	81	73	66	92
	1.500	87	93	94	89	87	80	73	66	92
	2.000	85	91	94	88	87	79	73	66	91
900	1.000	89	95	97	93	90	85	77	70	95
	1.500	89	95	97	93	90	85	77	70	95
	2.000	89	95	97	93	90	84	77	70	95
	2.500	87	93	96	91	89	83	77	70	94
1000	1.250	91	97	99	96	93	88	81	73	98
	1.500	91	97	99	96	93	88	80	73	98
	2.000	91	97	99	96	93	88	80	73	98
	2.500	91	97	99	96	93	87	80	74	98
3.000	89	95	98	95	92	87	80	73	97	

## 402 TCN-B

RPM	SP	SOUND POWER re 10 <sup>-12</sup> WATTS								
		OCTAVE BANDS								L <sub>wi</sub> A
		1	2	3	4	5	6	7	8	
250	0.000	71	70	67	62	56	48	42	37	64
300	0.000	74	76	72	68	62	54	47	42	69
	0.250	74	78	72	67	60	53	46	42	69
350	0.000	77	81	76	73	66	59	52	47	74
	0.250	77	83	76	73	65	58	51	47	74
400	0.000	79	84	80	76	71	64	56	51	78
	0.500	79	86	80	76	69	62	55	50	77
450	0.000	81	86	83	80	74	67	60	54	81
	0.500	81	88	84	79	73	66	59	54	81
500	0.000	83	88	87	82	77	71	63	57	84
	0.500	82	90	88	83	77	69	62	57	84
	0.750	82	89	88	82	76	69	62	56	84
550	0.000	85	90	90	85	80	74	66	60	87
	0.500	84	91	91	85	80	73	65	59	87
	0.750	84	91	91	85	80	72	65	59	87
600	0.000	86	92	92	87	83	77	69	62	89
	0.500	86	92	94	88	83	76	68	62	90
	1.000	86	92	94	87	82	75	68	62	89
650	0.000	88	93	95	89	85	79	72	65	91
	0.750	87	93	97	90	86	78	71	64	92
700	0.250	89	95	98	92	88	82	74	67	94
	0.500	89	95	99	92	89	81	74	67	94

## 402 TCNH-B

RPM	SP	SOUND POWER re 10 <sup>-12</sup> WATTS								
		OCTAVE BANDS								L <sub>wi</sub> A
		1	2	3	4	5	6	7	8	
500	1.000	80	85	82	79	74	68	61	56	80
550	1.000	83	88	86	83	78	71	65	59	84
600	1.000	85	90	89	85	81	74	67	61	87
	1.250	85	89	89	84	81	74	67	61	86
650	1.000	87	92	92	87	84	77	69	63	89
	1.250	87	92	92	87	84	77	70	63	89
	1.500	86	91	91	86	84	76	70	63	88
700	1.000	88	94	94	89	87	80	72	65	91
	1.500	88	94	94	89	86	79	72	66	91
	1.750	87	92	93	88	86	78	72	65	91
750	1.000	90	95	96	90	89	82	74	67	93
	1.500	89	95	96	90	89	81	74	67	93
	2.000	88	94	96	89	88	80	74	67	93
800	1.000	91	96	98	92	90	84	76	69	95
	1.500	90	96	98	92	90	84	76	69	95
	2.000	90	96	98	92	90	83	77	70	95
	2.500	88	94	97	90	90	82	76	69	94
850	1.250	92	97	99	94	92	86	78	71	97
	1.500	92	97	99	94	92	86	78	71	97
	2.000	92	97	99	94	92	85	78	71	97
	2.500	91	96	98	93	91	85	78	71	96

The sound power level ratings shown are in decibels referred to 10<sup>-12</sup> watts calculated per AMCA Standard 301. The A-weighted sound ratings shown have been calculated per AMCA Standard 301. Values shown are for inlet L<sub>wi</sub> and inlet L<sub>wi</sub>A sound power levels for Installation Type B: free inlet, ducted outlet.

**445 TCN-B**

RPM	SP	SOUND POWER re 10 <sup>-12</sup> WATTS								
		OCTAVE BANDS								L <sub>wi</sub> A
		1	2	3	4	5	6	7	8	
200	0.000	70	67	64	59	52	44	39	34	60
250	0.000	74	74	70	65	59	51	45	40	67
300	0.000	78	79	75	71	65	57	50	45	72
	0.250	78	81	75	71	63	56	50	46	72
350	0.000	81	84	79	76	69	62	55	50	77
	0.250	80	86	79	76	69	61	54	50	77
400	0.000	83	88	83	80	74	67	59	54	81
	0.500	82	90	83	79	72	65	58	53	81
450	0.000	85	90	86	83	77	71	63	57	84
	0.750	84	91	87	82	76	69	62	56	84
500	0.000	87	92	90	86	80	74	66	60	87
	0.750	86	93	91	85	80	72	65	60	87
550	0.000	89	94	93	88	83	77	69	63	90
	0.500	88	94	94	88	84	76	69	63	90
	1.000	88	94	94	88	82	75	68	62	90
600	0.000	90	95	95	90	86	80	72	65	92
	0.750	89	96	97	91	86	79	71	65	93
	1.250	89	95	97	90	85	78	71	65	92
650	0.250	91	97	99	93	89	82	75	68	95
	0.500	91	97	99	93	89	82	74	68	95
	1.000	91	97	100	93	88	81	73	67	95
	1.500	91	96	100	92	88	81	73	67	95

**490 TCN-B**

RPM	SP	SOUND POWER re 10 <sup>-12</sup> WATTS								
		OCTAVE BANDS								L <sub>wi</sub> A
		1	2	3	4	5	6	7	8	
175	0.000	70	66	63	57	50	43	38	33	59
225	0.000	76	74	70	65	58	51	45	40	67
275	0.000	79	80	76	71	65	57	51	46	73
	0.250	80	82	76	71	63	56	50	46	73
325	0.000	83	85	80	76	70	63	56	51	78
	0.250	83	87	80	77	69	62	55	51	78
375	0.000	85	89	84	81	75	68	60	55	82
	0.250	85	92	84	82	74	66	60	55	83
	0.500	84	92	84	81	73	66	59	54	82
425	0.000	87	92	88	84	78	72	64	58	85
	0.250	87	93	88	85	79	71	64	58	86
	0.500	87	94	88	84	78	70	63	58	86
	0.750	87	94	88	84	77	70	63	58	85
475	0.000	89	94	91	87	82	75	67	61	89
	0.500	89	95	92	87	82	74	67	61	89
	0.750	88	96	92	87	81	74	66	61	89
	1.000	88	95	92	87	80	73	66	61	88
525	0.000	91	96	94	90	85	78	71	64	91
	0.500	91	97	95	90	85	78	70	64	92
	0.750	90	97	96	90	85	77	70	64	92
	1.000	90	97	96	90	84	77	69	64	92
	1.250	90	97	95	89	84	77	69	64	91
575	0.250	93	98	98	92	88	81	74	67	94
	0.500	93	98	98	93	88	81	73	67	95

**445 TCNH-B**

RPM	SP	SOUND POWER re 10 <sup>-12</sup> WATTS								
		OCTAVE BANDS								L <sub>wi</sub> A
		1	2	3	4	5	6	7	8	
450	1.000	82	86	81	80	74	67	61	56	81
500	1.000	85	89	86	83	78	71	65	59	85
	1.250	83	88	85	82	77	71	64	59	83
550	1.000	88	92	90	86	82	74	67	62	87
	1.500	85	90	88	84	81	74	67	61	86
600	1.000	89	94	92	88	85	77	70	64	90
	1.500	88	93	92	87	84	77	70	64	89
650	1.750	87	92	91	86	84	76	70	64	89
	1.000	91	95	95	90	87	80	72	66	92
	1.500	90	95	95	90	87	80	73	66	92
700	2.000	88	94	94	88	86	79	73	66	91
	1.000	92	97	97	92	90	83	75	68	95
	1.500	92	97	97	92	90	82	75	68	94
	2.000	91	96	97	91	89	82	75	69	94
750	2.500	89	94	96	89	89	81	75	68	93
	1.000	93	99	99	94	92	85	77	70	97
	1.500	93	98	99	93	92	85	77	70	96
	2.000	93	98	99	93	92	84	78	71	96
800	2.500	92	97	99	92	91	83	77	70	96
	1.000	94	100	101	96	93	87	79	72	98
	1.500	94	100	101	95	93	87	79	72	98
	2.000	94	99	101	95	93	86	79	72	98
850	2.500	94	99	101	95	93	86	80	73	98
	3.000	92	98	100	93	93	85	79	72	97

**490 TCNH-B**

RPM	SP	SOUND POWER re 10 <sup>-12</sup> WATTS								
		OCTAVE BANDS								L <sub>wi</sub> A
		1	2	3	4	5	6	7	8	
425	1.000	85	88	83	82	75	69	62	57	82
475	1.000	88	92	88	85	80	73	66	60	86
	1.250	87	91	87	85	79	72	66	60	85
525	1.000	90	94	91	88	83	76	69	63	89
	1.250	90	94	91	88	83	76	69	63	89
575	1.500	89	93	90	87	82	75	69	63	88
	1.000	92	96	94	90	86	79	71	65	92
	1.500	92	96	94	90	86	79	72	66	92
	1.750	90	95	93	89	85	78	72	66	91
625	2.000	89	94	92	88	85	78	71	65	90
	1.000	93	98	97	92	89	82	74	68	94
	1.500	93	98	97	92	89	81	74	68	94
675	2.000	92	97	96	91	88	81	75	68	94
	1.000	95	99	99	94	91	85	77	70	96
	1.500	94	99	99	94	91	84	76	70	96
	2.000	94	99	99	94	91	84	77	71	96
725	2.500	93	98	98	92	91	83	77	70	95
	1.000	96	101	101	96	94	87	79	72	99
	1.500	96	101	101	96	94	87	79	72	98
	2.000	96	101	101	96	94	86	79	72	98
	2.500	95	101	101	95	93	86	80	73	98
3.000	94	99	100	94	93	85	79	72	97	

The sound power level ratings shown are in decibels referred to 10<sup>-12</sup> watts calculated per AMCA Standard 301. The A-weighted sound ratings shown have been calculated per AMCA Standard 301. Values shown are for inlet L<sub>wi</sub> and inlet L<sub>wi</sub>A sound power levels for Installation Type B: free inlet, ducted outlet.



## **LOREN COOK COMPANY**

2015 E. DALE STREET  
SPRINGFIELD, MO 65803-4637

417.869.6474

FAX 417.862.3820

[lorencook.com](http://lorencook.com)