

MARK: _____
 PROJECT: _____
 DATE: _____



Vari-Plume®
Laboratory Exhaust
Mixed-Flow Inline
Bifurcated Belt Drive
With 1x3 Mixing Box
Parallel Bypass

DIMENSION DATA

Size	A	B	C	D	E	F	G Height	H	J Width	K	L	M	Unit Weight	
													STD	HP
90	92 3/16	28	27 3/16	24 7/16	36 11/16	38	10 9/16	8	19 3/4	99 1/2	100	36 1/2	2233	2247
120	108 9/16	28	27 3/16	32 9/16	40 7/16	40	12 13/16	8	19 3/4	99 1/2	100	36 1/2	2567	2572
135	117 1/8	28	27 1/8	36 11/16	41 5/8	40	14 13/16	8	18 9/16	108 3/8	108 7/8	41	3256	3260
150	118 3/16	30	29 1/8	38 5/16	44 1/8	43	16 9/16	8	20 9/16	112 3/8	112 7/8	42	3426	3431
165	127 11/16	32	31 1/8	42 1/8	45 1/2	46	18 5/16	8	22 9/16	122 3/8	122 7/8	46	3895	3932
180	137 1/16	34	33 1/8	46	48	49	19 1/16	8	24 9/16	134 3/8	134 7/8	51	4619	4650
202	150	38	36 15/16	51 3/4	51 7/8	54	22 9/16	8	28 9/16	150 1/8	150 7/8	57	5564	5602
225	162 15/16	42	40 15/16	57 1/2	58	59	22 9/16	9	30 9/16	166 1/8	166 7/8	63	6308	6400
245	175 1/16	44	42 15/16	62 9/16	60 5/8	62	24 13/16	9	32 9/16	180 3/16	180 7/8	69	7420	7485
270	173 13/16	48	46 15/16	66 3/8	64 5/8	67	26 9/16	9	36 9/16	190 3/16	190 7/8	72	8384	8432
300	192 1/8	52	50 15/16	73 3/4	69 7/16	72	29 13/16	9	40 9/16	210 3/16	210 7/8	80	10228	10289
330	207 15/16	56	54 13/16	81 1/8	75 15/16	78	33 1/16	9	44 9/16	230 3/8	230 7/8	88	11274	11352
365	228 7/8	62	60 3/4	89 3/4	81 5/8	87	35 1/16	11	46 7/16	255 3/4	257 1/2	98	14854	15023
402	249 11/16	67	65 5/8	98 15/16	89 5/16	107	41 5/16	11	50 3/8	280 7/8	282 1/2	108	18033	18206
445	278 3/8	74	72 5/8	109 3/8	96 1/8	102	47 1/16	13	55 3/8	309 7/8	311 1/2	119	21456	21604
490	308 1/4	80	78 1/2	120 7/16	104 1/16	118	57 5/16	13	59 3/16	339 3/4	341 1/4	131	34697	34921
540	338 15/16	87	85 3/8	132 3/4	111 3/8	131	66 1/16	15	62 3/16	374 7/8	379 1/2	145	41320	41740
600	386 9/16	96	94 3/8	147 1/2	120 5/16	149	81 9/16	15	69 3/16	415 7/8	417 1/2	161	49843	50365

ALL DIMENSIONS IN INCHES. WEIGHTS IN LBS., LESS MOTOR.
 * RECOMMENDED CURB OUTSIDE SQUARE DIMENSION.
 ** MIXING BOX INSIDE SQUARE DIMENSION.
 *** DIMENSION IS FROM THE BOTTOM OF THE CURB CAP TO THE TOP OF THE CURB.

STANDARD CONSTRUCTION FEATURES:

High efficiency, non-overloading mixed-flow welded wheel -
 Minimum 14 gauge steel welded bifurcated housing - Welded aerodynamic straightening vanes - Double concentric accelerator aluminum induction nozzle and windband - Phenolic epoxy powder with UV protection (Light Gray) - L10/40k Concentric locking regreasable bearings - Bolted access door - Lifting lugs - Fan drain - Weather cover - Reinforced curb cap - Stainless Steel shaft - Stainless Steel hardware - Stainless Steel extended lube lines - NEMA 3R disconnect mounted and pre-wired - 1.5 Service factor drives - Designed to withstand 125 mph wind****

BYPASS PLENUM: Single wall welded steel construction with inner angle frame - Bottom inlet location - Phenolic epoxy powder with UV protection (Light Gray) - Plenum drain - Bolted access door - Painted aluminum bypass damper with manual hand quadrant - Painted aluminum isolation damper with 2 position actuator - Weather hood - Stainless steel birdscreen - Stainless Steel hardware - Designed to withstand 125 mph wind****

OPTIONAL FEATURES SHOWN:

Heavy Duty Lab Exhaust Curb
 Side Intake Opening
 Damper Actuator

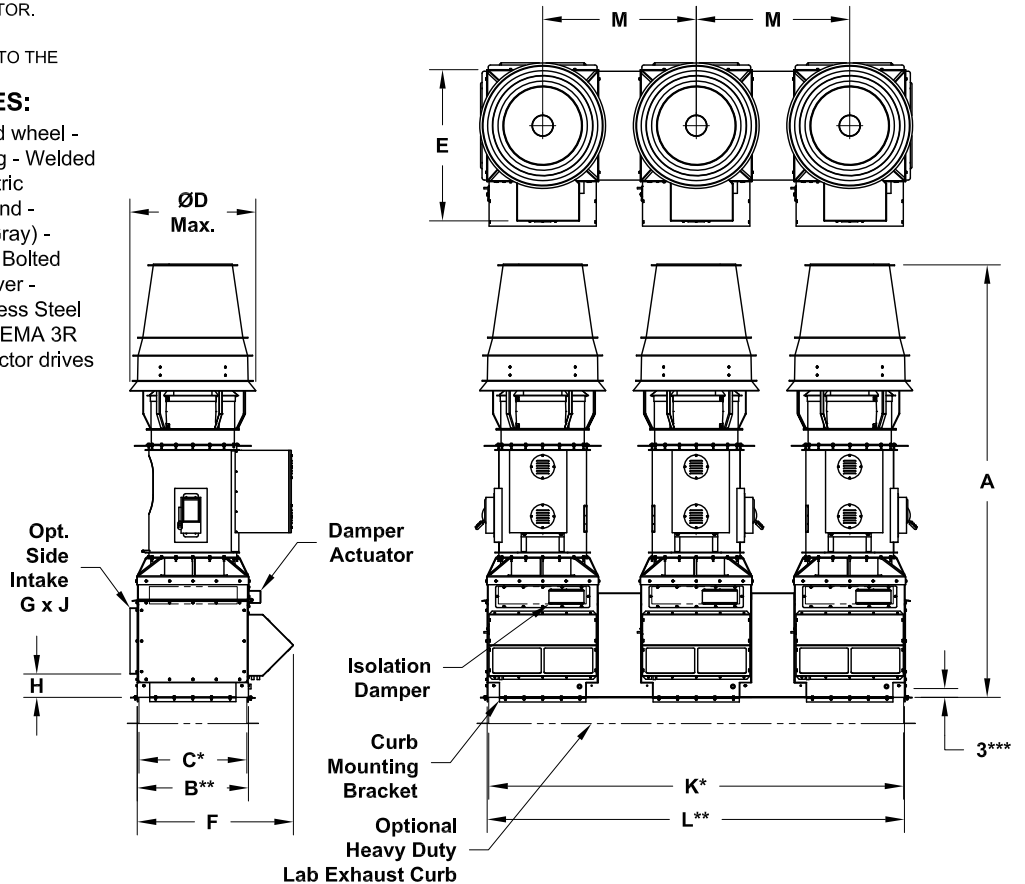

NOT INTENDED TO BE SUPPORTED BY TRADITIONAL SHEETMETAL ROOF CURB, BUT BY INTEGRAL MEMBERS OF ROOF STRUCTURE.
 **** WINDLOAD RATING DEPENDANT ON ADEQUATE ATTACHMENT TO ROOF STRUCTURE.