



COOK CP Inlet Box Canted Curb

DATE: _____

Galvanized Steel
Canted Roof Curb

PROJECT: _____

LOCATION: _____

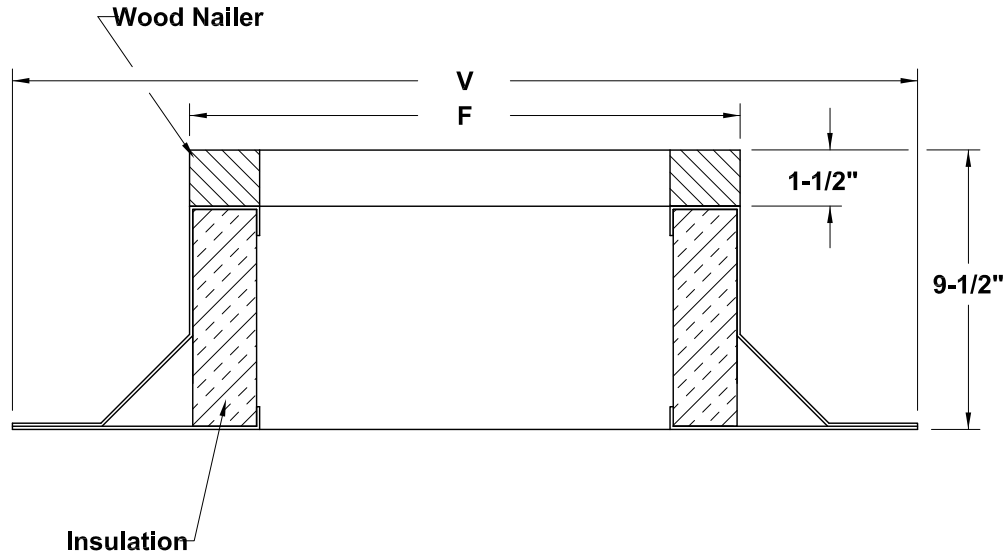

DIMENSION DATA

STANDARD CONSTRUCTION FEATURES:

Minimum 18 gauge galvanized steel - 1-1/2", 3 lbs. density thermal and acoustical insulation - Continuously welded corners - Wood nailer.

- Options: 1) No wood nailer (deduct 1-1/2" for actual height)
2) 13-1/2" high

DIMENSION DATA

Qty.	Mark	CP Size	Cat. No.	F	V	Matl. Gauge	Ship Weight
		60	RCG-30 X 46	30 X 46	38 X 54	18	105
		70	RCG-30 X 46	30 X 46	38 X 54	18	105
		80	RCG-30 X 46	30 X 46	38 X 54	18	105
		100	RCG-30 X 46	30 X 46	38 X 54	18	105
		120	RCG-30 X 47	30 X 47	38 X 55	18	107
		135	RCG-32 X 52	32 X 52	40 X 60	18	116
		150	RCG-35 X 54	35 X 54	43 X 62	18	123
		165	RCG-37 X 57	37 X 57	45 X 65	18	130
		180	RCG-39 X 59	39 X 59	47 X 67	18	136
		195	RCGH-42 X 65	42 X 65	50 X 73	16	148
		210	RCGH-46 X 68	46 X 68	54 X 76	16	158
		225	RCGH-48 X 71	48 X 71	56 X 79	16	165
		245	RCGH-50 X 74	50 X 74	58 X 82	16	172

ALL DIMENSIONS IN INCHES. WEIGHTS IN LBS.