

MARK: _____
 PROJECT: _____
 DATE: _____

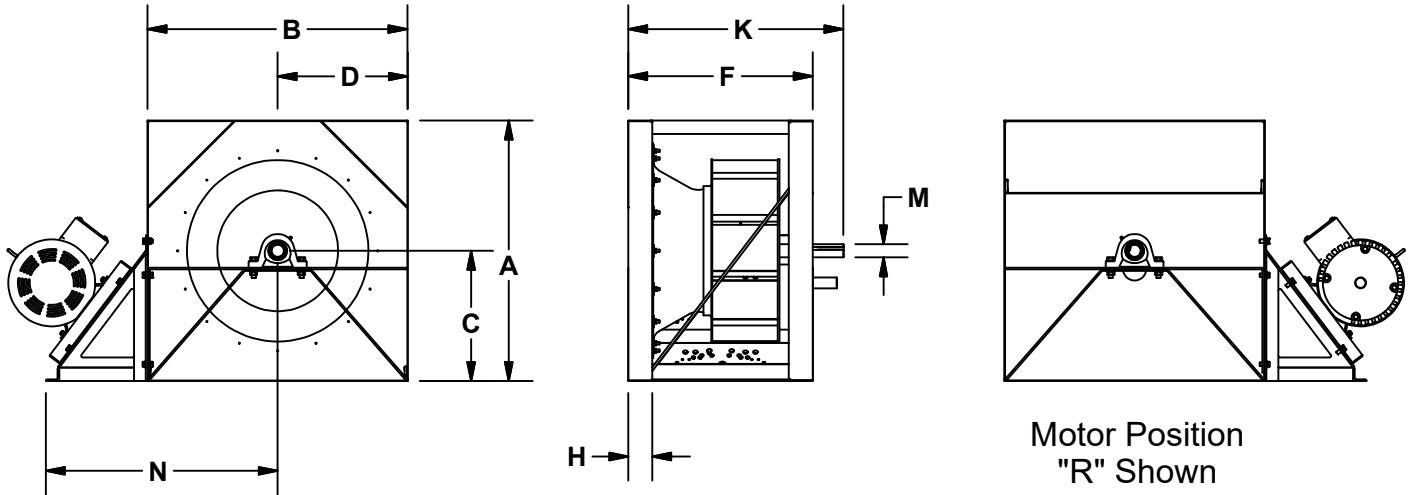

**Centrifugal Plenum Fan
 Side Mount
 Arrangement 3S
 Class I**



STANDARD CONSTRUCTION FEATURES:

UL 705 Listed - AMCA Air and Sound certified performance - Heavy duty structural steel frame with heavy gauge inlet panels welded at all connections - Continuously welded, airfoil wheel - Heavy gauge spun aluminum inlet cone.

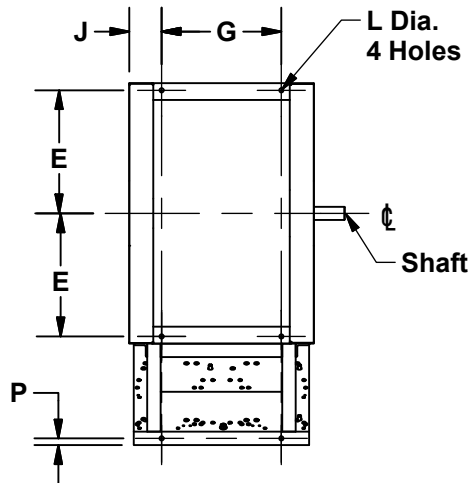

DIMENSION DATA

Size	A	B	C	D	E	F	G	H	J	K	L	M	N	P	Unit Wt.
120	17 1/4	17 1/4	8 5/8	8 5/8	7 11/16	13 1/16	7 7/16	1 13/16	2 13/16	16 15/16	5/8	1 3/16	16 3/4	5/8	143
135	19 1/2	19 1/2	9 3/4	9 3/4	8 13/16	14 5/8	8 1/2	2 1/16	3 1/16	18 1/2	5/8	1 3/16	18 5/8	5/8	161
150	21 1/2	21 1/2	10 3/4	10 3/4	9 13/16	15 9/16	9 7/16	2 1/16	3 1/16	19 7/16	5/8	1 3/16	20 1/8	5/8	174
165	23 3/4	23 3/4	11 7/8	11 7/8	10 15/16	16 3/4	10 5/8	2 1/16	3 1/16	20 5/8	5/8	1 3/16	21 3/4	5/8	193
180	25 3/4	25 3/4	12 7/8	12 7/8	12	19 7/8	11 3/4	3 1/16	4 1/16	24	5/8	1 7/16	23 1/4	5/8	260
195	28	28	14	14	13 1/8	21	12 7/8	3 1/16	4 1/16	25 1/8	5/8	1 7/16	25	1	285
210	30	30	15	15	14 1/8	22 1/16	13 15/16	3 1/16	4 1/16	26 3/16	5/8	1 7/16	26 1/2	1	296
225	32 1/4	32 1/4	16 1/8	16 1/8	15 1/4	23 1/16	14 15/16	3 1/16	4 1/16	27 3/16	5/8	1 7/16	28 1/8	1	315
245	35	35	17 1/2	17 1/2	16 3/8	24 1/2	15 7/8	3 1/16	4 5/16	38 3/4	5/8	1 7/16	30 1/8	1	380
270	38 3/4	38 3/4	19 3/8	19 3/8	18 1/4	27 7/16	17 13/16	3 9/16	4 13/16	31 11/16	5/8	1 7/16	34 1/2	1	469
300	43	43	21 1/2	21 1/2	20 3/16	29 1/2	19 3/8	3 9/16	5 1/16	33 7/8	5/8	1 11/16	35 5/8	1	761
330	49 1/2	46	23 5/8	23	22 5/16	32 3/16	26 3/8	3 9/16	4 11/16	38 13/16	15/16	1 15/16	37 5/8	1	737
365	53 1/2	49	26 1/8	24 1/2	23 13/16	34 9/16	28 3/4	3 9/16	4 11/16	39 5/16	15/16	1 15/16	40	1	718
402	60	54	28 3/4	27	26 1/4	39 7/16	32 5/8	4 9/16	5 11/16	44 7/16	15/16	2 7/16	43 7/8	1	1220
445	64	58 1/2	31 7/8	29 1/4	28 1/2	43	35 5/8	5 1/16	6 1/4	48 1/8	15/16	2 7/16	47 1/8	1	1525
490	70	63	35	31 1/2	30 5/8	47 1/4	39 7/8	5 1/16	6 1/4	52 5/8	15/16	2 7/16	50 3/8	1	1782
540	75	69	38 5/8	34 1/2	33 5/8	50 7/8	43 1/2	5 1/8	6 1/4	56 1/2	1 1/16	2 7/16	54 1/4	1 1/4	1981
600	82	75	42 7/8	37 1/2	36 5/8	56 1/4	47 7/8	6 1/8	7 1/4	62 1/4	1 1/16	2 11/16	57 7/8	1 1/4	2586
660	90	82	47 1/4	41	40	63 11/16	54 5/16	7 1/8	8 1/4	70 5/16	1 1/16	2 15/16	62 7/8	1 1/2	3382
730	92	92	52 1/4	46	45	69 11/16	59 5/16	8 1/8	9 1/4	76 15/16	1 1/16	3 7/16	68 1/2	1 1/2	4328

ALL DIMENSIONS IN INCHES. WEIGHTS IN LBS., LESS MOTOR AND SLIDE BASE.