



COOK

Discharge Shutter

DATE: _____

PROJECT: _____

LOCATION: _____

Accessory Data Sheet
 Aluminum Construction
 CA DWDI

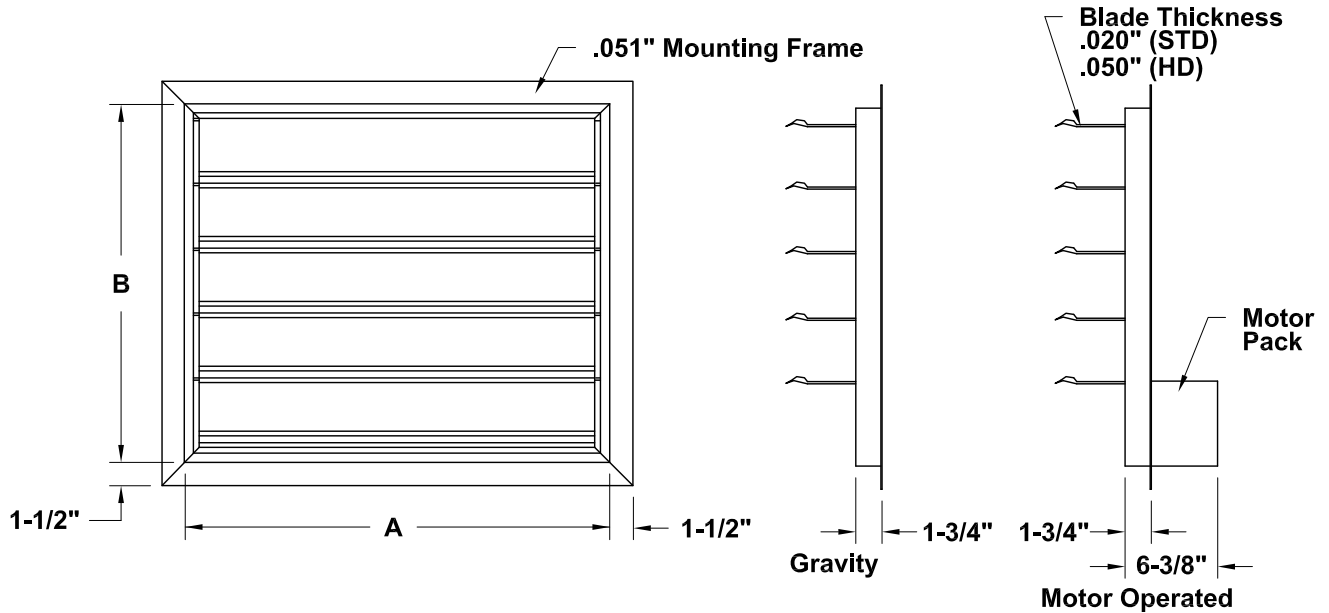

DIMENSION DATA

Size	Shutter Model Number*				A	B	Shipping Wt.			
	Gravity		Motor Operated				Gravity		Motor Operated	
	Std. Duty	Hvy. Duty	Std. Duty	Hvy. Duty			Std. Duty	Hvy. Duty	Std. Duty	Hvy. Duty
120	ADSS-120D	ADSH-120D	MDSS-120D	MDSH-120D	17-11/16	12-1/8	3	5	8	10
135	ADSS-135D	ADSH-135D	MDSS-135D	MDSH-135D	19-15/16	13-5/8	4	7	9	12
150	ADSS-150D	ADSH-150D	MDSS-150D	MDSH-150D	22	15-1/4	5	8	10	13
165	ADSS-165D	ADSH-165D	MDSS-165D	MDSH-165D	24	16-15/16	6	9	11	14
180	ADSS-180D	ADSH-180D	MDSS-180D	MDSH-180D	26-1/16	18-1/2	7	11	12	16
195	ADSS-195D	ADSH-195D	MDSS-195D	MDSH-195D	28-7/16	19-1/2	8	13	13	18
210	ADSS-210D	ADSH-210D	MDSS-210D	MDSH-210D	30-3/8	21-5/8	10	14	15	19
225	ADSS-225D	ADSH-225D	MDSS-225D	MDSH-225D	32-1/2	23-3/16	11	16	16	21
245	ADSS-245D	ADSH-245D	MDSS-245D	MDSH-245D	35-1/16	25-1/2	13	19	23	29
270	ADSS-270D	ADSH-270D	MDSS-270D	MDSH-270D	39-7/16	27-1/2	16	23	26	33
300	ADSS-300D	ADSH-300D	MDSS-300D	MDSH-300D	43	31-3/16	19	28	29	38
330	ADSS-330D	ADSH-330D	MDSS-330D	MDSH-330D	47-1/16	34-1/2	23	35	33	45
365	ADSS-365D	ADSH-365D	MDSS-365D	MDSH-365D	52-3/16	38-11/16	28	42	38	52
402	ADSS-402D	ADSH-402D	MDSS-402D	MDSH-402D	57-13/16	41-3/4	33	50	43	60
445	ADSS-445D	ADSH-445D	MDSS-445D	MDSH-445D	64-1/4	45-15/16	41	61	51	71
490	ADSS-490D	ADSH-490D	MDSS-490D	MDSH-490D	70-1/8	51	49	74	64	89
540	ADSS-540D	ADSH-540D	MDSS-540D	MDSH-540D	77-15/16	55-3/4	59	88	74	103
600	ADSS-600D	ADSH-600D	MDSS-600D	MDSH-600D	86-1/4	62-3/16	73	109	88	124
660	ADSS-660D	ADSH-660D	MDSS-660D	MDSH-660D	94-7/8	68-7/16	88	132	103	147
730	ADSS-730D	ADSH-730D	MDSS-730D	MDSH-730D	104-3/4	75-13/16	106	158	126	178

ALL DIMENSIONS IN INCHES.

*USE STANDARD DUTY SHUTTER FOR DISCHARGE VELOCITIES OF 0-2000 FPM. MOTOR OPERATED DAMPERS REQUIRED FOR VELOCITIES BELOW 400 FPM. USE HEAVY DUTY SHUTTER FOR DISCHARGE VELOCITIES OF 2000-3000 FPM. VELOCITIES ABOVE 3000 FPM, CONTACT FACTORY.

STANDARD CONSTRUCTION FEATURES:

Blades are roll formed 5052 aluminum (Std.) or extruded 6063 T6 aluminum (Hvy.). Blades have vinyl edge gasket. Damper frame is extruded 6063 T6 aluminum. Extruded aluminum blade link bar connects each blade for uniform blade positioning. Blades pivot on full width extruded aluminum blade hanger for added strength.

- NOTES: 1) SIZE 120-225 REQUIRES 1 MOTOR.
 2) SIZE 245-445 REQUIRES 2 MOTORS.
 3) SIZE 490-660 REQUIRES 3 MOTORS.
 4) SIZE 730 REQUIRES 4 MOTORS.