

DATE: \_\_\_\_\_  
 PROJECT: \_\_\_\_\_  
 LOCATION: \_\_\_\_\_

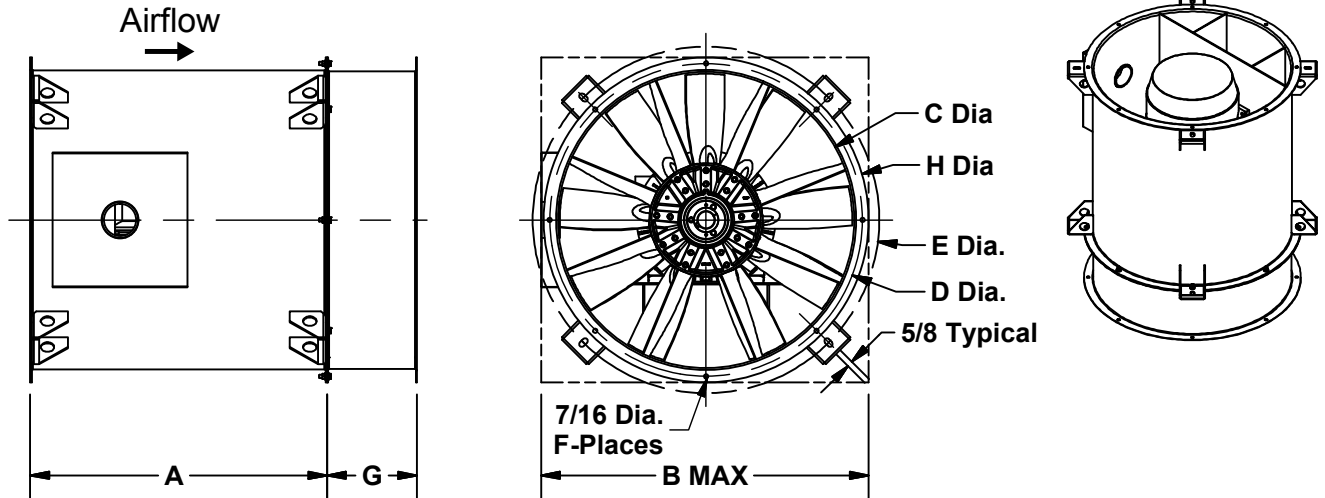

**Axial Inline Fan  
 Vertical Mount  
 Direct Drive  
 Arrangement 4, Level I  
 Vane Section Accessory**



**STANDARD CONSTRUCTION FEATURES:**

High efficiency, heavy duty cast aluminum impeller - Continuously welded steel housing with Lorenized powder coating - Integral pre-punched inlet and outlet flanges - Corrosion resistant fasteners - Lifting Lugs - Rigid motor support welded to housing - Totally enclosed motor - Motor leads extended to exterior of the housing to a NEMA 1 wiring compartment

**DIMENSION DATA**

Size	A	B	C	D	E	F	G	H	Max Motor Frame	Unit Wt.
31	19	17 3/8	12 1/2	14 1/8	17 9/16	8	10	15 1/4	145T	74
36	19	18 13/16	14 1/2	16 1/8	19 5/8	8	10	17 1/4	145T	84
41	22	20 5/16	16 1/2	18 1/8	21 11/16	8	10	19 1/4	184T	111
47	22	21 7/8	18 5/8	20 1/4	23 15/16	8	10	21 3/4	184T	127
54	22	24 7/8	21 5/8	23 5/16	27 1/16	8	10	24 3/4	184T	168
63	22	28	24 5/8	26 5/16	30 1/16	8	10	27 7/8	184T	192
72	26	32 5/16	28 7/8	30 9/16	34 3/8	8	10	32 1/8	215T	268
80	33	36 3/8	32 7/8	34 3/4	38 1/2	8	10	36 1/8	286T	422
90	39	41 5/16	37	39 1/4	42 15/16	8	11 3/8	41 1/4	324T	637
103	39	45 5/8	41 1/8	43 3/8	47 1/16	8	12 3/8	45 3/8	324T	710
113	39	49 7/8	45 1/4	47 1/2	51 3/16	8	13 3/8	49 1/2	365T	965
123	41	54 3/16	49 3/8	51 5/8	55 5/16	16	14 3/8	53 3/4	365T	1091
140	41	60 15/16	56	58 1/4	61 15/16	16	15 7/8	60 3/8	365T	1407
160	41	69 3/16	64 1/8	66 3/8	70 1/16	16	17 13/16	68 1/2	365T	1632

ALL DIMENSIONS IN INCHES. WEIGHTS IN LBS., LESS MOTOR.