



COOK

INLET VANE DAMPER

DATE: _____

PROJECT: _____

LOCATION: _____

Accessory Data Sheet

External

CA SWSI, CF SWSI, CIC

SQI, SQN, TCN, TCNH

DIMENSION DATA

Size	A	B	C	D	Ship Wt.	
					Alum.	Steel
120	12-7/8	15-7/8	10	16	20	59
135	14-3/8	17-3/8	10	16	23	69
150	15-7/8	18-7/8	10	16	26	79
165	17-3/8	20-3/8	10	16-1/4	30	89
180	18-7/8	21-7/8	10	16-1/4	33	98
195	20	23	10	16-3/4	36	108
210	21-3/4	24-3/4	10	16-3/4	39	117
225	23-1/4	26-1/4	10	16-3/4	42	126
245	25-1/4	28-1/4	10	16-3/4	47	141
270	27-1/4	31-1/4	10	16-1/2	54	161
300	30-1/4	34-1/4	10	16-1/2	62	185
330	33-1/4	37-1/4	10	16-1/2	70	209
365	36-3/4	40-3/4	10	16-1/2	79	237
402	40-1/2	44-1/2	11	17-1/2	89	267
445	44-3/4	48-3/4	11	17-1/2	100	301
490	50-1/4	54-1/4	11	18	112	337
540	55-1/4	59-1/4	12	20	126	377
600	61-1/4	65-1/4	12	20	142	425
660	67-1/4	71-1/4	12	20	158	473
730	74-1/4	78-1/4	12	21	176	529

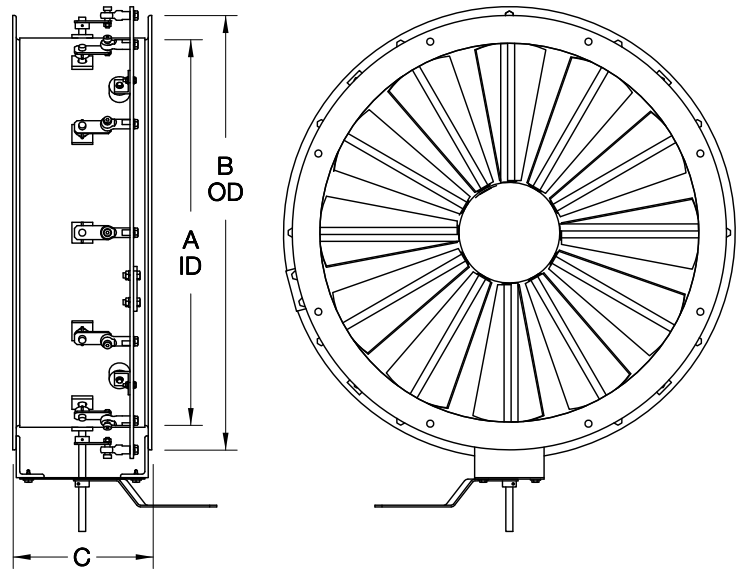

ALL DIMENSIONS IN INCHES. WEIGHTS IN LBS.

NOTE: NOT OFFERED ON 120 SQN.

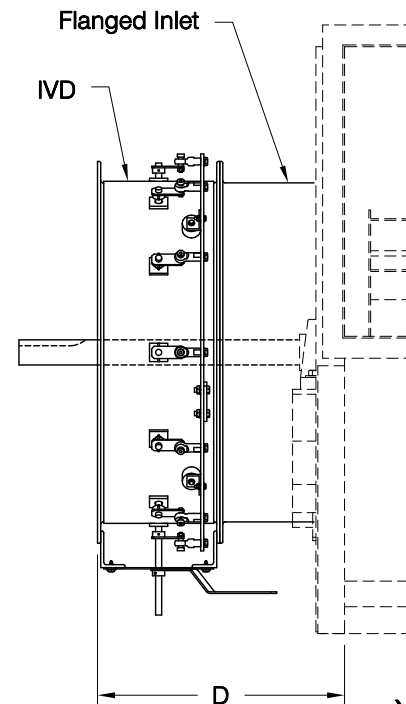

X0403R05