



COOK

Bypass Damper

DATE: _____
 PROJECT: _____
 LOCATION: _____

Accessory Data Sheet
 Bypass Damper
 Low Leakage Class 1A Rated
 for TCNHBLE Mixing Box
 Aluminum

STANDARD CONSTRUCTION FEATURES:

- Frame: 5" x 1" x 6063T5 extruded hat channel with .125" minimum wall thickness
- Blades: 6" wide, 6063T5 heavy gauge extruded aluminum, airfoil shape. Opposed blade standard.
- Seals: Synthetic polymer blade edge seals and flexible SS compressible jamb seals.
- Bearings: Molded synthetic.
- Linkage: Concealed in frame.
- Axles: 1/2" plated steel hex.
- Temperature Limits: -72°F and +275°F.
- Damper provided with manual hand quadrant.
- Finish: Air-dry enamel coating to match fan color.
- One panel per damper selection.

OPTIONAL CONSTRUCTION FEATURES:

- Air-dry epoxy finish.
- Actuator out of Airstream, 1 Actuator per panel, protected from weather. Available in 24vdc or 24vac. See table below for optional actuator model. Power Open/Spring Close (Reversible).
- Pneumatic actuator.

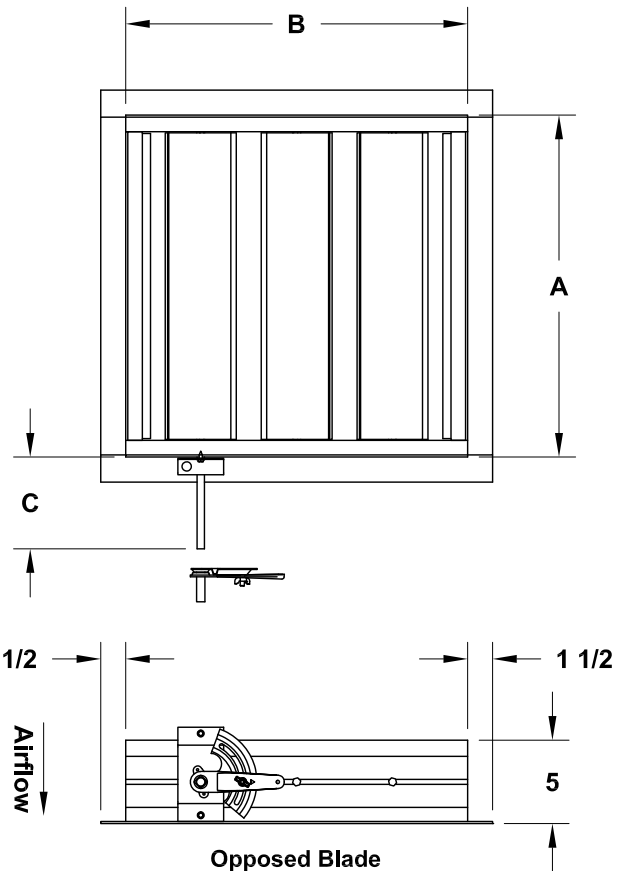
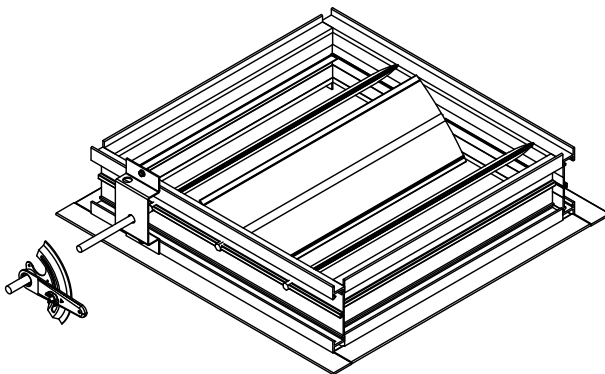

DIMENSION DATA

| Qty | Mark | Size | A | B | C | Actuator Model | Unit Weight | |
|-----|------|------|--------|--------|----|----------------|-------------|----------|
| | | | | | | | Quadrant | Actuator |
| | | 100 | 12-1/2 | 5-3/4 | 5 | LF24-SR-S | 3 | 7 |
| | | 120 | 16-1/2 | 6-3/4 | 5 | LF24-SR-S | 4 | 8 |
| | | 135 | 18-1/2 | 7 | 5 | LF24-SR-S | 5 | 9 |
| | | 150 | 20-1/2 | 7-3/4 | 5 | LF24-SR-S | 6 | 10 |
| | | 165 | 22-1/2 | 9-1/4 | 5 | LF24-SR-S | 8 | 11 |
| | | 180 | 25-1/2 | 10-1/4 | 5 | LF24-SR-S | 10 | 13 |
| | | 195 | 28-1/2 | 11 | 6 | LF24-SR-S | 12 | 15 |
| | | 210 | 30-1/2 | 9-3/4 | 6 | LF24-SR-S | 11 | 14 |
| | | 225 | 34-1/2 | 10-1/2 | 6 | LF24-SR-S | 13 | 17 |
| | | 245 | 36-1/2 | 12-3/4 | 6 | LF24-SR-S | 17 | 20 |
| | | 270 | 40-1/2 | 12-3/4 | 6 | LF24-SR-S | 19 | 22 |
| | | 300 | 46-1/2 | 13-1/2 | 6 | LF24-SR-S | 23 | 26 |
| | | 330 | 48 | 16-3/4 | 7 | LF24-SR-S | 29 | 32 |
| | | 365 | 48 | 19-1/2 | 8 | LF24-SR-S | 33 | 37 |
| | | 402 | 48 | 21-3/4 | 12 | NFB24-SR-S | 37 | 44 |
| | | 445 | 48 | 28-1/2 | 14 | NFB24-SR-S | 49 | 55 |
| | | 490 | 48 | 34-1/2 | 17 | NFB24-SR-S | 59 | 65 |

ALL DIMENSIONS IN INCHES. WEIGHTS IN LBS. WEIGHT INCLUDES HAND QUADRANT OR ACTUATOR.

X0228R00