

MARK: _____
 PROJECT: _____
 DATE: _____



Vari-Plume®
 Laboratory Exhaust
 Mixed-Flow Inline
 Belt Drive
 With 1x2 Mixing Box
 Parallel Bypass

DIMENSION DATA

Size	A	B	C	D	E	F	G Height	H	J Width	K	L	M	Unit Weight	
													STD	HP
90	92 3/16	28	27 3/16	24 7/16	36 11/16	38	10 9/16	8	19 3/4	63 5/16	64	36 1/2	1467	1476
120	108 9/16	28	27 3/16	32 9/16	40 7/16	39	12 13/16	8	19 3/4	63 5/16	64	36 1/2	1689	1693
135	117 1/8	28	27 1/8	36 11/16	41 5/8	40	14 13/16	8	18 9/16	67 3/4	68 7/16	41	2141	2144
150	118 3/16	30	29 1/8	38 5/16	44 1/8	43	16 9/16	8	20 9/16	70 3/4	71 7/16	42	2250	2254
165	127 11/16	32	31 1/8	42 1/8	45 1/2	46	18 5/16	8	22 9/16	76 3/4	77 7/16	46	2564	2589
180	137 1/16	34	33 1/8	46	48	48	19 1/16	8	24 9/16	83 3/4	84 7/16	51	3029	3050
202	150	38	36 15/16	51 3/4	51 7/8	54	22 9/16	8	28 9/16	93 9/16	94 7/16	57	3658	3684
225	162 15/16	42	40 15/16	57 1/2	58	59	22 9/16	9	30 9/16	103 9/16	104 7/16	63	4163	4224
245	175 1/16	44	42 15/16	62 9/16	60 5/8	62	24 13/16	9	32 9/16	111 9/16	112 7/16	69	4876	4919
270	173 13/16	48	46 15/16	66 3/8	64 5/8	67	26 9/16	9	36 9/16	118 9/16	119 7/16	72	5526	5558
300	192 1/8	52	50 15/16	73 3/4	69 7/16	72	29 13/16	9	40 9/16	130 9/16	131 7/16	80	6702	6743
330	207 15/16	56	54 13/16	81 1/8	75 15/16	78	33 1/16	9	44 9/16	142 9/16	143 7/16	88	7464	7516
365	228 7/8	62	60 3/4	89 3/4	81 5/8	86	35 1/16	11	46 7/16	158 1/4	159 1/4	98	9812	9924
402	249 11/16	67	65 5/8	98 15/16	89 5/16	94	41 5/16	11	50 3/8	173 1/4	174 1/4	108	11943	12058
445	278 3/8	74	72 5/8	109 3/8	96 1/8	106	47 1/16	13	55 3/8	191 1/4	192 1/4	119	14258	14356
490	308 1/4	80	78 1/2	120 7/16	104 1/16	117	57 5/16	13	59 3/16	209 1/8	210 1/8	131	23049	23198
540	338 15/16	87	85 3/8	132 3/4	111 3/8	130	66 1/16	15	62 3/16	230 1/8	231 1/4	145	27513	27793
600	386 9/16	96	94 3/8	147 1/2	120 5/16	148	81 9/16	15	69 3/16	255 1/8	256 1/4	161	33286	33634

ALL DIMENSIONS IN INCHES. WEIGHTS IN LBS., LESS MOTOR.
 * RECOMMENDED CURB OUTSIDE SQUARE DIMENSION.
 ** MIXING BOX INSIDE SQUARE DIMENSION.
 *** DIMENSION IS FROM THE BOTTOM OF THE CURB CAP TO THE TOP OF THE CURB.

STANDARD CONSTRUCTION FEATURES:

High efficiency, non-overloading mixed-flow welded wheel - Minimum 14 gauge steel welded housing - Welded aerodynamic straightening vanes - Double concentric accelerator aluminum induction nozzle and windband - Phenolic epoxy powder with UV protection (Light Gray) - L10/40k Concentric locking regreasable bearings - Bolted access door - Lifting lugs - Fan drain - Weather cover - Reinforced curb cap - Stainless Steel shaft - Stainless Steel hardware - Stainless Steel extended lube lines - NEMA 3R disconnect mounted and pre-wired - 1.5 Service factor drives - Designed to withstand 125 mph wind****

BYPASS PLENUM: Single wall welded steel construction with inner angle frame - Bottom inlet location - Phenolic epoxy powder with UV protection (Light Gray) - Plenum drain - Bolted access door - Painted aluminum bypass damper with manual hand quadrant - Painted aluminum isolation damper with 2 position actuator - Weather hood - Stainless steel birdscreen - Stainless Steel hardware - Designed to withstand 125 mph wind****

OPTIONAL FEATURES SHOWN:

Heavy Duty Lab Exhaust Curb
 Side Intake Opening
 Damper Actuator

Optional Side Intake
 G x J

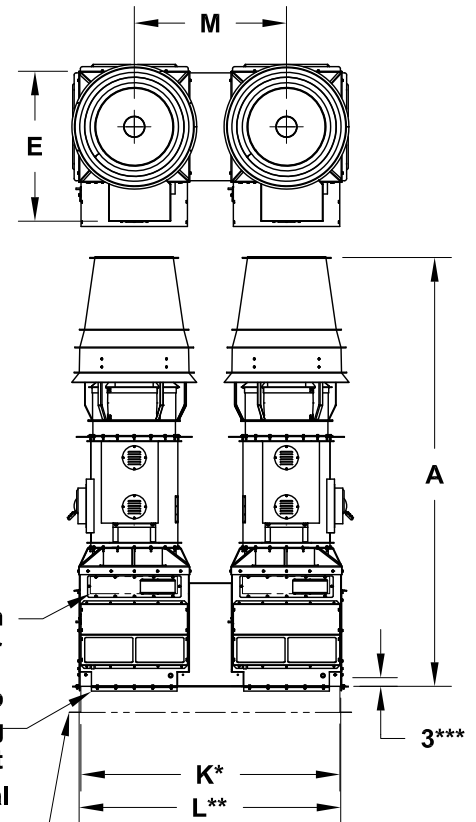
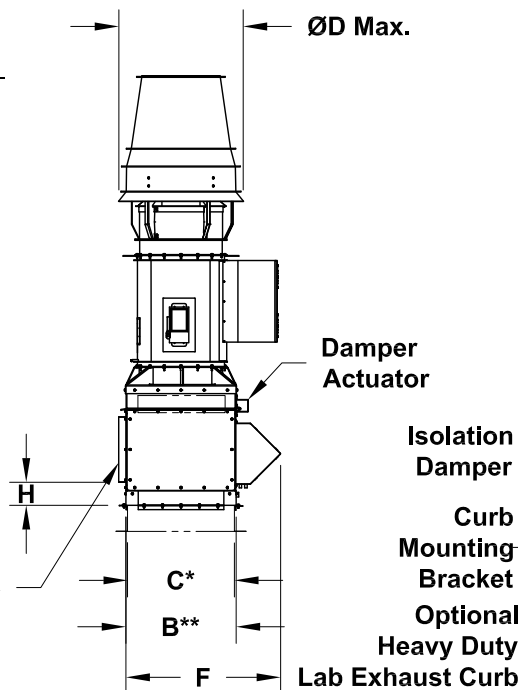

NOT INTENDED TO BE SUPPORTED BY TRADITIONAL SHEETMETAL ROOF CURB, BUT BY INTEGRAL MEMBERS OF ROOF STRUCTURE.
 **** WINDLOAD RATING DEPENDANT ON ADEQUATE ATTACHMENT TO ROOF STRUCTURE.