



# COOK

# AVAB

DATE: \_\_\_\_\_

PROJECT: \_\_\_\_\_

LOCATION: \_\_\_\_\_



## Adjustable Pitch Vane Axial Upblast Ceiling Mount Belt Drive Arrangement 9

### DIMENSION DATA

Size	A	B	C	D	E	F	G	H	J	K	L
35	35-1/2	39-7/8	38	3/16	43	9/16	12	47-7/8	43-1/8	9/16	30-1/2
39	39-3/8	43-15/16	41-7/8	3/16	43	9/16	12	49-7/8	47-1/8	9/16	33-5/16
44	44-1/8	49-5/8	47-3/8	3/16	47	9/16	12	53-1/4	53-7/8	11/16	38-1/8
49	49-1/4	54-3/4	52-1/2	3/16	47	9/16	12	55-3/4	59	11/16	41-3/4
57	57-1/8	62-5/8	59-7/8	3/16	61	9/16	12	65-3/4	66-7/8	11/16	47-5/16
63	63	68-1/2	66-1/4	1/4	61	11/16	16	68-5/8	72-3/4	11/16	51-7/16
71	70-7/8	77-5/8	75	1/4	72	11/16	16	72-3/4	82-5/8	11/16	58-7/16
79	78-3/4	85-9/16	82-7/8	1/4	72	11/16	16	76-5/8	90-1/2	11/16	64

Size	ODP Max. Mtr. Frame	Ship Wt. less Mtr.
35	326T	672
39	365T	867
44	445T	1050
49	445T	1435
57	445T	1875
63	445T	2115
71	445T	3430
79	445T	3780

ALL DIMENSIONS IN INCHES. WEIGHTS IN LBS.

### STANDARD CONSTRUCTION FEATURES:

All aluminum adjustable pitch prop –  
Minimum 3/16" Lorenized steel housing  
with integral straightening vanes –  
Extended lube lines – Regreasable  
bearings in cast pillow block housing.

### ACCESSORIES

1. INLET/OUTLET GUARD
2. INLET/OUTLET COMPANION FLANGE
3. VIBRATION ISOLATORS
4. INLET BELL
5. INLET/OUTLET CONE
6. INSPECTION DOOR
7. SOUND MUFFLER
8. MOTOR COVER
9. BELT GUARD
10. BOMBAY DOORS

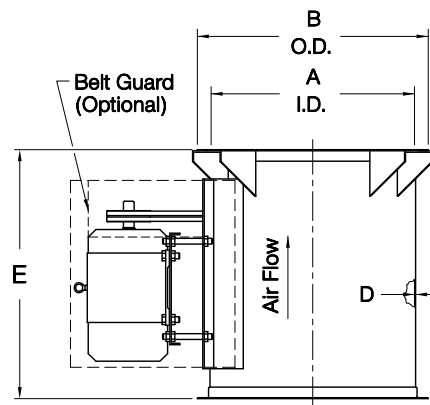
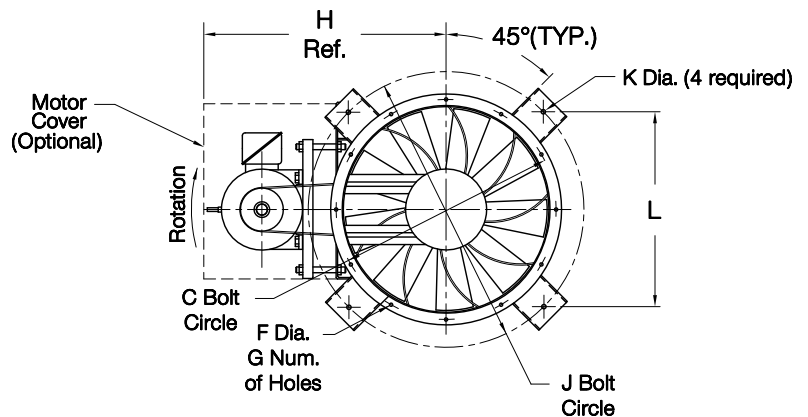

**LARGEST MOTOR SHIPPED MOUNTED:** ODP (OPEN DRIP-PROOF) 25 HP; 2 SP (2 SPEED) 20 HP;  
X-PRF (EXPLOSION PROOF) 20 HP; TEFC (TOTALLY ENCLOSED FAN COOLED) 20 HP.

VA102R03