

DATE: _____
 PROJECT: _____
 LOCATION: _____

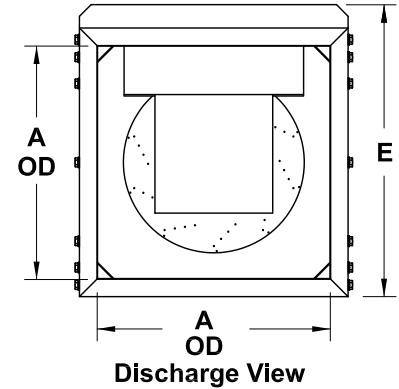

**Centrifugal Square Inline
 Direct Drive
 Preprogrammed EC
 Electronically Commutated
 Vari-Flow® Motor**

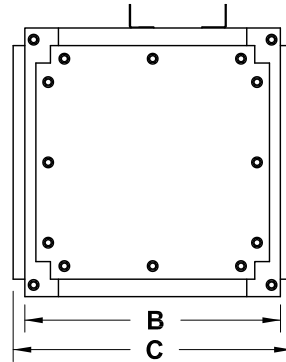
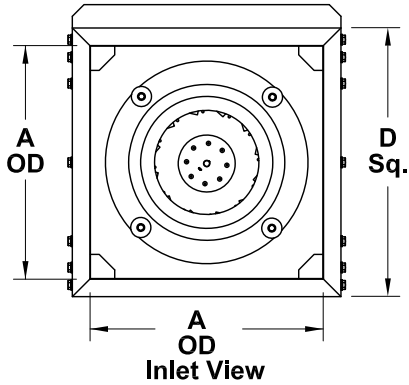

DIMENSION DATA

Size	A	B	C	D Sq.	E	Housing Gauge	Unit Wt.
100	12	20	22	14	15-9/16	18	49
120	16	20	22	18-7/16	20	18	59
135	18	20-1/4	22-1/4	20-3/4	22-5/16	18	78
150	20	21-7/8	23-7/8	23	25-1/16	18	95
165	22	25	27	25-5/16	27-3/8	18	108

ALL DIMENSIONS IN INCHES. WEIGHTS IN LBS., INCLUDING MOTOR.

STANDARD CONSTRUCTION FEATURES:

All aluminum wheel - Galvanized steel housing -
 Three removable access doors - Closed cell neoprene gasketing - Inlet and discharge duct collars - Universal mounting feet - Preprogrammed EC electronically commutated Vari-Flow® motor/drive package - Transit tested packaging.

ACCESSORIES

- SIDE DISCHARGE PACKAGE
- DUAL SIDE DISCHARGE PACKAGE
- DISCONNECT SWITCH
- INSULATED HOUSING
- INLET/OUTLET FLEX DUCT CONNECTOR
- INLET GUARD
- OUTLET GUARD
- FLANGED INLET/FLANGED OUTLET
- INLET/OUTLET COMPANION FLANGE
- GRAVITY BACKDRAFT DAMPER
- MOTORIZED BACKDRAFT DAMPER
- CEILING MOUNTED RUBBER IN SHEAR ISOLATORS
- FLOOR MOUNTED RUBBER IN SHEAR ISOLATORS
- CEILING MOUNTED SPRING ISOLATORS
- FLOOR MOUNTED SPRING ISOLATORS
- LORENIZED COATING

QTY	MARK	CATALOG NUMBER	FAN INFORMATION			MOTOR INFORMATION					ACCESSORIES					
			CFM	SP	RPM	HP	VOLTS	HZ	PH	TYPE						