

This publication contains the installation, operation and maintenance instructions for *Vari-Flow® Air Balance Kit*.



**Carefully read this publication and any supplemental documents prior to any installation or maintenance procedure.**

Loren Cook Product Guide, *Vari-Flow® Motor and Controls*, provides additional information describing the equipment, available accessories and specification data.

For additional safety information, refer to AMCA Publication 410-96, *Safety Practices for Users and Installers of Industrial and Commercial Fans*.

All of the publications listed above can be obtained from:

- [lorencook.com](http://lorencook.com)
- [info@lorencook.com](mailto:info@lorencook.com)
- 417-869-6474 ext. 166

For information and instructions on special equipment, contact Loren Cook Company at 417-869-6474.

### Storage

If the controller is stored for any length of time prior to installation, store controller in the original packaging inside from the weather and keep temperature between -22°F to 122°F (-30°C to 50°C).

### Installation

The VFABK can be mounted two ways. The first option is to mount the VFABK to a DIN rail. The second option is to mount it with four screws through the provided mounting holes. When mounted in a UL Listed enclosure the VFABK is UL listed.

### Location and Maintenance

Consider the following points while choosing a location for the Vari-Flow Air Balance kit.

- Less than 100 feet of wiring to motor.
- Install the controller indoors.
- Do not place the controller on the floor.
- Maintain a temperature between 30°F to 110°F (-1°C to 43°C). A temperature beyond this range may cause condensation and sweating of metal parts.
- Maintain a low humidity, dry, and clean atmosphere. Ensure that the controller is not in the path of blowing dust, rain, or snow.

### Operation

This device contains a 24V power supply required by Vari-Flow Standard EC Motors and other Vari-Flow controllers. Vari-Flow motors operate on a 2-10V signal. Below 2V, the motor stops. The FAN SPEED dial does not indicate voltage, but a range of available voltage from max to min.

Motors with motor-mounted speed control dials should have dials positioned as follows:

- Type M Motors: Fully clockwise (100%)
- Type N Motors: Fully counterclockwise (0%)

Damper control can be achieved by use of the auxiliary contact. Contacts activate at 1.85V. Wire all low voltage components before applying line voltage to motor or controller. Stop position on the left-hand dial sends a 0V signal to the motor. Motor still has power.

### **‘MODE’ Selection Dial**

The ‘MODE’ selection dial has four settings.

- **‘Hand’** allows you to adjust the speed using ‘FAN SPEED’ dial on the VFABK.
- **‘Stop’** turns off the 0-10V motor control signal. Controller and fan still have power.
- **‘Auto’** allows the ‘Remote Control’ to adjust the fan speed.
- **‘Auto Scaled’** uses the FAN SPEED dial to set the max motor speed and the signal from a connected remote speed control device to modulate the motor speed from max to min.

### **Status Indicator Key**

- **Solid Red:** Fan and controller are powered, but control signal to motor is 0V.
- **Solid Green:** The fan is operating at speed set by ‘Remote Control’ signal input.
- **Solid Blue:** The fan has a maximum speed set by ‘FAN SPEED’ dial. The fan speed is then scaled up based on the ‘Remote Control’ signal input.
- **Flashing Blue:** Indicates the ‘MODE’ selection dial is in the ‘Hand’ position, in which the ‘FAN SPEED’ dial on the VFABK is controlling the signal input to the motor.
- **Flashing Blue/Green:** Indicates the ‘MODE’ selection dial is in the ‘Auto’ position, but is not receiving a ‘Remote Control’ input signal.
- **Flashing Red:** Controller does not detect a motor. Check that the motor is properly wired to the Air Balance Kit and that the motor is powered.



**Air Balance Kit**

## Wiring

All wiring should be in accordance with local ordinances and the National Electrical Code, NFPA 70. Ensure the power supply (voltage, frequency, and current carrying capacity of wires) is in accordance with the motor nameplate.



Follow the proper wiring diagram provided with the Air Balance Kit and Remote Control Accessory (if applicable).

## ! WARNING

### Voltage Warning:

Low-voltage control wires and line voltage power wires must not be installed in same conduit. Failure to follow these instructions could result in malfunction or damage.

### Disconnect Warning:

ALWAYS disconnect power prior to working on fan. Failure to comply with these safety precautions could result in property damage, serious injury, or death.

## Wiring Diagram

### Notes

1. For remote on/off control remove jumper and wire to SPST switch or relay
2. Schematic is intended to show interconnection of devices provided by Cook
3. All other devices, wiring, installation and control schemes are the responsibility of others
4. For more information, refer to IOMs and Vari-Flow controls application guide.
5. For detailed wiring see EC motor or Motor controller specific submittals, supplements, and IOMs.
6. Three phase motor controllers will require separate power source.
7. 24V has a combined 0.5A Max output
8. Aux Contact relay rated for 10A @ 24 - 250VAC, 10A @ 30VDC

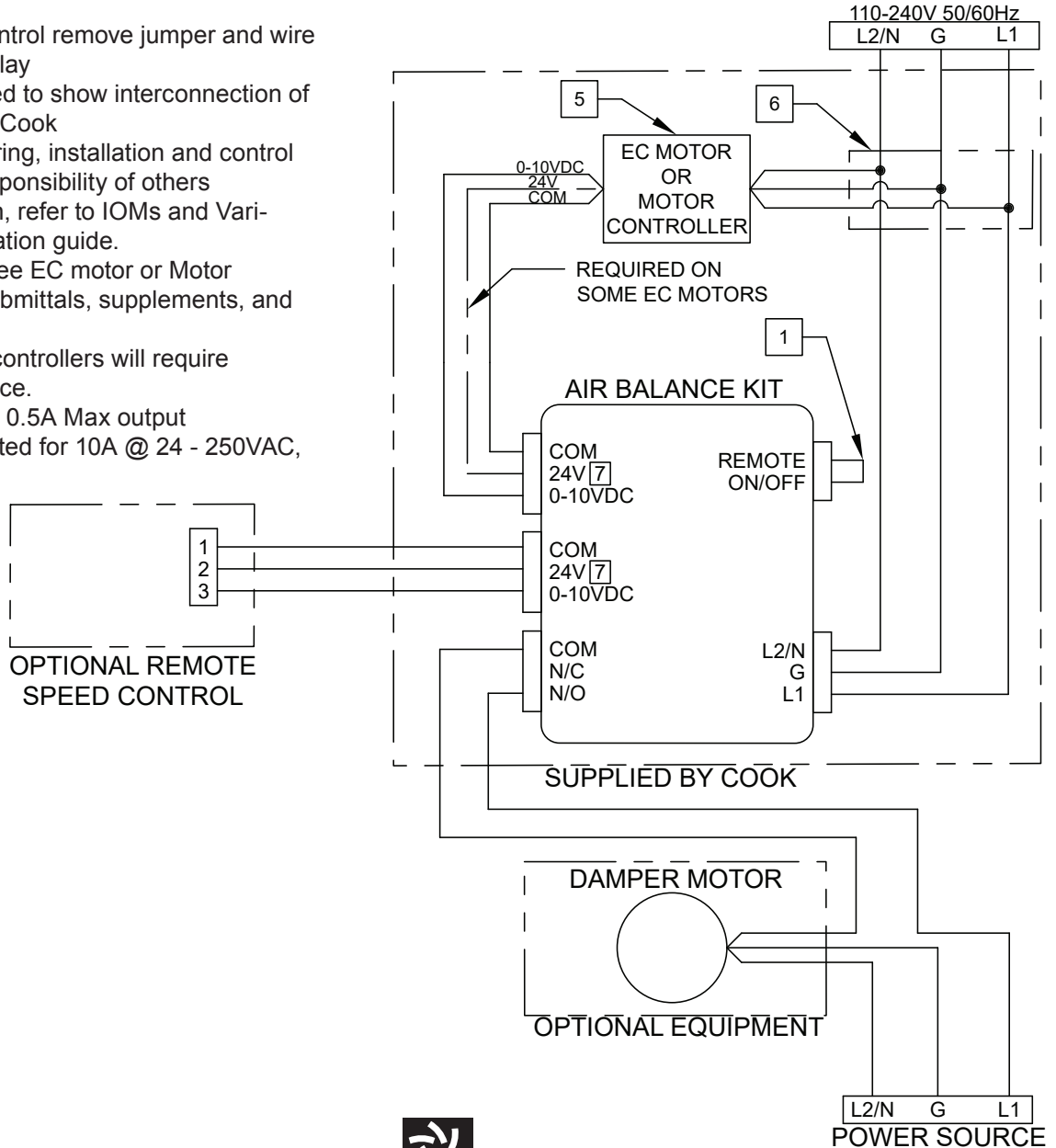

# LOREN COOK COMPANY

Corporate Offices: 2015 E. Dale St. Springfield, MO 65803  
 Phone 417-869-6474 | Fax 417-862-3820 | [lorencook.com](http://lorencook.com)