

MARK: _____
 PROJECT: _____
 DATE: _____

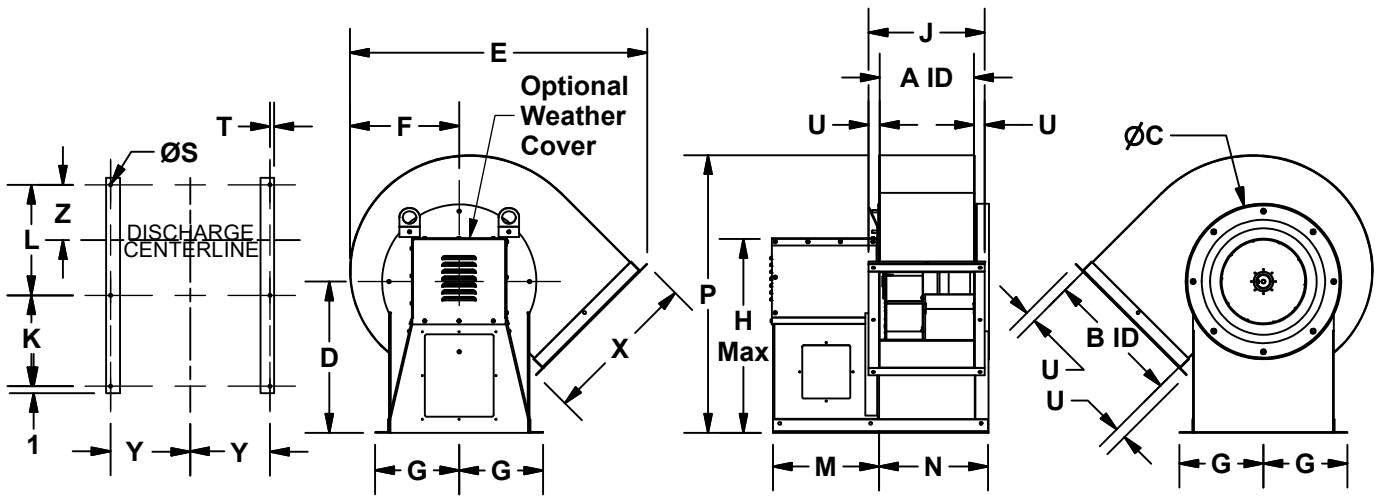

**Centrifugal Blower
 Clockwise Top Angular Down
 Arrangement 4, Class I**



SIZE	A	B	C	D	E	F	G	H	J	K	L	M	N	P
60-100	7 9/16	10 15/16	14 1/8	18	26 11/16	8 7/8	10 3/4	21 13/16	10 3/4	10	9 15/16	12 3/16	9 3/4	28 1/4
120	9 3/16	13 1/8	16 1/8	18	30 1/2	10 11/16	10 3/4	22 9/16	12 3/8	11	11 9/16	13 3/16	11 3/8	30 5/16
135	10 5/16	14 3/4	17 5/8	18	33 5/16	12	10 3/4	22 5/8	13 1/2	11	12 11/16	13 3/16	12 1/2	31 13/16
150	11 7/16	16 7/16	19 1/8	19 1/16	36 13/16	13 5/16	10 3/4	23 11/16	14 5/8	11	13 7/8	13 1/4	13 5/8	34 7/16
165	12 5/8	18 1/16	21 3/16	20 7/16	40	14 5/8	11 3/4	25 1/16	15 13/16	11	15 1/16	13 1/4	14 13/16	37 5/16
180	13 3/4	19 11/16	22 11/16	22 1/16	43 3/8	15 15/16	12 1/4	29 3/16	16 15/16	13 1/4	16 3/16	15 1/2	15 15/16	40 7/16
195	14 15/16	21 5/16	24 3/16	23 11/16	45 15/16	17 1/4	13	30 13/16	18 3/16	13 1/4	17 3/8	15 1/2	17 1/8	43 9/16
210	16 1/16	23	25 15/16	25 3/8	50 1/16	18 5/8	14	35 1/2	19 5/16	17	18 1/2	19 1/4	18 1/4	46 13/16
225	17 3/16	24 5/8	27 7/16	27	52 15/16	19 15/16	14 3/4	35 3/8	20 7/16	17	19 5/8	19 1/4	19 3/8	50
245	18 3/4	26 13/16	29 7/16	29 5/8	57 3/8	21 11/16	15 3/4	39 3/4	23	17	21 3/16	19 1/4	20 15/16	54 5/8
270	20 5/8	29 9/16	31 15/16	32 3/8	62 11/16	23 15/16	17 1/4	43 1/2	24 7/8	20	23 3/16	22 3/8	22 13/16	59 15/16
300	22 15/16	32 13/16	34 15/16	35 5/8	69 7/16	26 9/16	18 1/2	46 3/4	27 3/16	20	25 1/2	22 5/16	25 3/16	66 1/4
330	25 1/4	36 1/8	37 15/16	38 7/8	76 1/4	29 1/4	20 1/2	50 3/4	29 7/16	24	27 7/8	26 3/8	27 1/2	72 5/8

SIZE	S	T	U	X	Y	Z	CPV WT	CPS WT	CPA WT	CPS-A WT	CPA-A WT
60-100	7/16	5/8	1 5/8	14 1/16	10 1/8	4 5/8	94	104	75	-	-
120	7/16	5/8	1 5/8	16 5/16	10 1/8	5 9/16	108	122	84	123	85
135	7/16	5/8	1 5/8	17 15/16	10 1/8	6 1/2	118	134	89	135	91
150	7/16	5/8	1 5/8	19 5/8	10 1/8	7 1/16	136	154	101	155	103
165	7/16	5/8	1 5/8	21 1/4	11 1/8	7 5/8	155	178	114	180	116
180	7/16	5/8	1 5/8	22 7/8	11 5/8	8 1/4	177	219	136	221	139
195	7/16	5/8	1 5/8	24 1/2	12 3/8	8 13/16	200	245	152	247	154
210	7/16	5/8	1 5/8	26 3/16	13 3/8	9 3/8	235	287	177	285	179
225	9/16	5/8	1 5/8	27 13/16	14 1/8	9 15/16	261	316	195	318	200
245	9/16	5/8	2 1/8	31	15 1/8	10 3/4	297	359	219	361	224
270	9/16	1	2 1/8	33 3/4	16 1/4	11 3/4	403	484	308	487	314
300	9/16	1	2 1/8	37	17 1/2	12 7/8	518	637	397	640	403
330	11/16	1	2 1/8	40 5/16	19 1/2	14 1/8	730	870	545	874	553

FOR REDUCED WIDTH WHEELS*

- A' = A - (Unit Size X 0.030 X Percent Reduced)
- J' = J - (Unit Size X 0.030 X Percent Reduced)
- L' = L - (Unit Size X 0.030 X Percent Reduced)
- N' = N - (Unit Size X 0.030 X Percent Reduced)
- Z' = Z - (Unit Size X 0.015 X Percent Reduced)

EXAMPLE: Size 300 Reduced 20%

A' = 22.9375 - (300 X 0.030 X 0.20)

A' = 22.9375 - (1.80)

A' = 21.1375 or 21-1/8

*Percent Reduced = 1 - (Wheel width/100)

*CPV NOT Included

ALL DIMENSIONS IN INCHES. WEIGHTS IN LBS., LESS MOTOR.