



# COOK

# QMXLE/QMXHPLE

MARK: \_\_\_\_\_

PROJECT: \_\_\_\_\_

DATE: \_\_\_\_\_



Laboratory Exhaust  
Mixed-Flow Inline  
Bifurcated Belt Drive  
with 1x2 Mixing Box  
Parallel Bypass

### DIMENSION DATA

Size	A	B	C	D	E	F	G Height	H	J Width	K	L	M	Unit Weight	
													STD	HP
90	120	28	27 3/16	21 3/8	36 11/16	38	10 9/16	8	19 3/4	63 5/16	64	36 1/2	1507	1517
120	120	28	27 3/16	25 5/8	40 7/16	39	12 13/16	8	19 3/4	63 5/16	64	36 1/2	1691	1695
135	120	28	27 1/8	27 3/4	41 5/8	40	14 13/16	8	18 9/16	63 5/16	64	36 9/16	2125	2128
150	120	30	29 1/8	29 9/16	44 1/8	43	16 9/16	8	20 9/16	67 5/16	68	38 9/16	2238	2241
165	120	32	31 1/8	31 11/16	45 1/2	46	18 5/16	8	22 9/16	71 5/16	72	40 9/16	2508	2533
180	120	34	33 1/8	34 1/16	48	48	19 1/16	8	24 9/16	83 5/16	84	50 9/16	2910	2931
202	125 13/16	38	36 15/16	37 15/16	51 7/8	54	22 9/16	8	28 9/16	89 1/8	90	52 9/16	3453	3478
225	134 3/4	42	40 15/16	41 1/8	58	59	22 9/16	9	30 9/16	92 1/8	93	51 9/16	3918	3979
245	146 1/16	44	42 15/16	43 7/16	60 5/8	62	24 13/16	9	32 9/16	107 1/8	108	64 9/16	4507	4550
270	155 5/16	48	46 15/16	47	64 5/8	67	26 9/16	9	36 9/16	111 1/8	112	64 9/16	5070	5102
300	171 1/16	52	50 15/16	51 3/16	69 7/16	72	29 13/16	9	40 9/16	131 1/8	132	80 9/16	6102	6142
330	185 3/4	56	54 13/16	55 15/16	75 15/16	78	33	9	44 1/2	135 1/8	136	80 9/16	6631	6683
365	203 3/16	62	60 3/4	61 15/16	81 5/8	86	35	11	46 3/8	158	159	97 3/4	8932	9044
402	222	67	65 5/8	67 1/8	89 5/16	94	41 1/4	11	50 5/16	163	164	97 3/4	10633	10748
445	248 1/8	74	72 5/8	73 1/4	96 1/8	106	47	13	53 5/16	170	171	97 3/4	12530	12629
490	271	80	78 1/2	79 9/16	104 1/16	117	57 1/4	13	59 1/8	191	192	112 7/8	20000	20149

ALL DIMENSIONS IN INCHES. WEIGHTS IN LBS., LESS MOTOR.  
 \* RECOMMENDED CURB OUTSIDE SQUARE DIMENSION.  
 \*\* MIXING BOX INSIDE SQUARE DIMENSION.  
 \*\*\* DIMENSION IS FROM THE BOTTOM OF THE CURB CAP TO THE TOP OF THE CURB.

### STANDARD CONSTRUCTION FEATURES:

High efficiency, non-overloading mixed-flow welded wheel - Minimum 14 gauge steel welded bifurcated housing - Welded aerodynamic straightening vanes - Hinged Discharge Damper - Phenolic epoxy powder with UV protection (Light Gray) - L10/40k Concentric locking regreasable bearings - Bolted access door - Lifting lugs - Fan drain - Weather cover - Reinforced curb cap - Stainless Steel shaft - Stainless Steel hardware - Stainless Steel extended lube lines - NEMA 3R disconnect mounted and pre-wired - 1.5 Service factor drives - Designed to withstand 125 mph wind\*\*\*\*

**BYPASS PLENUM:** Single wall welded steel construction with inner angle frame - Bottom inlet location - Phenolic epoxy powder with UV protection (Light Gray) - Plenum drain - Bolted access door - Painted aluminum bypass damper with manual hand quadrant - Painted aluminum isolation damper with 2 position actuator - Weather hood - Stainless steel birdscreen - Stainless Steel hardware - Designed to withstand 125 mph\*\*\*\*

### OPTIONAL FEATURES SHOWN:

Heavy Duty Lab Exhaust Curb  
 Side Intake Opening  
 Damper Actuator

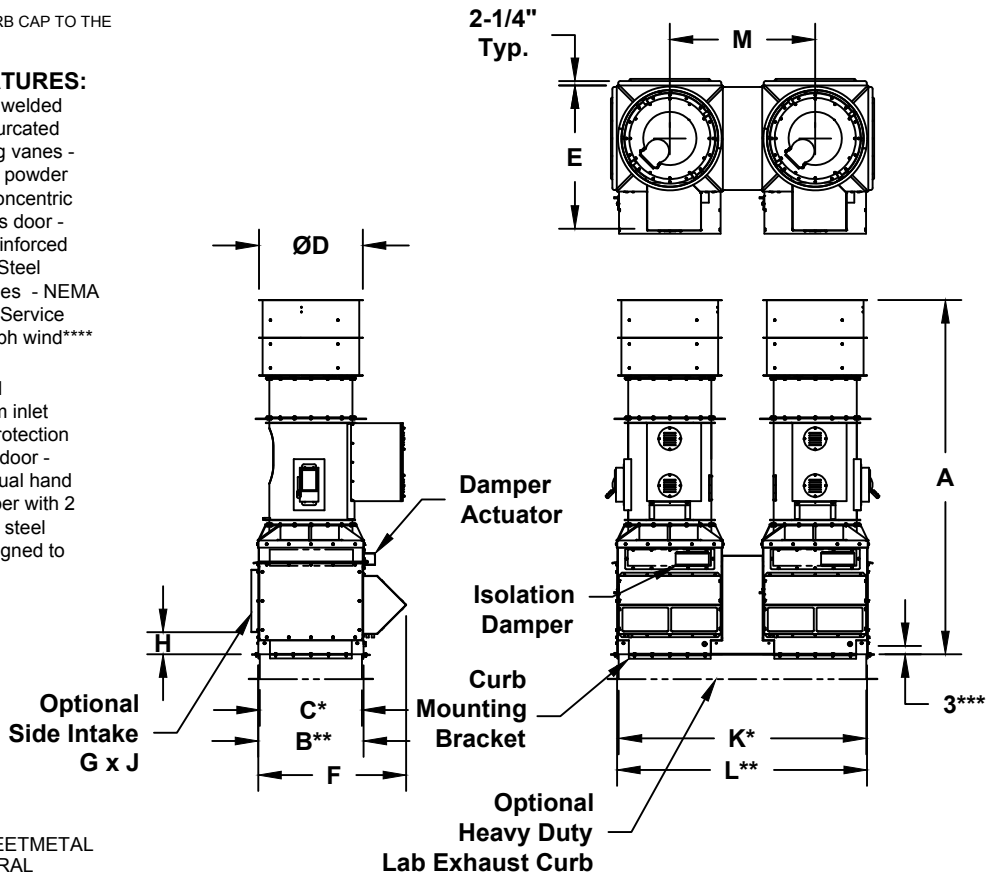

NOT INTENDED TO BE SUPPORTED BY TRADITIONAL SHEETMETAL ROOF CURB, BUT BY INTEGRAL MEMBERS OF ROOF STRUCTURE.

\*\*\*\* WINDLOAD RATING DEPENDANT ON ADEQUATE ATTACHMENT TO ROOF STRUCTURE.