

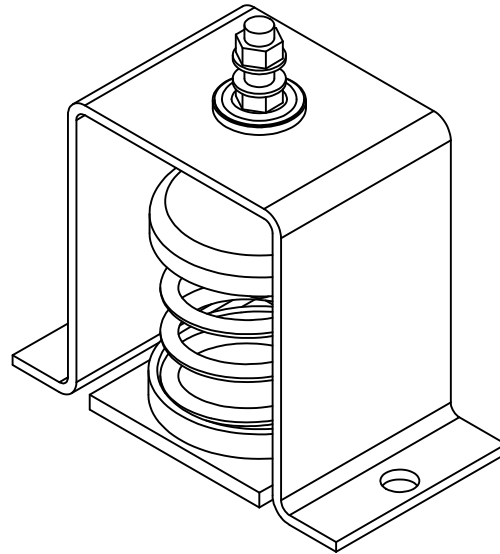

COOK Seismic Restrained Spring

MARK: _____
 PROJECT: _____
 DATE: _____

**Seismic Restrained
 Spring Isolator
 Floor Mounted
 1" Deflection**

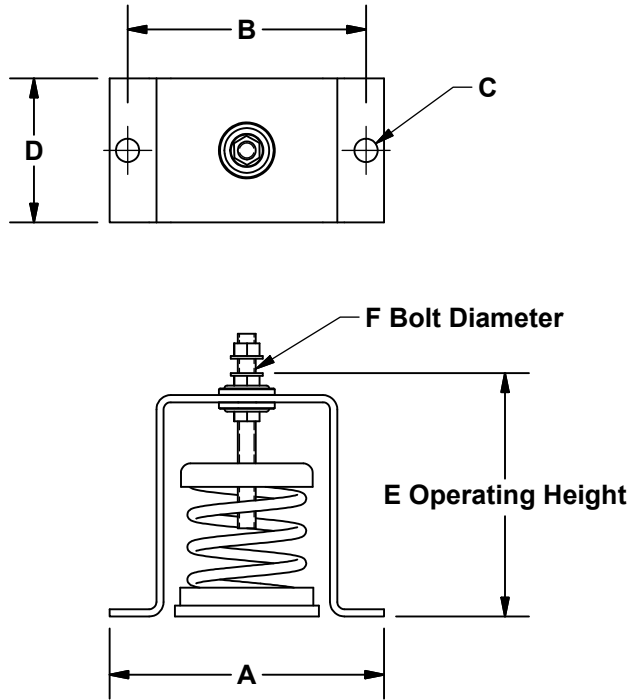

DIMENSION DATA

LC Model	Mfg.	Mfg. Model	Rated Deflect	Rated Load	Spr. Rate (lbs/in)	A	B	C	D	E	F	Unit Wt.
SRS-100	KNC	FHS-1-100	1.00	100	100	9-17/32	7-25/32	13/16	5	7-9/16	5/8	8
SRS-250	KNC	FHS-1-250	1.79	250	140	9-17/32	7-25/32	13/16	5	7-9/16	5/8	8
SRS-450	KNC	FHS-1-450	1.54	450	293	9-17/32	7-25/32	13/16	5	7-9/16	5/8	8
SRS-625	KNC	FHS-1-625	1.44	625	435	9-17/32	7-25/32	13/16	5	7-9/16	5/8	8
SRS-800	KNC	FHS-1-800	1.31	800	611	9-17/32	7-25/32	13/16	5	7-9/16	5/8	8
SRS-1000	KNC	FHS-1-1000	1.15	1000	870	9-17/32	7-25/32	13/16	5	7-9/16	5/8	8
SRS-1250	KNC	FHS-1-1250	1.09	1250	1147	9-17/32	7-25/32	13/16	5	7-9/16	5/8	8
SRS-1700	KNC	FHS-1-1700	.95	1700	1790	9-17/32	7-25/32	13/16	5	7-9/16	5/8	8
SRS-2200	KNC	FHS-1-2200	1.00	2200	2200	9-17/32	7-25/32	13/16	5	7-9/16	5/8	8
SRS-2465*	KNC	FHS-1-2465	1.00	2465	2465	9-17/32	7-25/32	13/16	5	7-9/16	5/8	9
SRS-2865*	KNC	FHS-1-2865	1.00	2865	2865	9-17/32	7-25/32	13/16	5	7-9/16	5/8	9
SRS-3500*	KNC	FHS-1-3500	1.00	3500	3500	9-17/32	7-25/32	13/16	5	7-9/16	5/8	9

ALL DIMENSIONS IN INCHES. WEIGHTS IN LBS.
 ALL ISOLATORS LISTED ARE DESIGNED TO PROVIDE A MINIMUM OF 50% OVERLOAD CAPACITY.
 *ISOLATORS WITH WELDED GUSSETS.