



# COOK

# Roof Exhauster VAHB

DATE: \_\_\_\_\_

PROJECT: \_\_\_\_\_

LOCATION: \_\_\_\_\_



**Fixed Pitch Vane Axial  
Roof Exhauster  
Belt Drive  
Arrangement 9**

**DIMENSION DATA**

Size	A	B	T Sq.	ODP Max. Mtr. Frame	Ship Wt. less Mtr.
12	34	32	22	145T	188
14	37	36	24	182T	232
18	51	41-1/4	28	215T	305
21	53	47-1/2	32	254T	437
26	55	52-1/2	36	256T	611
29	59	61-1/2	42	284T	897
36	71	69-1/2	48	326T	1173
42	79	77-1/2	54	364T	1626
48	97-1/2	83-1/8	58-1/4	365T	2164
54	103-1/2	91-5/8	64-1/4	405T	2416
60	110-1/2	100-1/8	70-1/4	444T	2731

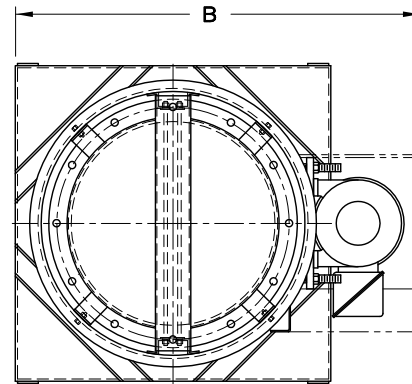

ALL DIMENSIONS IN INCHES. WEIGHTS IN LBS.

**STANDARD CONSTRUCTION FEATURES:**

All aluminum cast prop – Minimum 10 ga.  
Lorenized steel housing with integral straightening vanes – Extended lube lines – Regreasable bearings in cast pillow block housing – Integral lifting lugs.

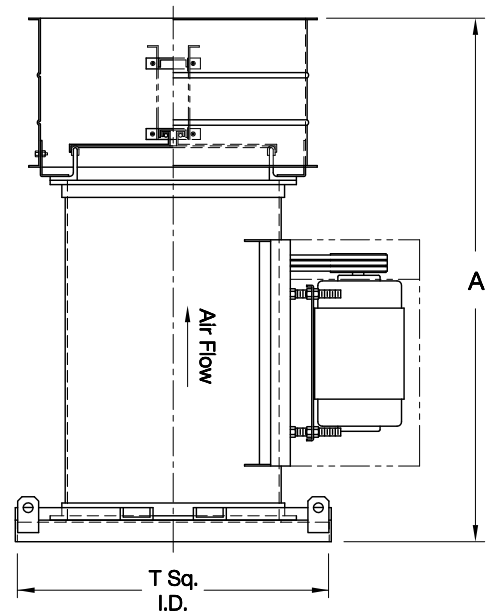

**ACCESSORIES**

1. INLET/OUTLET GUARD
2. INSPECTION DOOR
3. MOTOR COVER
4. HUB COVER
5. BOMBAY DOORS (N/A 12 & 14)

QTY	MARK	CATALOG NUMBER	FAN INFORMATION			MOTOR INFORMATION					ACCESSORIES	
			CFM	SP	RPM	HP	VOLTS	HZ	PH	TYPE		

**LARGEST MOTOR SHIPPED MOUNTED:** ODP (OPEN DRIP-PROOF) 25 HP; 2 SP (2 SPEED) 20 HP; X-PRF (EXPLOSION PROOF) 20 HP; TEFC (TOTALLY ENCLOSED FAN COOLED) 20 HP.

**VA099R03**