

MARK: _____
 PROJECT: _____
 DATE: _____

Accessory Data Sheet Centrifugal Blowers with Curb Cap & Inlet Box

STANDARD CONSTRUCTION FEATURES:
 Heavy gauge steel construction - Reinforcement angle - Angle frame around Inlet Box duct opening.

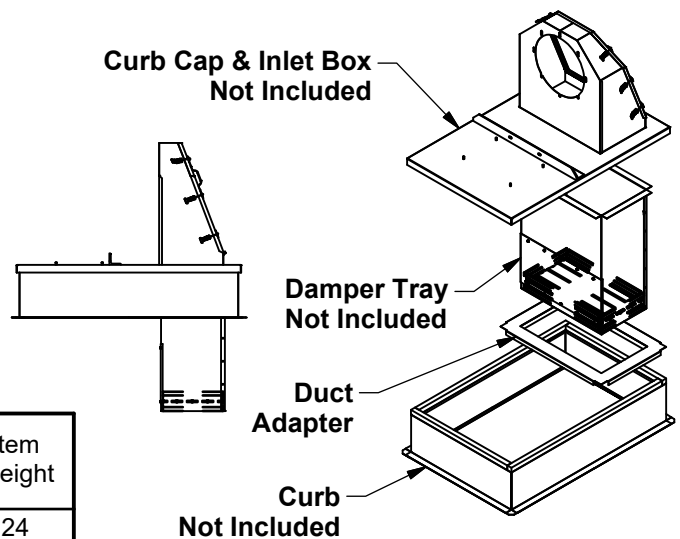
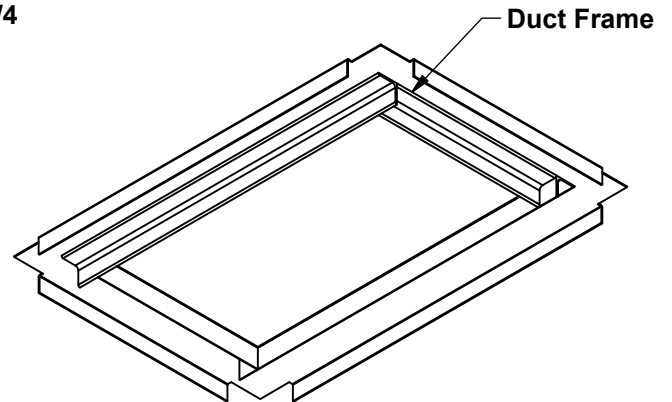
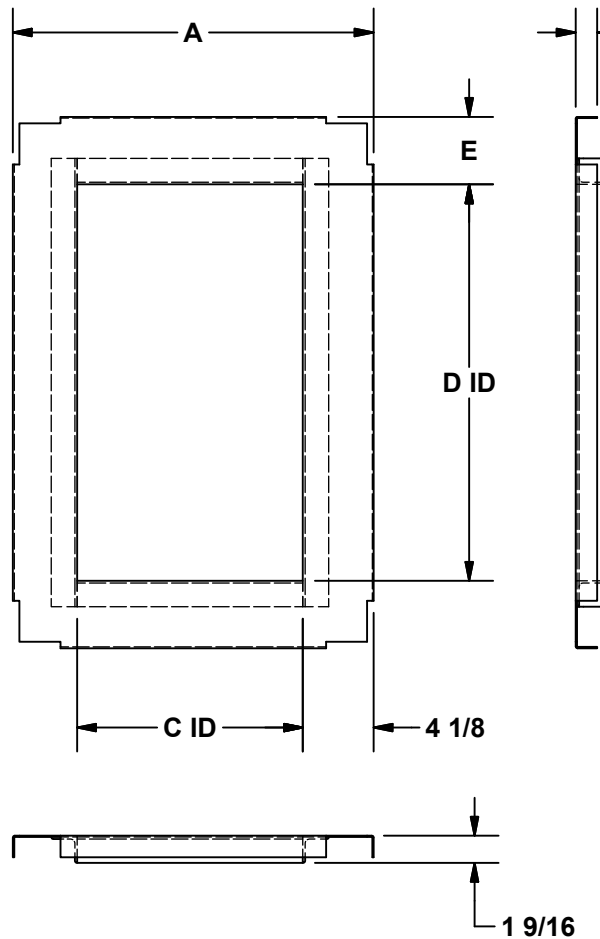

DIMENSION DATA

Size	A	B	C	D	E	Item Weight
60-100	20 7/8	30 3/4	13 1/16	22 15/16	3 17/32	24
120	20 7/8	30 3/4	13 1/16	22 15/16	3 17/32	25
135	22 1/2	32 3/4	14 5/16	25 5/16	3 11/32	29
150	23 3/4	35 3/4	15 11/16	27 11/16	3 21/32	32
165	24 3/4	37 3/4	16 15/16	29 15/16	3 17/32	36
180	25 3/4	39 3/4	18 5/16	32 5/16	3 11/32	38
195	27 3/4	42 3/4	19 11/16	34 11/16	3 21/32	46
210	30 1/8	46 3/4	21 5/16	37 15/16	4 1/32	52
225	31 1/8	48 3/4	22 13/16	40 7/16	3 25/32	55
245	32 1/4	50 3/4	24 5/16	42 13/16	3 19/32	59

ALL DIMENSIONS IN INCHES. WEIGHTS IN LBS.

Typical Installation

Note: Consult with local code authority regarding the use of this item in restaurant exhaust (NFPA96/UL762) applications.