



COOK

Isolation Damper

DATE: _____

PROJECT: _____

LOCATION: _____

Accessory Data Sheet

Isolation Damper

Low Leakage Class 1A Rated

for CAVP Mixing Box

**Aluminum
Class III**

STANDARD CONSTRUCTION FEATURES:

- Frame: 5" x 1" x 6063T5 extruded hat channel with .125" minimum wall thickness
- Blades: 6" wide, 6063T5 heavy gauge extruded aluminum, airfoil shape. Opposed blade standard.
- Seals: Synthetic polymer blade edge seals and flexible SS compressible jamb seals.
- Bearings: Molded synthetic.
- Linkage: Concealed in frame.
- Axles: 1/2" plated steel hex.
- Temperature Limits: -72°F and +275°F.
- Actuator out of Airstream, 1 Actuator per panel, protected from weather.
- Sizes 90-202 available in 115v (230, 460, and 575vac with transformer)
- Sizes 225-600 available in 24-124vdc or 24-230vac (460 and 575vac with transformer)
- Power Open/Spring Close (Reversible).
- Finish: Air-dry enamel coating to match fan color.

OPTIONAL CONSTRUCTION FEATURES:

- Air-dry epoxy finish.
- Actuator by others, damper provided with manual hand quadrant.
- Pneumatic actuator.

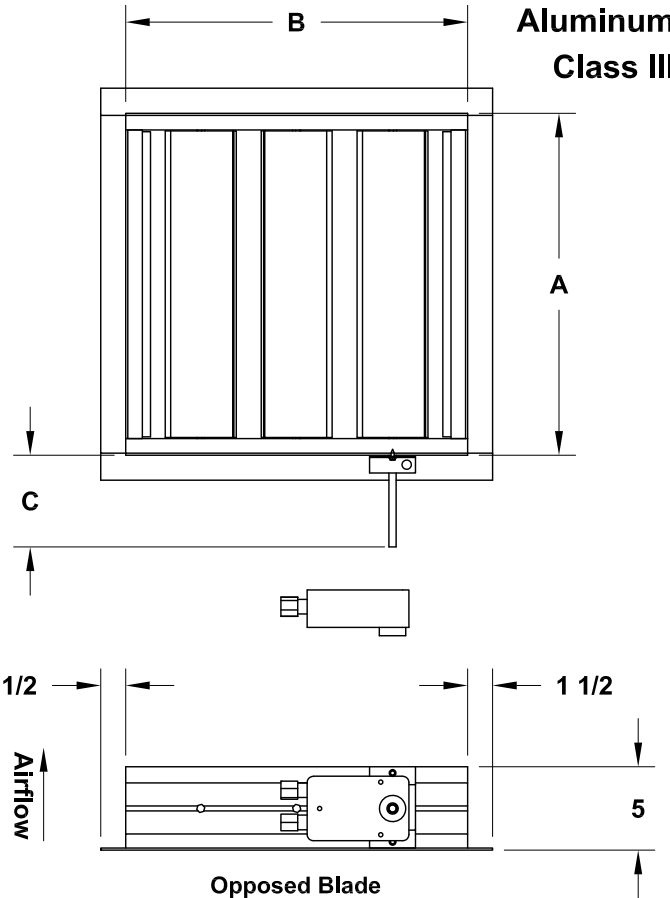
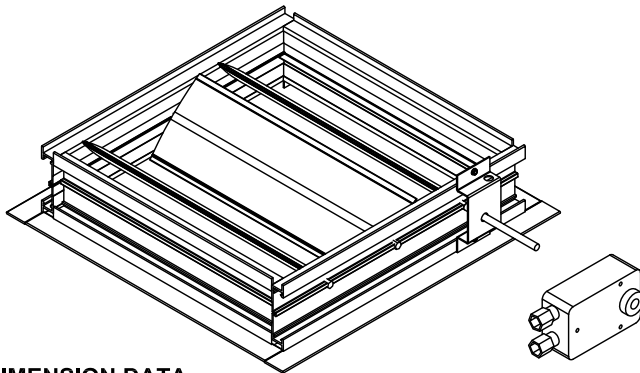

DIMENSION DATA

Qty	Mark	Size	A	B	C	No. Panels	Actuator Model	No. Actuators	Unit Wt.
		120	16-3/4	16-3/4	7	1	LF120-S	1	14
		135	18-1/4	18-1/4	7	1	LF120-S	1	16
		150	19-3/4	19-3/4	7	1	LF120-S	1	18
		165	21-3/4	21-3/4	7	1	LF120-S	1	21
		180	23-1/4	23-1/4	7	1	LF120-S	1	23
		195	25	25	7	2	LF120-S	2	29
		210	26-1/2	26-1/2	7	1	NFBUP-S	2	32
		225	28	28	7	1	NFBUP-S	2	37
		245	30	30	7	1	NFBUP-S	2	41
		270	32-1/2	32-1/2	7	1	NFBUP-S	2	46
		300	35-1/2	35-1/2	7	1	AFBUP-S	2	54
		330	38-1/2	38-1/2	7	2	AFBUP-S	2	61
		365	42	42	7	2	AFBUP-S	2	76
		402	46	46	7	2	AFBUP-S	2	89
		445	50-1/4	50-1/4	10	3	AFBUP-S	1	96
		490	55-1/2	55-1/2	13	3	AFBUP-S	1	116
		540	60-3/4	60-3/4	17	3	AFBUP-S	2	144
		600	66-3/4	66-3/4	17	3	AFBUP-S	2	171
		660	73	73	17	8	AFBUP-S	4	215
		730	80	80	17	8	AFBUP-S	4	253

ALL DIMENSIONS IN INCHES. WEIGHTS IN LBS. WEIGHT INCLUDES ACTUATOR.

X0242R00