



COOK

BDI-VC/BDMI-VC

DATE: _____

PROJECT: _____

LOCATION: _____

Automatic/Motorized Backdraft Damper ERV Return Air Intake Arrangement V & C

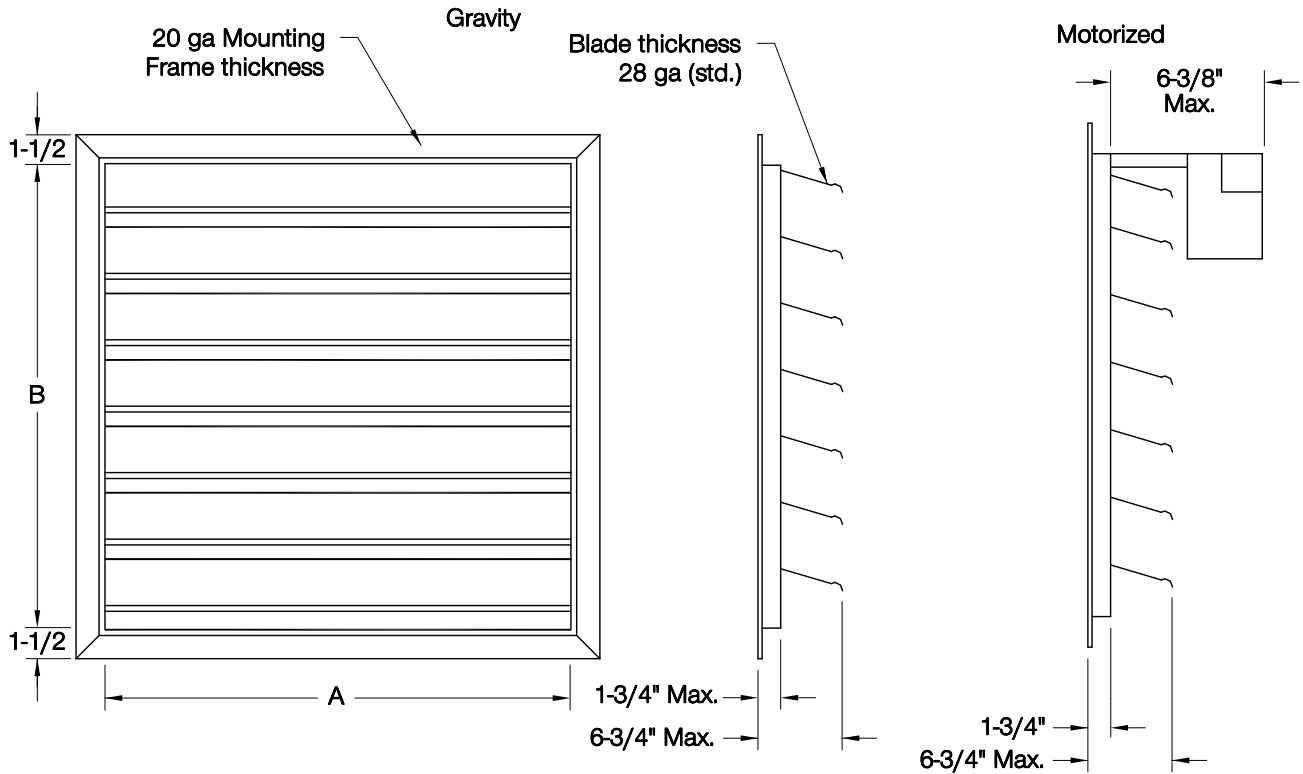

DIMENSION DATA

Qty	Mark	Motorized Model No.	Gravity Model No.	Unit Size	A	B	Unit Weight
		BDMI-VC-1500	BDI-VC-1500	1500	18-1/2	12-1/2	6
		BDMI-VC-2500	BDI-VC-2500	2500	21-1/2	12-1/4	7
		BDMI-VC-3500	BDI-VC-3500	3500	22-1/2	16	9
		BDMI-VC-4500	BDI-VC-4500	4500	25-1/2	18-1/4	12
		BDMI-VC-5500	BDI-VC-5500	5500	25-1/2	18-1/4	12
		BDMI-VC-7000	BDI-VC-7000	7000	31-1/2	23-1/2	19
		BDMI-VC-8500	BDI-VC-8500	8500	31-1/2	23-1/2	19
		BDMI-VC-10000	BDI-VC-10000	10000	34	32-1/2	28

ALL DIMENSIONS IN INCHES.

NOTES:

- 1) ADD 2# TO SHIPPING WT FOR EACH MOTOR ON MOTORIZED UNITS.