



COOK

QMXDLE/QMXHPDLE

MARK: _____

PROJECT: _____

DATE: _____



Laboratory Exhaust
Mixed-Flow Inline
Bifurcated Direct Drive
with 1x2 Mixing Box
Parallel Bypass

DIMENSION DATA

Size	A	B	C	D	F	G Height	H	J Width	K	L	M	Unit Weight	
												STD	HP
150	120	30	29 1/8	29 9/16	43	16 9/16	8	20 9/16	67 5/16	68	38 9/16	1992	1993
165	120	32	31 1/8	31 11/16	46	18 5/16	8	22 9/16	71 5/16	72	40 9/16	2120	2124
180	120	34	33 1/8	34 1/16	48	19 1/16	8	24 9/16	83 5/16	84	50 9/16	2294	2299
202	125 13/16	38	36 15/16	37 15/16	54	22 9/16	8	28 9/16	89 1/8	90	52 9/16	2719	2721
225	134 3/4	42	40 15/16	41 1/8	59	22 9/16	9	30 9/16	92 1/8	93	51 9/16	3232	3240
245	146 1/16	44	42 15/16	43 7/16	62	24 13/16	9	32 9/16	107 1/8	108	64 9/16	3633	3643
270	155 5/16	48	46 15/16	47	67	26 9/16	9	36 9/16	111 1/8	112	64 9/16	4038	4039
300	171 1/16	52	50 15/16	51 3/16	72	29 13/16	9	40 9/16	131 1/8	132	80 9/16	4872	4873
330	185 3/4	56	54 13/16	55 15/16	78	33	9	44 1/2	135 1/8	136	80 9/16	5041	5045
365	203 3/16	62	60 3/4	61 15/16	86	35	11	46 3/8	158	159	97 3/4	6420	6426
402	222	67	65 5/8	67 1/8	94	41 1/4	11	50 5/16	163	164	97 3/4	7923	7919
445	248 1/8	74	72 5/8	73 1/4	106	47	13	53 5/16	170	171	97 3/4	9926	9912
490	271	80	78 1/2	79 9/16	117	57 1/4	13	59 1/8	191	192	112 7/8	14576	14572

ALL DIMENSIONS IN INCHES. WEIGHTS IN LBS., LESS MOTOR.
 * RECOMMENDED CURB OUTSIDE SQUARE DIMENSION.
 ** MIXING BOX INSIDE SQUARE DIMENSION.
 *** DIMENSION IS FROM THE BOTTOM OF THE CURB CAP TO THE TOP OF THE CURB.

STANDARD CONSTRUCTION FEATURES:

High efficiency, non-overloading mixed-flow welded aluminum wheel - Minimum 14 gauge steel welded bifurcated housing - Welded aerodynamic straightening vanes - Hinged discharge damper with windband - Phenolic epoxy powder with UV protection (Light Gray) - Bolted access door - Lifting lugs - Fan drain - Weather cover - Reinforced curb cap - Stainless Steel hardware - Stainless Steel extended lube lines when applicable - NEMA 3R disconnect mounted and pre-wired - Designed to withstand 125 mph wind****

BYPASS PLENUM: Single wall welded steel construction with inner angle frame - Bottom inlet location - Phenolic epoxy powder with UV protection (Light Gray) - Plenum drain - Bolted access door - Painted aluminum bypass damper with manual hand quadrant - Painted aluminum isolation damper with 2 position actuator - Weather hood - Stainless steel birdscreen - Stainless Steel hardware - Designed to withstand 125 mph wind****

OPTIONAL FEATURES SHOWN:

Heavy Duty Lab Exhaust Curb
 Side Intake Opening

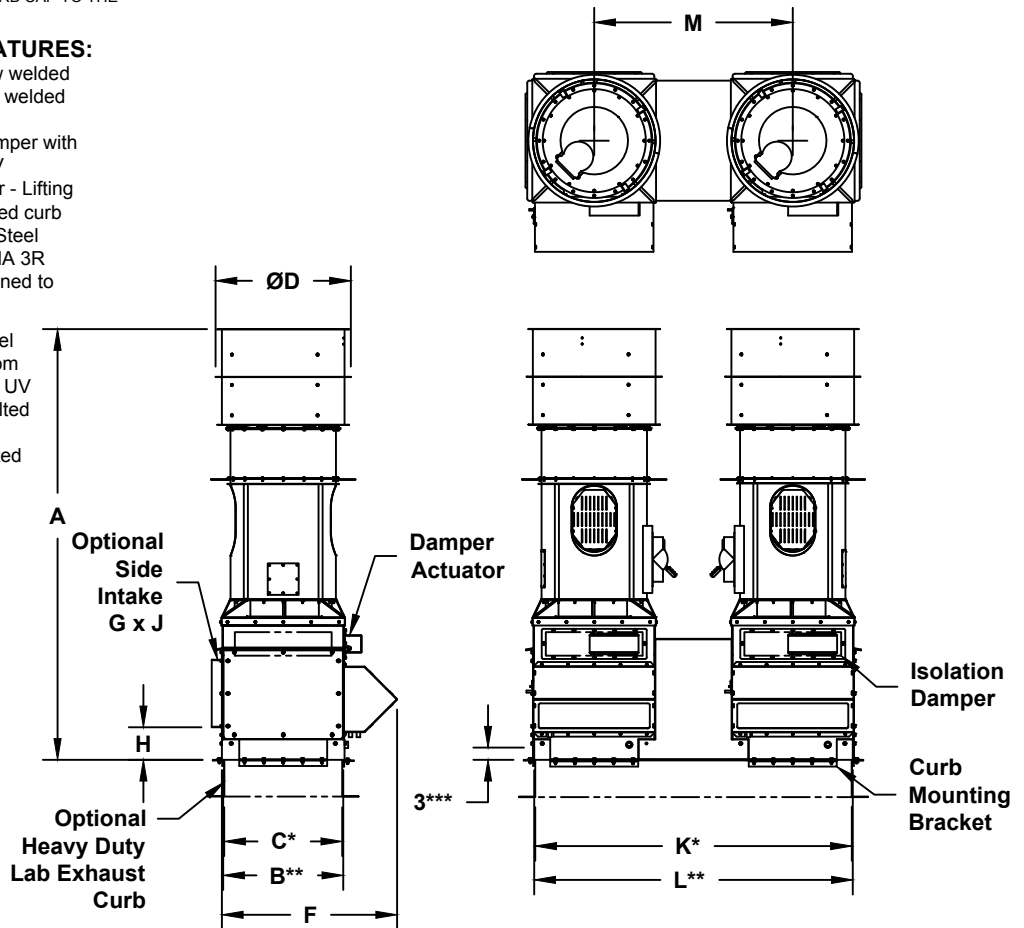

NOT INTENDED TO BE
 SUPPORTED BY TRADITIONAL SHEETMETAL
 ROOF CURB, BUT BY INTEGRAL
 MEMBERS OF ROOF STRUCTURE.

**** WINDLOAD RATING DEPENDANT ON ADEQUATE
 ATTACHMENT TO ROOF STRUCTURE.

TM046R00