



COOK

Discharge Shutter

DATE: _____

PROJECT: _____

LOCATION: _____

Accessory Data Sheet
Aluminum Construction
IMH

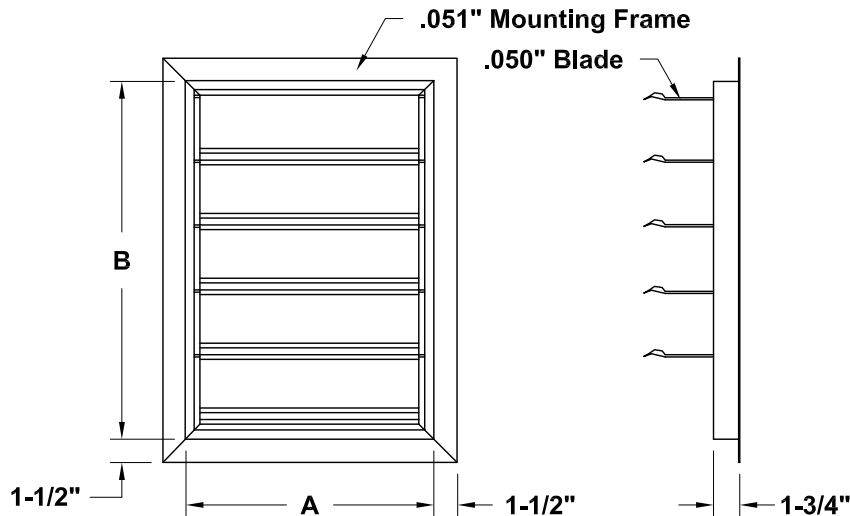

DIMENSION DATA

Size	Shutter Model Number	A	B	Ship Wt.
70	ADSH-70MH	5-7/8	6-5/8	2
90	ADSH-90MH	7-1/2	8-7/16	3
110	ADSH-110MH	9-1/8	10-3/8	3
130	ADSH-130MH	10-7/8	12-3/16	4
150	ADSH-150MH	12-9/16	14-1/16	4
170	ADSH-170MH	14-1/4	16	4
190	ADSH-190MH	15-7/8	17-13/16	5
210	ADSH-210MH	17-9/16	19-3/4	6
230	ADSH-230MH	19-1/4	21-5/8	6
260	ADSH-260MH	21-3/4	24-7/16	7
290	ADSH-290MH	24-1/4	27-5/16	8

ALL DIMENSIONS IN INCHES. WEIGHTS IN LBS.

NOTES: For clean air applications only.

Maximum velocity 2500 FPM. Motor operated dampers required for velocities below 400 FPM.

STANDARD CONSTRUCTION FEATURES:

Blades are extruded 6063 T6 aluminum. Blades have vinyl edge gasket. Damper frame is extruded 6063 T6 aluminum. Extruded aluminum blade link bar connects each blade for uniform blade positioning. Blades pivot on full width extruded aluminum blade hanger for added strength.