

This publication contains the installation, operation and maintenance instructions for standard units of the QMX: *Mixed Flow Inline*.

- QMX
- QMXHPD
- QMXHP
- QMXE
- QMXS
- QMXHPE
- QMXHPS
- QMXU
- QMXHPU
- QMXLE
- QMXHPLE
- QMXD
- QMXXP
- QMXVP
- QMXHPVP



Carefully read this publication and any supplemental documents prior to any installation or maintenance procedure.

Cook website provides additional information describing the equipment, fan performance, available accessories and specification data.

For additional safety information, refer to AMCA Publication 410-96, *Safety Practices for Users and Installers of Industrial and Commercial Fans*.

All of the publications listed above can be obtained from:

- lorencook.com
- info@lorencook.com
- 417-869-6474 ext. 166

For information and instructions on special equipment, contact Loren Cook Company at 417-869-6474.

Receiving and Inspection

Carefully inspect the fan and accessories for any damage and shortage immediately upon receipt of the fan.

- Turn the wheel by hand to ensure it turns freely and does not bind
- Inspect inlet vane dampers (if supplied) for free operation of all moving parts
- Record on the *Delivery Receipt* any visible sign of damage

Handling

Lift the fan by lifting lugs.

NOTICE! Never lift by the shaft, motor or housing.



QMX

! WARNING

Rotating Parts & Electrical Shock Hazard:

Fans should be installed and serviced by qualified personnel only.

Disconnect electric power before working on unit (prior to removal of guards or entry into access doors).

Follow proper lockout/tagout procedures to ensure the unit cannot be energized while being installed or serviced.

A disconnect switch should be placed near the fan in order that the power can be swiftly cut off, in case of an emergency and in order that maintenance personnel are provided complete control of the power source.

Grounding is required. All field-installed wiring must be completed by qualified personnel. All field installed wiring must comply with National Electric Code (NFPA 70) and all applicable local codes. Ensure the power supply (voltage, frequency and current carrying capacity of wires) is in accordance with the motor nameplate.

Fans and blowers create pressure at the discharge and vacuum at the inlet. This may cause objects to get pulled into the unit and objects to be propelled rapidly from the discharge. The discharge should always be directed in a safe direction and inlets should not be left unguarded. Any object pulled into the inlet will become a projectile capable of causing serious injury or death.

When air is allowed to move through a non-powered fan, the impeller can rotate, which is referred to as windmilling. Windmilling will cause hazardous conditions due to unexpected rotation of components. Impellers should be blocked in position or air passages blocked to prevent draft when working on fans.

Friction and power loss inside rotating components will cause them to be a potential burn hazard. All components should be approached with caution and/or allowed to cool before contacting them for maintenance.

Under certain lighting conditions, rotating components may appear stationary. Components should be verified to be stationary in a safe manner, before they come into contact with personnel, tools or clothing.

Failure to follow these instructions could result in death or serious injury.

The attachment of roof mounted fans to the roof curb as well as the attachment of roof curbs to the building structure must exceed the structural requirements based on the environmental loading derived from the applicable building code for the site. The local code official may require variations from the recognized code based on local data. The licensed engineer of record will be responsible for prescribing the correct attachment based on construction materials, code requirements and environmental effects specific to the installation.

Storage

If the fan is stored for any length of time prior to installation, completely fill the bearings with grease or moisture-inhibiting oil (refer to *Lubrication*, page 6). Store the fan in its original crate and protect it from dust, debris and weather.

- Cover the inlet, outlet and belt tunnel opening to prevent the accumulation of dirt and moisture in the housing
- Periodically rotate the wheel and operate inlet vane dampers (if supplied) to keep a coating of grease on all internal bearing parts
- Periodically inspect the unit to prevent damaging conditions

Installation

QMX, QMX-HP and QMX-XP can be mounted horizontally or vertically to a floor or a ceiling in various motor positions and discharges. (See Mounting Detail) QMXU, QMXHPU, QMXE, QMXHPE, QMXS and QMXHPS are all designed to be roof mounted on typical roof curbs. The QMX-LE or QMX-VP units, however, should not be mounted on sheet metal roof curbs, but supported by integral members of the roof structure, designed and constructed by others per local requirements and environments.

Most motors are shipped mounted on the fans with belts and drives installed. However, extremely heavy motors are shipped separately, and some motors are shipped separately due to height limitations. These motors and drives will require field installation.

Note: On direct drive units, make sure the motor is sitting on top of the motor plate as shown in the mounting detail. All QMXD Horizontal Ceiling (HC) fans will require the housing to be rotated by following the steps given below.

1. Unbolt the base from housing at inlet and outlet ends.
2. Rotate the housing so that motor is sitting on top of the motor plate as shown in the direct drive ceiling mount details.
3. Bolt together the base and housing at both inlet and outlet ends.

Mounting Detail

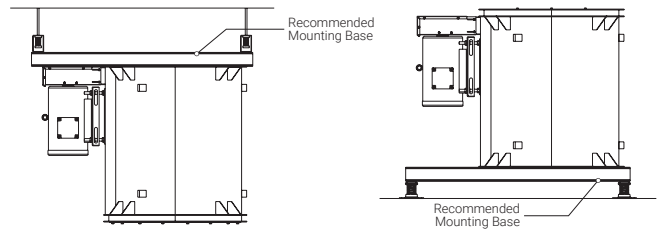
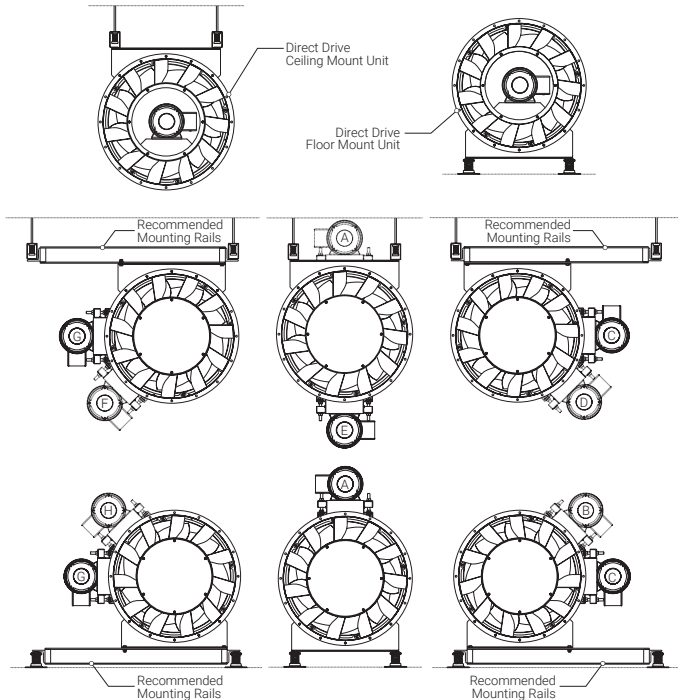

NOTICE! Although a certain amount of vibration is inherent in operating fans, extreme vibration is a serious problem that may cause structural and mechanical failure.

Isolation Installation

To help prevent vibration and noise from being transferred to the building, isolators are recommended.

Floor Mounted Spring Isolators

4. Mount fan on isolation base or rails (if supplied).
5. Elevate fan (or isolation base) to operating height and insert blocks to hold in position.
6. Position isolators under the fan and vertically align by inserting leveling bolt through mounting holes in the fan or the base. The isolator must be installed on a level surface.
7. Adjust the isolators by turning the leveling nut counterclockwise several turns at a time alternately on each isolator until the fan weight is transferred onto the isolators and the fan raises uniformly off the blocks. Then remove the blocks.
8. Turn lock nut onto leveling bolt and secure firmly in place against the top of the mounting flange or frame.
9. Secure isolators to mounting surface.

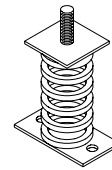

Spring Isolator

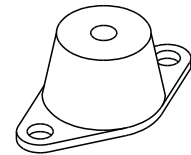

Rubber-in-Shear Isolator

Figure 1 - Floor Mount Isolators

Floor Mounted Rubber-In-Shear (RIS) Isolators

1. Mount fan on isolation base or rails (if supplied).
2. Elevate fan to provide room to insert isolators between the fan and foundation and block in position.
3. Position isolators under fan and secure bolts.
4. Remove blocks and allow fan to rest on floor. Isolators must be installed on a level surface (leveling should not be required).
5. Secure isolators to mounting surface.

Ceiling Mounted Spring and Rubber-in-Shear (RIS) Isolators

1. Elevate fan to operating height and brace.
2. Attach threaded rod to overhead support structure directly above each mounting hole. Rod should extend to within a few feet of fan.
3. Attach isolator to end of threaded rod using a nut on each side of isolator bracket.
4. Insert another section of threaded rod through the fan mounting hole and isolator.
5. Attach two nuts to threaded rod in isolator.
6. Place adjusting nut and locking nut on threaded rod near fan mounting bracket.
7. Alternately rotate adjusting nut at each mounting location until the fan weight is uniformly transferred to the isolators. Remove bracing.

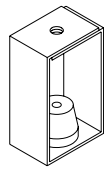
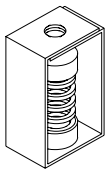

Ceiling Mounted Spring Isolator

Rubber-in-Shear Ceiling Isolator

Figure 2 - Ceiling Mount Isolators

Duct and Damper Installation

Efficient fan performance relies on the proper installation of inlet and discharge ducts as well as dampers. Be sure your fan conforms to the following guidelines and allows three duct diameter of straight duct before placing an elbow or damper. Clearance is also required on the inlet and outlet for maintenance such as pulley or bearing replacement.

Non-Ducted Inlet Clearance

If your fan has an open inlet (no duct work), the fan must be placed one effective wheel diameter away from walls and bulkheads.

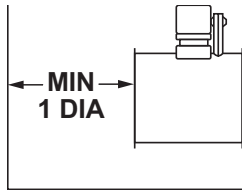

Non-ducted Inlet Clearance

Free Discharge

Avoid a free discharge into the plenum. This will result in lost efficiency because it doesn't allow for a static regain.

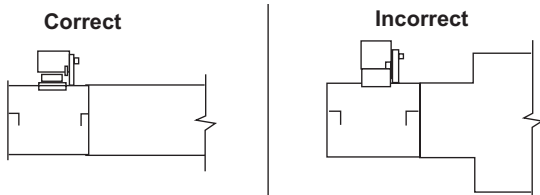

Free Discharge

Inlet Duct Turns

For ducted inlets, allow at least three effective wheel diameters between duct turns or elbows and the fan inlet.

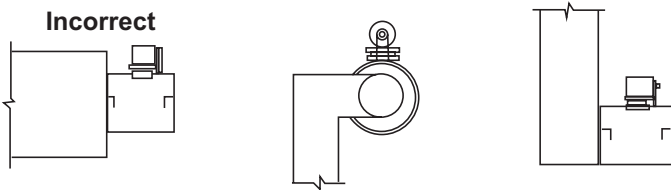
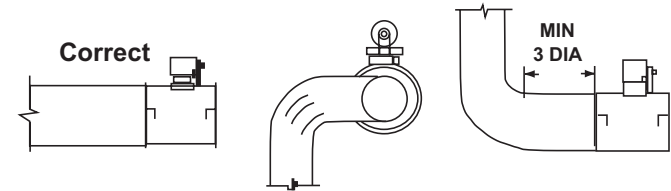

Inlet Duct Turns

Discharge Duct Turns

Where possible, allow three duct diameters between duct turns or elbows and the fan outlet.

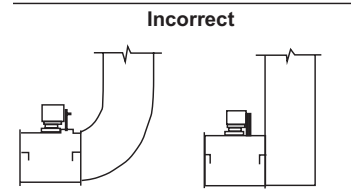
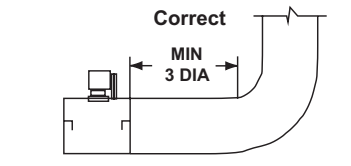

Discharge Duct Turns

Wheel-to-Inlet Clearance

The correct wheel-to-inlet clearance is critical to proper fan performance. This clearance should be verified before initial start-up since rough handling during shipment could cause a shift in fan components. Refer to wheel/inlet drawing below for correct overlap.

Adjust the overlap by loosening the wheel hub and moving the wheel along the shaft to obtain the correct value. Trim balance as necessary following procedure (0.0785 in/sec max).

A uniform radial gap (space between the edge of the cone and the edge of the inlet) is obtained by loosening the inlet cone bolts and repositioning the inlet cone.

Wheel/Inlet Overlap

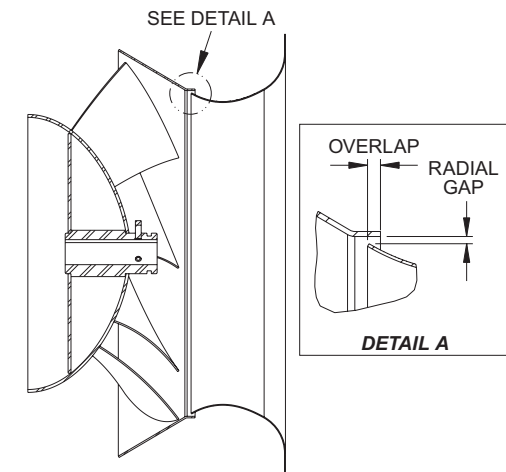

Size	Overlap (inches)
90	5/32
120	3/16
135	3/16
150	7/32
165	7/32
180	7/32
202	1/4
225	9/32
245	5/16
270	5/16
300	3/8
330	13/32
365	7/16
402	1/2
445	17/32
490	19/32
540	21/32
600	3/4

Belt and Pulley Installation

Belt tension is determined by the sound the belts make when the fan is first started. The belts will produce a loud squeal which dissipates after the fan is operating at full capacity. If belt tension is too tight or too loose, lost efficiency and damage can occur.

Do not change the pulley pitch diameter to change tension. This will result in a different fan speed.

1. Loosen motor plate adjustment bolts and move motor plate in order that the belts can easily slip into the grooves on the pulleys. Never pry, roll or force the belts over the rim of the pulley.
2. Adjust the motor plate until proper tension is reached. For proper tension, a deflection of approximately 1/4" per foot

of center distance should be obtained by firmly pressing the belt. Refer to *Figure 3*.

3. Lock the motor plate adjustment nuts in place.
4. Ensure pulleys are properly aligned. Refer to *Figure 4*.

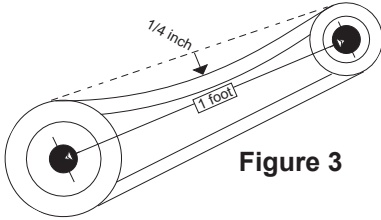

Figure 3

Pulley Alignment

Pulley alignment is adjusted by loosening the motor pulley setscrew and by moving the motor pulley on the motor shaft.

Tolerance

Center Distance	Max. Gap
Up through 12"	1/16"
12" through 48"	1/8"
Over 48"	1/4"

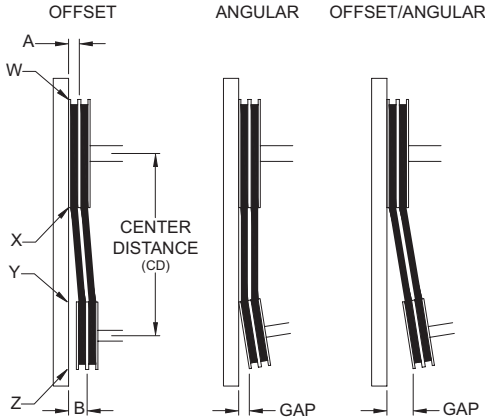

Figure 4

Figure 4 indicates where to measure the allowable gap for the drive alignment tolerance. All contact points (indicated by WXYZ) are to have a gap less than the tolerance shown in the table. When the pulleys are not the same width, the allowable gap must be adjusted by half of the difference in width. *Figure 5* illustrates using a carpenter's square to adjust the position of the motor pulley until the belt is parallel to the longer leg of the square.

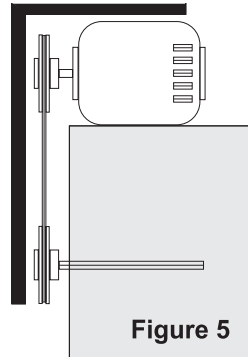

Figure 5

Wiring Installation



NOTICE! Lock off all power sources before unit is wired to power source.

Leave enough slack in the wiring to allow for motor movement when adjusting belt tension. Some fractional motors have to be removed in order to make the connection with the terminal box at the end of the motor. To remove motor, remove bolts securing motor base to power assembly. Do not remove motor mounting bolts.



NOTICE! Follow the wiring diagram in the disconnect switch and the wiring diagram provided with the motor. Correctly label the circuit on the main power box and always identify a closed switch to promote safety (i.e., red tape over a closed switch).

Use of Variable Frequency Drives

Motors

Motors that are to be operated using a Variable Frequency Drive (VFD) must be VFD compatible. At a minimum, this

must be a Premium Efficiency motor with Class F insulation. Motors that are not supplied by Loren Cook Company should have the recommendation of the motor manufacturer for use with a VFD.

Grounding

The fan frame, motor and VFD must be connected to a common earth ground to prevent transient voltages from damaging rotating elements.

Wiring

Line reactors may be required to reduce over-voltage spikes in the motors. The motor manufacturer should be consulted for recommended line impedance and usage of line reactors or filters if the lead length between the VFD and the motor exceeds 10 ft (3m).

Fan

It is the responsibility of the installing body to perform coast-down tests and identify any resonant frequencies after the equipment is fully installed. These resonant frequencies are to be removed from the operating range of the fan by using the "skip frequency" function in the VFD programming. Failure to remove resonant frequencies from the operating range will decrease the operating life of the fan and void the warranty.

Wiring Diagrams

Single Speed, Single Phase Motor

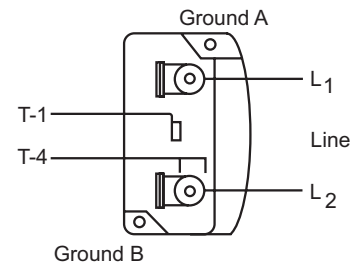

When ground is required, attach to ground A or B with No. 6 thread forming screw. To reverse, interchange T-1 and T-4.

2 Speed, 2 Winding, Single Phase Motor

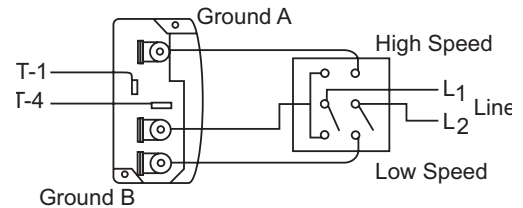

When ground is required, attach to ground A or B with No. 6 thread forming screw. To reverse, interchange T-1 and T-4 leads.

Single Speed, Single Phase, Dual Voltage

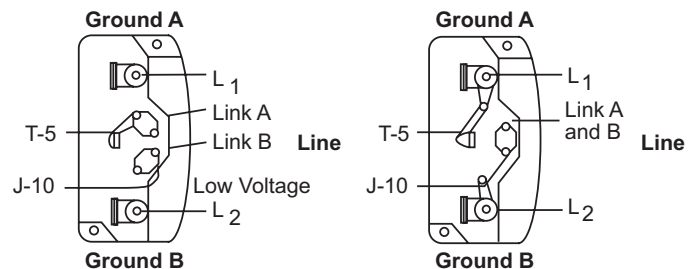

When ground is required, attach to ground A or B with No. 6 thread forming screw. To reverse, interchange T-5 and J-10 leads.

3 Phase, 9 Lead Motor

Y-Connection

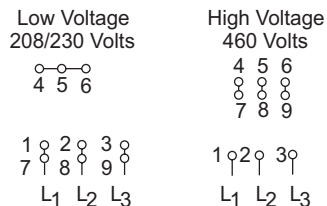

Delta-Connection

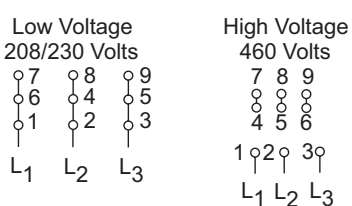

To reverse, interchange any two line leads.

2 Speed, 1 Winding, 3 Phase Motor

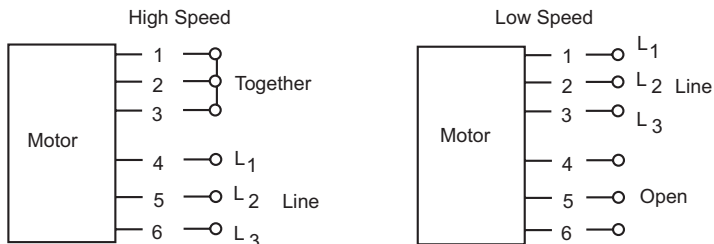

To reverse, interchange any two line leads. Motors require magnetic control.

2 Speed, 2 Winding, 3 Phase

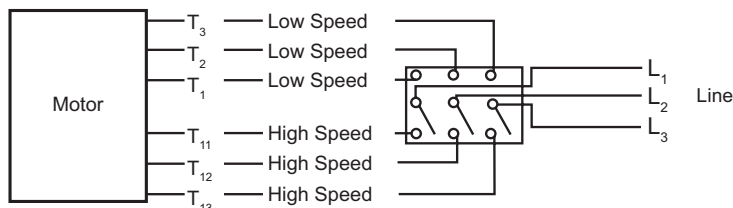

To reverse:

High Speed - interchange leads T₁₁ and T₁₂.

Low Speed - interchange leads T₁ and T₂.

Both Speeds - interchange any two line leads.

Typical Wiring Path for Roof Mounted Units

For sizes 135–600, route conduit under motor cover between the motor support rails and out to enclosure as shown in Figure 1 below.

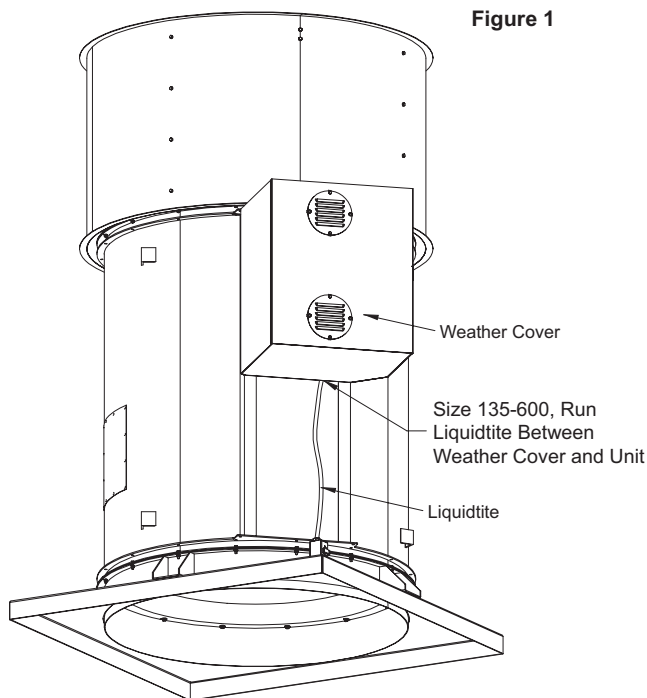
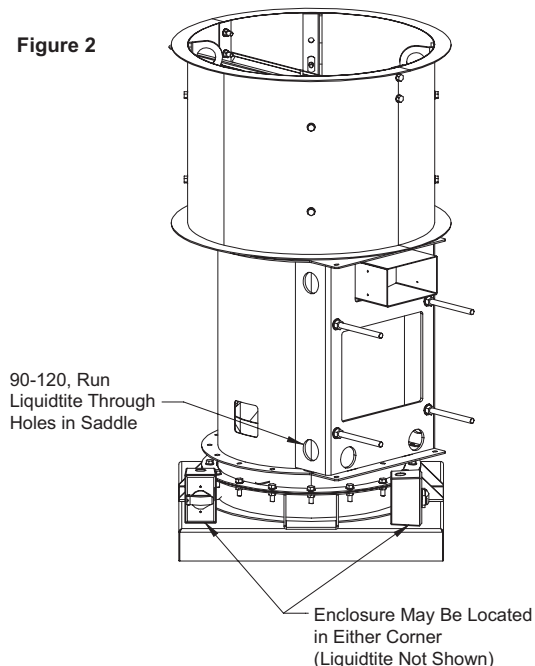

Figure 1

For sizes 90–120, route conduit through holes in the sides of the motor support saddle as shown in Figure 2 below.

Figure 2



Wheel Rotation

Test the fan to ensure the rotation of the wheel is the same as indicated by the arrow marked *Rotation*.

115 and 230 Single Phase Motors

Fan wheel rotation is set correctly at the factory. Changing the rotation of this type of motor should only be attempted by a qualified electrician.

208, 230 and 460 3 Phase Motors

These motors are electrically reversible by switching two of the supply leads. For this reason, the rotation of the fan cannot be restricted to one direction at the factory. See *Wiring Diagrams* for specific information on reversing wheel direction.

NOTICE! Do not allow the fan to run in the wrong direction. This will overheat the motor and cause serious damage. For 3-phase motors, if the fan is running in the wrong direction, check the control switch. It is possible to interchange two leads at this location so that the fan is operating in the correct direction.

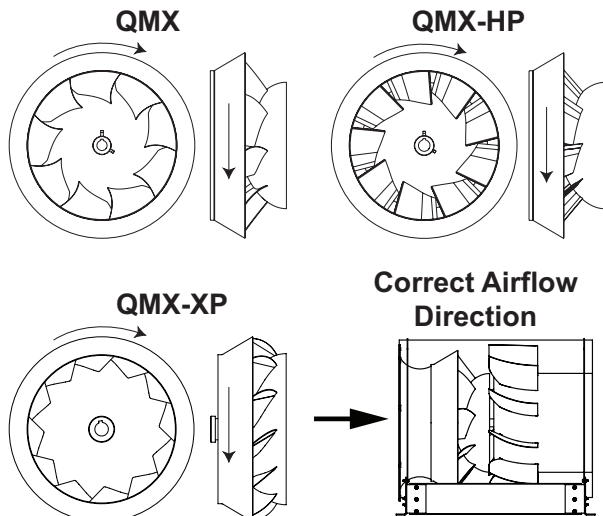

NOTICE! Do not allow the fan airflow to go in the wrong direction.

Final Installation Steps

1. Inspect fasteners and setscrews, particularly fan mounting and bearing fasteners then tighten according to *Recommended Torque for Setscrews/Bolts*.
2. Inspect for correct voltage with a voltmeter.
3. Ensure all accessories are installed.

Operation

Pre-Start Checks

1. Lock out all the primary and secondary power sources.
2. Ensure fasteners and setscrews, particularly those used for mounting the fan, are tightened.
3. Inspect belt tension and pulley alignment.
4. Inspect motor wiring.
5. Ensure belt touches only the pulley.
6. Ensure fan and ductwork are clean and free of debris.
7. Inspect wheel-to-inlet clearance. The correct wheel-to-inlet clearance is critical to proper fan performance.
8. Close and secure all access doors.
9. Restore power to fan.

Start-Up

Turn on the fan. In variable speed units, set fan to its lowest speed and inspect for the following:

- Direction of rotation
- Excessive vibration
- Unusual noise
- Bearing noise
- Improper belt alignment or tension (listen for squealing)
- Improper motor amperage or voltage



NOTICE! If a problem is discovered, immediately shut off the fan. Lock out all electrical power and check for the cause of the trouble. Refer to *Troubleshooting*.

Inspection

Inspection of the fan should be conducted at the first **30 minute**, **8 hour** and **24 hour** intervals of satisfactory operation. During the inspections, stop the fan and inspect as per the *Conditions Chart*.

30 Minute Interval

Inspect bolts, setscrews and motor mounting bolts. Adjust and tighten as necessary.

8 Hour Interval

Inspect belt alignment and tension. Adjust and tighten as necessary.

24 Hour Interval

Inspect belt tension. Adjust and tighten as necessary.

Recommended Torque for Setscrews/Bolts (IN-LB)

Size	Key Hex Across Flats	Setscrews		Hold Down Bolts	
		Recommended Torque Min.	Recommended Torque Max.	Size	Recommended Torque
#8	5/64"	15	21	3/8"-16	324
#10	3/32"	27	33	1/2"-13	780
1/4	1/8"	70	80	5/8"-11	1440
5/16	5/32"	140	160	3/4"-10	2400
3/8	3/16"	250	290	7/8"-9	1920
7/16	7/32"	355	405	1"-8	2700
1/2	1/4"	560	640	1-1/8"-7	4200
5/8	5/16"	1120	1280	1-1/4"-7	6000
3/4	3/8"	1680	1920	-	-
7/8	1/2"	4200	4800	-	-
1	9/16"	5600	6400	-	-

Maintenance

Establish a schedule for inspecting all parts of the fan. The frequency of inspection depends on the operating conditions and location of the fan.

Inspect fans exhausting corrosive or contaminated air within the first month of operation. Fans exhausting contaminated air (airborne abrasives) should be inspected every three months.

Regular inspections are recommended for fans exhausting non-contaminated air.

It is recommended the following inspections be conducted twice per year:

- Inspect bolts and setscrews for tightness. Tighten as necessary
- Inspect belt wear and alignment. Replace worn belts with new belts and adjust alignment as needed. Refer to *Belt and Pulley Installation*, page 3
- Bearings should be inspected as recommended in the *Conditions Chart*
- Inspect variable inlet vanes (if supplied) for freedom of operation and excessive wear. The vane position should agree with the position of the control arm. As the variable inlet vanes close, the entering air should spin in the same direction as the wheel
- Inspect springs and rubber isolators for deterioration and replace as needed
- Inspect for cleanliness. Clean exterior surfaces only. Removing dust and grease on motor housing assures proper motor cooling. Removing dirt from the wheel and housing prevents imbalance and damage

Lubrication

Fan Bearings



NOTICE! The fan bearings are provided prelubricated. Any specialized lubrication instructions on fan labels supersedes information provided herein. Bearing grease is a petroleum lubricant in a lithium base conforming to an NLGI #2 consistency. If user desires to utilize another type of lubricant, they take responsibility for flushing bearings and lines, and maintaining a lubricant that is compatible with the installation.

QMX bearings are lubricated through a grease fitting on the exterior of the fan housing and should be lubricated by the schedule, *Conditions Chart*.

For best results, lubricate the bearing while the fan is in operation. Pump grease in slowly until a slight bead forms around the bearing seals. Excessive grease can burst seals thus reducing bearing life.

Lubrication Conditions Chart

Fan Class	Fan Status	Shaft Size	Maximum Interval (operation hrs)
QMX	Normal Conditions (clean, dry & smooth)	>1-1/2"	7500
		<1-1/2"	2000
	Extreme Conditions (dirty/wet/rough)	>1-1/2"	1500
		<1-1/2"	400
QMXHP	Normal Conditions (clean, dry & smooth)	>2"	5000
		<2"	1000
	Extreme Conditions (dirty/wet/rough)	>2"	1000
		<2"	200
QMXXP	Normal Conditions (clean, dry & smooth)	>4"	2000
		<4"	1000
	Extreme Conditions (dirty/wet/rough)	>4"	400
		<4"	200

In the event the bearing cannot be seen, use no more than three injections with a hand-operated grease gun.

Before lubricating, the grease nipple and immediate vicinity should be thoroughly cleaned without the use of high pressure equipment. The grease should be supplied slowly as the bearing rotates until fresh grease slips past the seal. Excessive pressure should be avoided to prevent seal damage.

Exceptions to the greasing interval chart:

- **Periodic Applications (any break of one week or more):** It is recommended that full lubrication be performed prior to each break in operation
- **Higher Temperature:** It is recommended to halve the intervals for every 30°F increase in operating temperature above 120°F not to exceed 230°F for standard bearings; high temperature bearings (optional) can operate up to 400°F
- **Vertical Shaft:** It is recommended that the intervals should be halved

Motor Bearings

Motors are provided with prelubricated bearings. Any lubrication instructions shown on the motor nameplate supersede instructions below.

Motor bearings without provisions for relubrication will operate up to 10 years under normal conditions with no maintenance. In severe applications, high temperatures or excessive contaminants, it is advisable to have the maintenance department disassemble and lubricate the bearings after three years of operation to prevent interruption of service.

For motors with provisions for relubrication, follow intervals of the table below.

Relubrication Intervals

Service Conditions	NEMA Frame Size					
	Up to and Including 184T		213T-365T		404T and Larger	
	1800 RPM and Less	Over 1800 RPM	1800 RPM and Less	Over 1800 RPM	1800 RPM and Less	Over 1800 RPM
Standard	3 yrs.	6 months	2 yrs.	6 months	1 yr.	3 months
Severe	1 yr.	3 months	1 yr.	3 months	6 months	1 month

Motors are provided with a polyurea mineral oil NGLI #2 grease. All additions to the motor bearings are to be with a compatible grease such as Exxon Mobil Polyrex EM and Chevron SRI.

The above intervals should be reduced to half for vertical shaft installations.

Motor Services

Should the motor prove defective within a one-year period, contact your local Loren Cook representative or your nearest authorized electric motor service representative.

Changing Shaft Speed

All belt driven fans with motors up to and including 5HP are equipped with variable pitch pulleys. To change the fan speed, perform the following:

1. Loosen setscrew on driver (motor) pulley and remove key, if equipped.
2. Turn the pulley rim to open or close the groove facing. If the pulley has multiple grooves, all must be adjusted to the same width.
3. After adjustment, inspect for proper belt tension.

Maximum RPM

Size	QMX		QMXHP		QMXXP	
	Level 1	Level 2	Level 1	Level 2	Level 2	Level 3
90	-	4000	-	4000	-	-
120	-	3707	-	4000	-	-
135	-	3295	-	3876	-	-
150	-	2907	-	3510	2920	3940
165	1975	2633	2368	3191	2654	3582
180	1811	2420	2171	2884	2433	3231
202	1610	2152	1935	2600	2168	2919
225	1449	1937	1737	2340	1947	2626
245	1330	1774	1595	2097	1767	2361
270	1166	1623	1386	1819	1603	2134
300	1000	1465	1248	1679	1426	1921
330	856	1332	1134	1527	1296	1791
365	801	1204	1026	1381	1172	1604
402	709	1080	931	1252	1064	1458
445	612	988	841	1132	961	1312
490	602	897	759	1028	871	1202
540	523	813	693	912	792	1069
600	459	732	624	840	703	959

Speed Reduction

Open the pulley in order that the belt rides deeper in the groove (smaller pitch diameter).

Speed Increase

Close the pulley in order that the belt rides higher in the groove (larger pitch diameter). Ensure that the RPM limits of the fan and the horsepower limits of the motor are maintained.

Pulley and Belt Replacement

1. Loosen and remove belts by adjusting motor mounting plate.
2. Remove pulleys from their respective shafts.
3. Clean the motor and fan shafts.
4. Clean bores of pulleys and coat bores with heavy oil.
5. Remove grease, rust or burrs from pulleys and shafts.
6. Remove burrs from shaft by sanding.

7. Place fan pulley on fan shaft and motor pulley on motor shaft. Damage to pulleys can occur when excessive force is used in placing the pulleys on their respective shafts.
8. Tighten in place.
9. Install belts on pulleys and align as described in *Belt and Pulley Installation*, page 3.

Bearing Replacement

The fan bearings are pillow block ball bearings.

1. Loosen and remove belts by adjusting motor mounting plate.
2. Remove the bearing cover by removing the bolts around the perimeter of the bearing cover. **Do not remove fan sheave yet.**
3. Remove inlet cone by removing attaching bolts/nuts around perimeter of the inlet plate.
4. Remove wheel by loosening setscrews and sliding off shaft.
5. Record the location of the fan sheave from end of shaft, and remove the sheave.
6. Record the distance from the bearing to the end of the shaft.
7. Loosen setscrews on bearings and remove shaft.
8. Remove bearings from bearing base and replace with new ones, noting the exact location of each; **do not fully tighten base bolts.**
9. Slide shaft through bearings until shaft protrudes the same amount as measured above. Tapping the inner race

- of each bearing with a soft driver may be required. **Do not hammer the end of the shaft or the bearing housing.**
10. Return setscrews to the same location as marked above and tighten one setscrew on each bearing to half its specified torque.
11. Rotate shaft to allow bearings to align themselves.
12. Replace wheel but do not tighten yet.
13. Replace inlet cone. Wheel may need to be moved to allow proper alignment. Care should be taken to insure that inlet cone is centered inside wheel before and after tightening attaching bolts.
14. Slide wheel on shaft to achieve proper wheel/inlet overlap and tighten wheel set screws. Refer to *Wheel-to-Inlet Clearance*, page 3.
15. Tighten hold-down bolts to proper torque.
16. Turn the shaft by hand. Resistance should be the same as it was before hold-down bolts were fully tightened.
17. Tighten all bearing setscrews to full specified torque.
18. Replace the sheave, align with motor sheave and adjust the belt tension.
19. Test run fan and retighten all setscrews and bolts and trim balance as necessary. (0.0785 in/sec max).
20. Replace discharge cover.

Wheel Replacement (Belt Drive)

The wheel has a pre-machined shoulder in the hub for the use of most two and three jaw mechanical pullers.

1. Align center of the puller with the center of the shaft.
2. Ensure all setscrews in the hub, normally two, are fully removed.
3. Slowly remove wheel from the shaft.

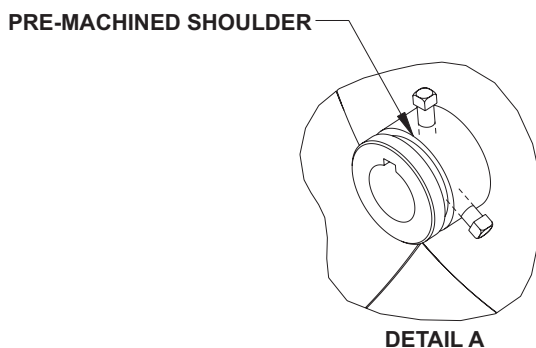
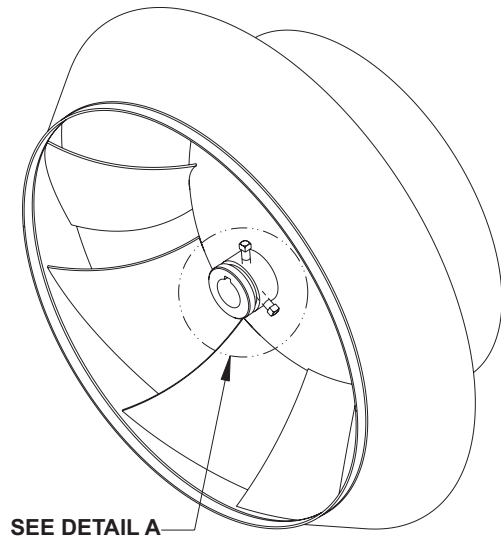

Troubleshooting

Problem and Potential Cause

Low Capacity or Pressure:

- Incorrect direction of rotation. Make sure the fan rotates in same direction as the arrows on the motor or belt drive assembly
- Poor fan inlet conditions. There should be a straight clear duct at the inlet or outlet
- Improper wheel alignment
- Fan backwards. Refer to airflow diagram on page 5

Excessive Vibration and Noise:

- Damaged wheel
- Belts misaligned
- Belts too loose; worn or oily belts
- Loose fasteners
- Speed too high
- Incorrect direction of rotation. Make sure the fan rotates in same direction as the arrows on the motor or belt drive assembly
- Bearing setscrews loose
- Bearings need lubrication or replacement
- Debris in impeller
- Fan surge
- See page 4 for issues regarding use of VFD

Overheated Motor:

- Motor improperly wired
- Incorrect direction of rotation. Make sure the fan rotates in same direction as the arrows on the motor or belt drive assembly
- Cooling air diverted or blocked
- Improper inlet clearance
- Incorrect fan speed
- Incorrect voltage

Overheated Bearings:

- Improper bearing lubrication
- Excessive belt tension

Parts List

QMX/QMXDHP/QMXHP/QMXD/QMXXP

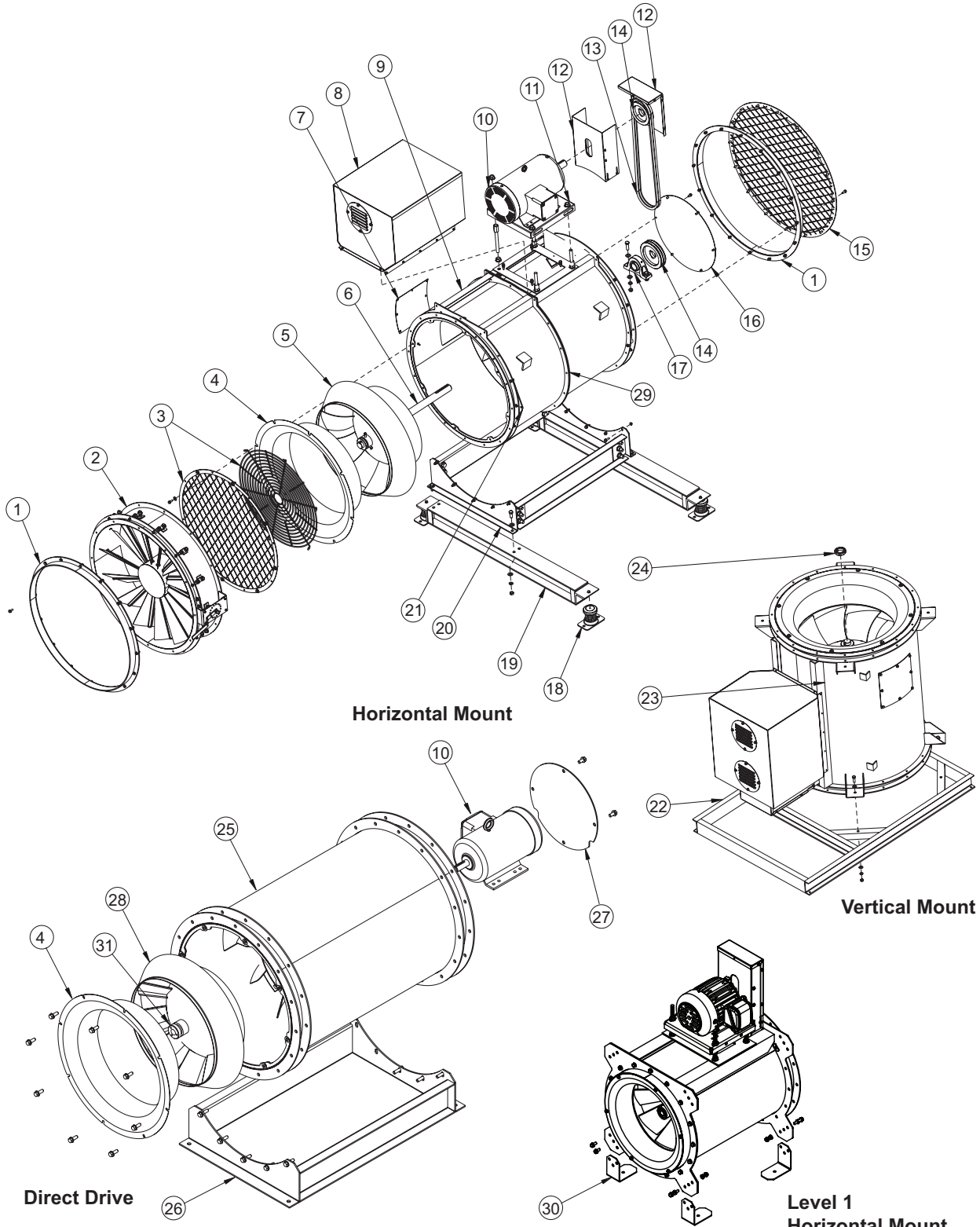

Horizontal Mount

Vertical Mount

Direct Drive

**Level 1
Horizontal Mount**

Part No.	Description	Part No.	Description	Part No.	Description
1	Companion Flange (optional)	16	Bearing Cover	31	Taper Lock Bushing
2	External Inlet Vane Damper (optional)	17	Bearings (two required)		
3	Inlet Spiral Guard or Safety Screen (optional)	18	Isolator (four required optional)		
4	Inlet Cone	19	Isolation Rails - Horizontal Mount (optional)		
5	Mixed Flow Wheel	20	Base - Horizontal Mount (QMX)		
6	Shaft	21	Thrust Restraint - Horizontal Mount (optional)		
7	Access Door (optional)	22	Isolation Structure - Vertical Mount (optional)		
8	Motor Cover (optional)	23	Housing - Vertical Mount (QMX)		
9	Housing-Horizontal Mount (QMX)	24	Shaft Locking Collar - Vertical Mount		
10	Motor	25	Housing - Direct Drive		
11	Motor Plate (QMX)	26	Base - Direct Drive		
12	Belt Guard	27	Motor Cover - Direct Drive		
13	Belt Set	28	Mix-Flow Wheel - Direct Drive		
14	Sheaves	29	Horizontal Split Housing (optional)		
15	Discharge Safety Screen (optional)	30	Mounting Feet - Level 1 Horizontal Mount		

QMXE/QMXHPE

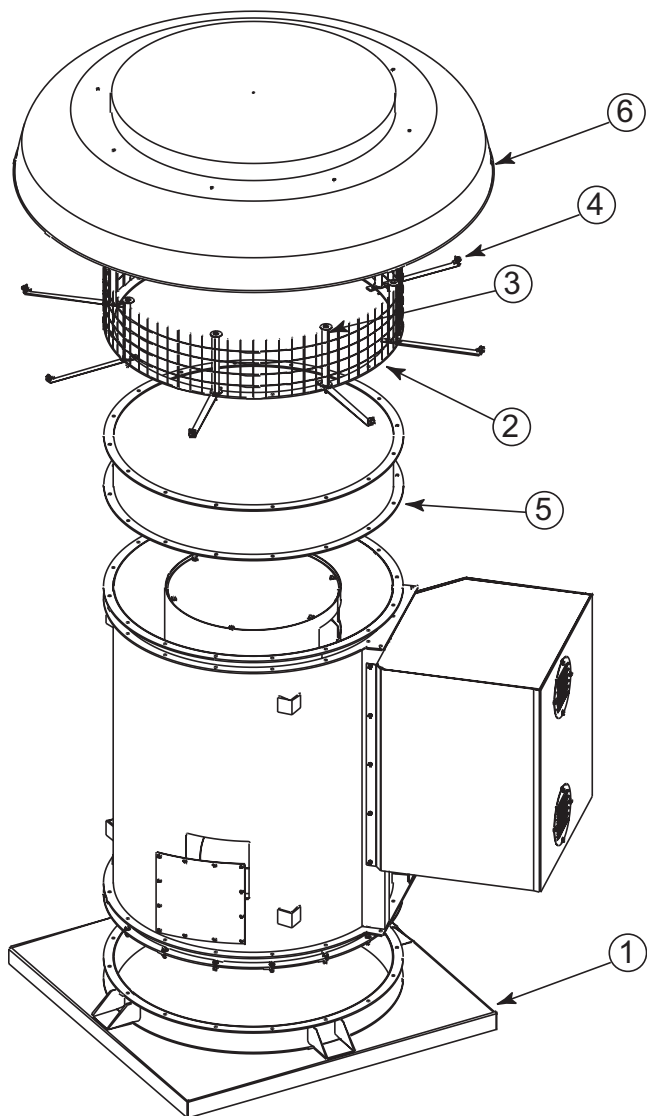

Part No.	Description
1	QMX Curb Cap
2	QMXE Birdscreen
3	QMXE Top Cap Post
4	QMXE Baffle Brace
5	QMXE Top Cap Extension (for size 90 only)
6	QMXE Top Cap

See common parts (not shown) listed on page 9.

QMXS/QMXHPS

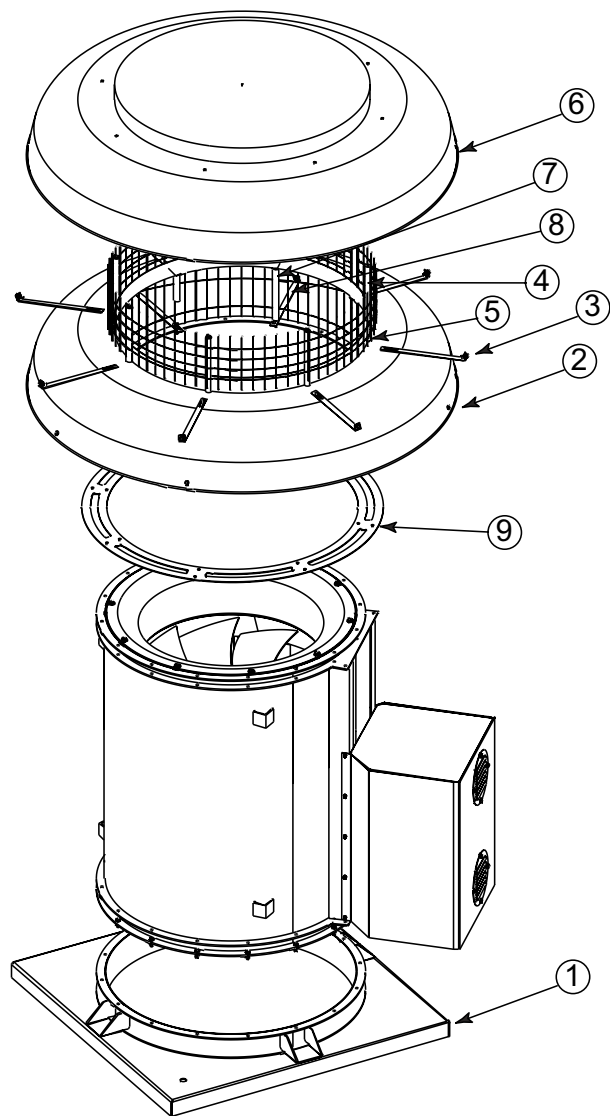

Part No.	Description
1	QMX Curb Cap
2	QMXS Top Cap - Open
3	QMXS Upper Baffle Brace
4	QMXS Top Cap Post
5	QMXS Birdscreen
6	QMXS Top Cap
7	QMXS Lower Top Cap Post
8	QMXS Lower Baffle Brace
9	QMXS Adapter Plate

See common parts (not shown) listed on page 9.

QMXU/QMXHPU

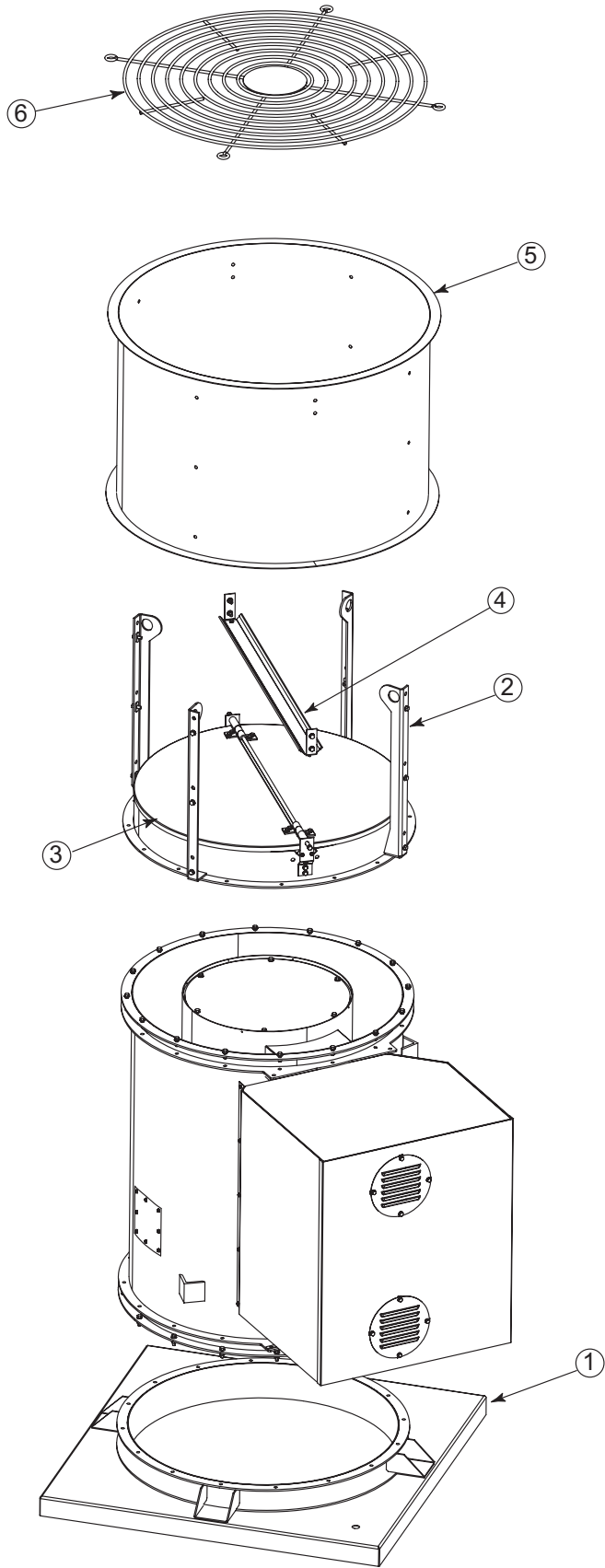

Part No.	Description
1	QMX Curb Cap
2	QMXU Lifting Lug
3	QMXU Damper
4	QMXU Damper Stop
5	QMXU Windband
6	QMXU Discharge Guard (optional)

See common parts (not shown) listed on page 9.

QMXLE/QMXHPLE

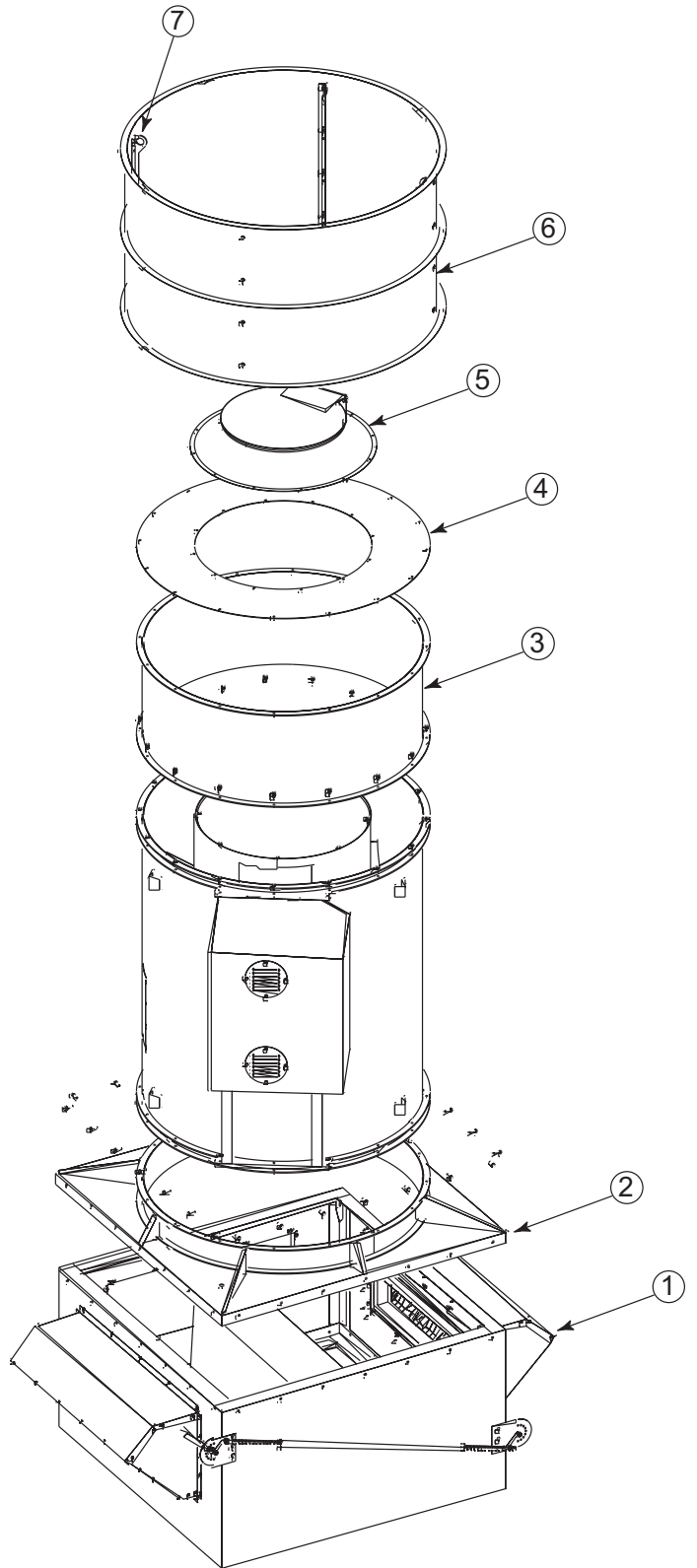

Part No.	Description
1	QMXLE Mixing Box
2	QMXLE Curb Cap
3	QMXLE Middle Section
4	QMXLE Adapter Plate
5	QMXLE Stack Damper
6	QMXLE Windband
7	QMXLE Lifting Lug

See common parts (not shown) listed on page 9.

Arrangement 3

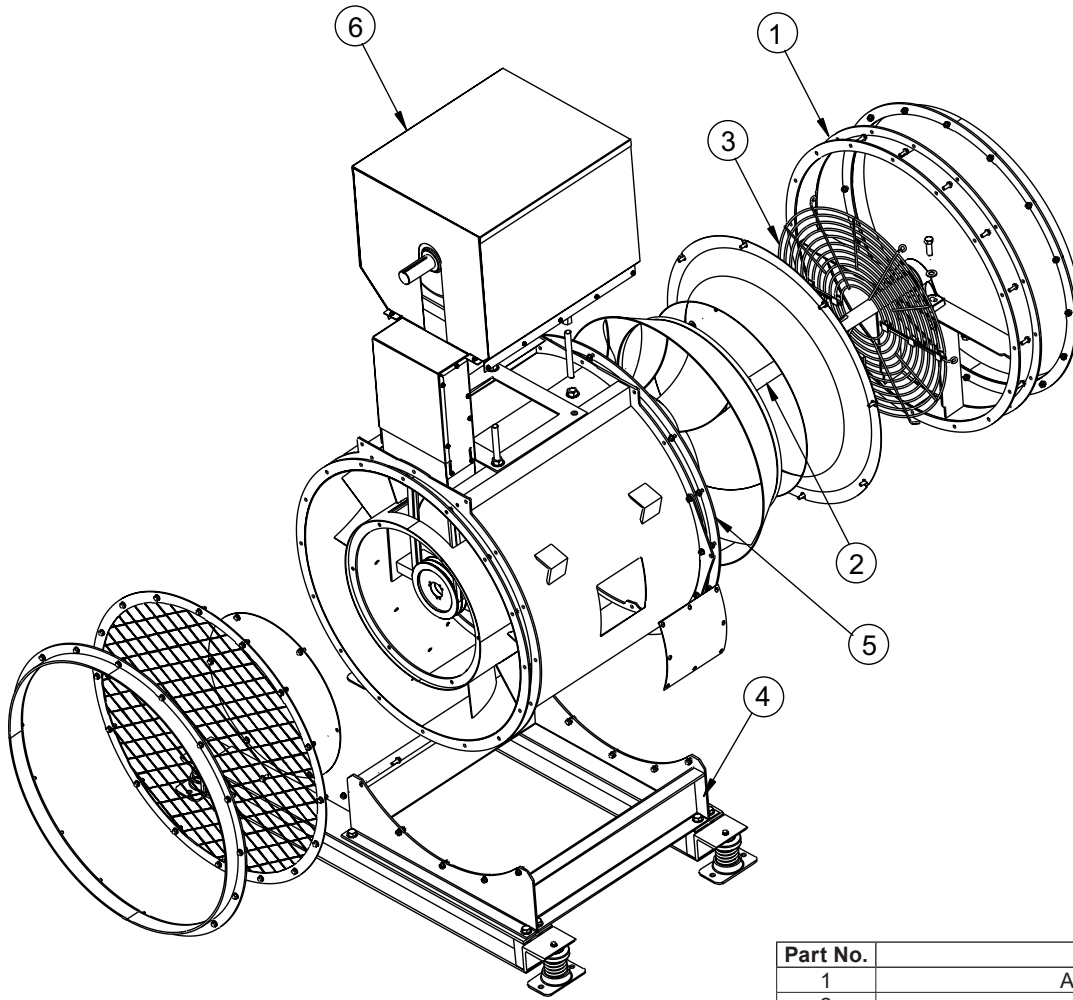

Part No.	Description
1	Arr. 3 Bearing Support
2	Arr. 3 Shaft
3	Arr. 3 Spiral Guard
4	Arr. 3 Base
5	Arr. 3 Housing
6	Arr. 3 Motor Cover

See common parts (not shown) listed on page 9.

Limited Warranty

Loren Cook Company warrants that your Loren Cook fan was manufactured free of defects in materials and workmanship, to the extent stated herein. For a period of one (1) year after date of shipment, we will replace any parts found to be defective without charge, except for shipping costs which will be paid by you. This warranty is granted only to the original purchaser placing the fan in service. This warranty is void if the fan or any part thereof has been altered or modified from its original design or has been abused, misused, damaged or is in worn condition or if the fan has been used other than for the uses described in the company manual. This warranty does not cover defects resulting from normal wear and tear. To make a warranty claim, notify Loren Cook Company, General Offices, 2015 East Dale Street, Springfield, Missouri 65803-4637, explaining in writing, in detail, your complaint and referring to the specific model and serial numbers of your fan. Upon receipt by Loren Cook Company of your written complaint, you will be notified, within thirty (30) days of our receipt of your complaint, in writing, as to the manner in which your claim will be handled. If you are entitled to warranty relief, a warranty adjustment will be completed within sixty (60) business days of the receipt of your written complaint by Loren Cook Company. This warranty gives only the original purchaser placing the fan in service specifically the right. You may have other legal rights which vary from state to state. For fans provided with motors, the motor manufacturer warrants motors for a designated period stated in the manufacturer's warranty. Warranty periods vary from manufacturer to manufacturer. Should motors furnished by Loren Cook Company prove defective during the designated period, they should be returned to the nearest authorized motor service station. Loren Cook Company will not be responsible for any removal or installation costs.



LOREN COOK COMPANY

Corporate Offices: 2015 E. Dale St. Springfield, MO 65803
 Phone 417-869-6474 | Fax 417-862-3820 | lorencook.com