



COOK

Restrained Spring Floor

DATE: _____

PROJECT: _____

LOCATION: _____

**Restrained Spring
Isolator
Floor Mounted
2" Deflection**

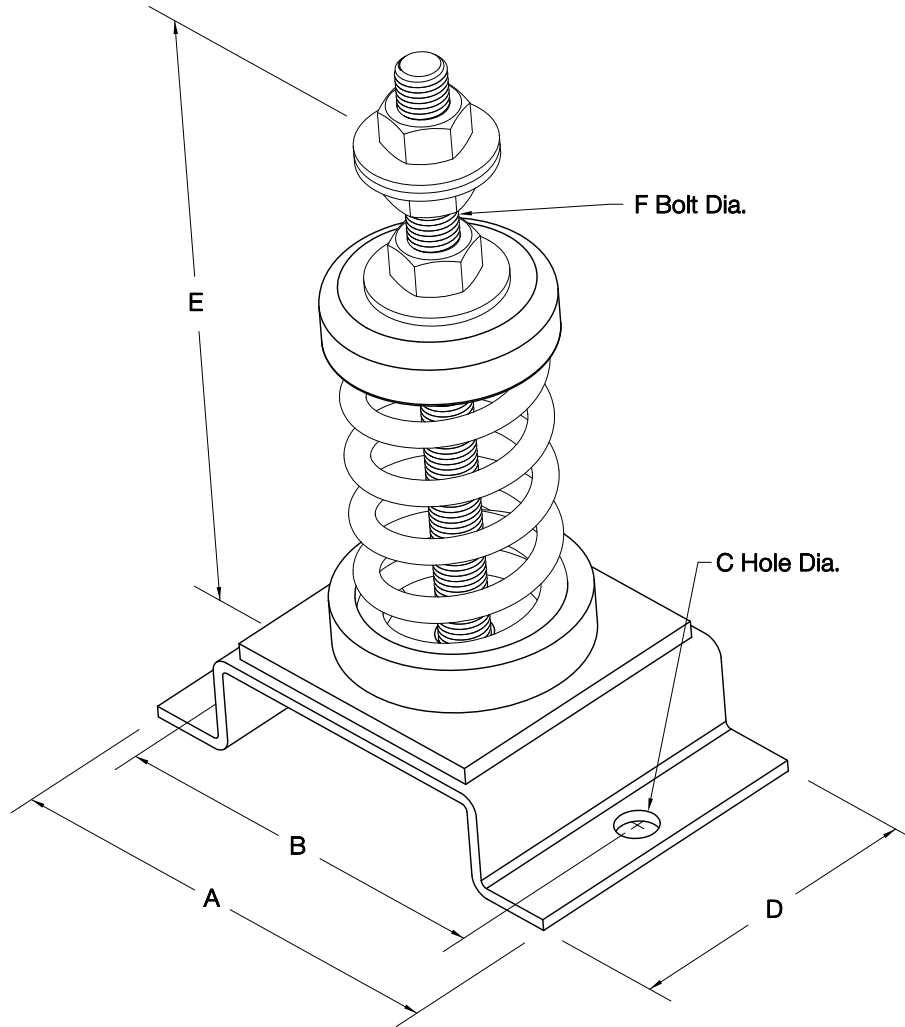

DIMENSION DATA

L.C. Model	Manuf	Manuf Model	Rated Load	Rated Deflection	Spr.Rate (lbs/in)	A Length	B Centerline	C Hole Dia.	D Base W.	E Op. Ht.	F Bolt	Ship Wt.
RS2-100	KNC	FRS-2-100	100	2	50	8	6-1/2	11/16	4-1/2	11	5/8	8
RS2-135	KNC	FRS-2-135	135	2	68	8	6-1/2	11/16	4-1/2	11	5/8	8
RS2-225	KNC	FRS-2-225	225	2	113	8	6-1/2	11/16	4-1/2	11	5/8	8
RS2-375	KNC	FRS-2-375	375	2	188	8	6-1/2	11/16	4-1/2	11	5/8	8
RS2-625	KNC	FRS-2-625	625	2	313	8	6-1/2	11/16	4-1/2	11	5/8	8
RS2-1400	KNC	FRS-2-1400	1400	2.01	697	8	6-1/2	11/16	4-1/2	11	5/8	11
RS2-1600	KNC	FRS-2-1600	1600	2	800	8	6-1/2	11/16	4-1/2	11	5/8	11
RS2-1975	KNC	FRS-2-1975	1975	1.98	998	8	6-1/2	11/16	4-1/2	11	5/8	12

ALL DIMENSIONS IN INCHES.
ALL ISOLATORS LISTED ARE DESIGNED TO PROVIDE A MINIMUM OF 50% OVERLOAD CAPACITY,