



**COOK**

**CPS-CPA**

DATE: \_\_\_\_\_  
 PROJECT: \_\_\_\_\_  
 LOCATION: \_\_\_\_\_



**Flat Blade Centrifugal Blower  
 Clockwise Top Angular Down  
 Arrangement 10, Class I**

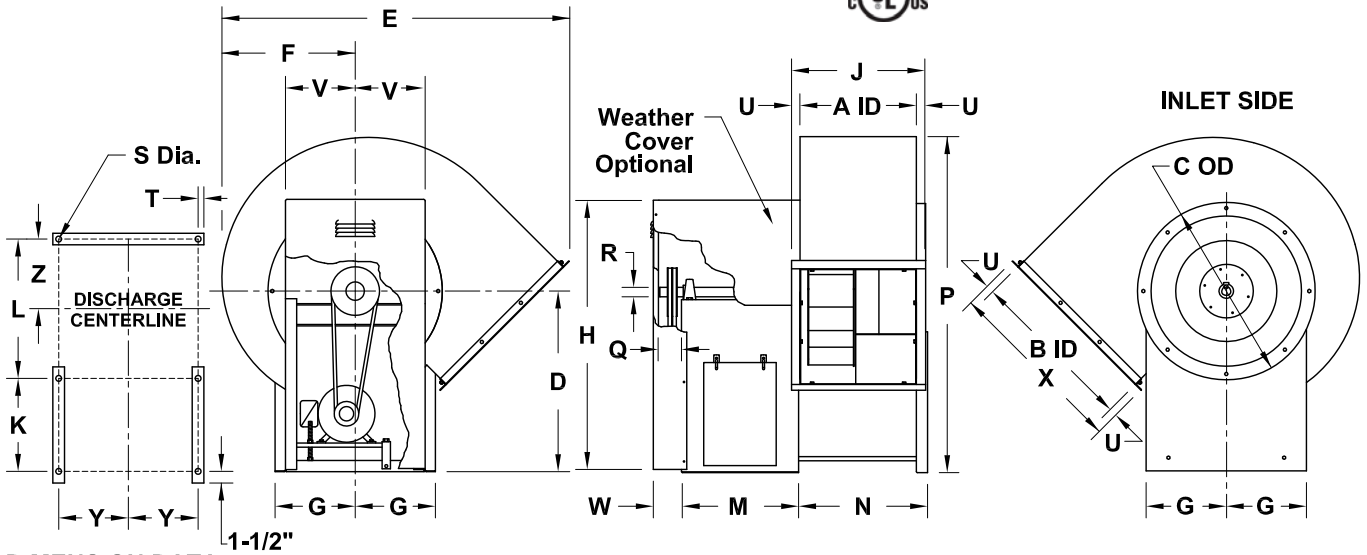

**DIMENSION DATA**

Size	A	B	C	D	E	F	G	H*	J	K	L	M
60	7-9/16	10-15/16	14-1/8	18	26-11/16	8-7/8	9-3/8	25-1/4	10-3/4	10	10-1/4	13-1/8
70	7-9/16	10-15/16	14-1/8	18	26-11/16	8-7/8	9-3/8	25-1/4	10-3/4	10	10-1/4	13-1/8
80	7-9/16	10-15/16	14-1/8	18	26-11/16	8-7/8	9-3/8	25-1/4	10-3/4	10	10-1/4	13-1/8
100	7-9/16	10-15/16	14-1/8	18	26-11/16	8-7/8	9-3/8	25-1/4	10-3/4	10	10-1/4	13-1/8
120	9-3/16	13-1/8	16-1/8	18	30-1/2	10-11/16	9-3/8	26-1/4	12-3/8	10	11-7/8	13-1/8
135	10-5/16	14-3/4	17-5/8	18	33-5/16	12	9-3/8	27	13-1/2	12	13	15-1/8
150	11-7/16	16-7/16	19-1/8	19-1/16	36-13/16	13-5/16	9-3/8	29-1/16	14-5/8	12	14-1/8	15-1/8
165	12-5/8	18-1/16	21-3/16	20-7/16	40	14-5/8	9-3/8	31-7/16	15-13/16	12	15-5/16	15-1/8
180	13-3/4	19-11/16	22-11/16	22-1/16	43-3/8	15-15/16	10-3/8	33-9/16	16-15/16	12	16-7/16	15-1/8
195	14-15/16	21-5/16	24-3/16	23-11/16	45-15/16	17-1/4	10-3/8	35-11/16	18-3/16	15	17-5/8	18-1/8
210	16-1/16	23	25-15/16	25-3/8	50-1/16	18-5/8	11-3/8	38-7/8	19-5/16	15	18-3/4	18-1/8
225	17-3/16	24-5/8	27-7/16	27	52-15/16	19-15/16	11-7/8	41	20-7/16	15	19-7/8	18-1/8
245	18-3/4	26-13/16	29-7/16	29-5/8	57-3/8	21-11/16	13-3/8	44-5/8	23	15	21-11/16	18-1/8
270	20-5/8	29-9/16	31-15/16	32-3/8	62-11/16	23-15/16	14-3/8	48-7/8	24-7/8	18	23-9/16	21-1/8
300	22-15/16	32-13/16	34-15/16	35-5/8	69-7/16	26-9/16	15-5/16	53-5/8	27-3/16	18	26	21-3/16
330	25-1/4	36-1/8	37-15/16	38-7/8	76-1/4	29-1/4	16-13/16	58-3/8	29-7/16	18	28-5/16	21-3/16
365	27-7/8	39-15/16	41-7/16	42-3/4	83-15/16	32-3/16	17-13/16	64-1/4	32-1/16	21	30-15/16	24-3/16
402	30-3/4	44-1/16	45-3/16	46-3/4	92-5/8	35-5/8	19-13/16	70-1/4	34-15/16	21	34-5/16	24-3/16
445	34	48-11/16	49-7/16	51-3/8	102-3/16	39-3/8	21-13/16	76-7/8	38-3/16	25	37-9/16	28-3/16
490	37-7/16	53-5/8	55	56-1/4	112-5/16	43-5/16	23-13/16	84-1/4	41-5/8	25	41	28-3/16

Size	N	P*	Q	R	S	T	U*	V*	W	X	Y	Z	Max Mtr Frame	Ship Wt. CPS/CPA
60	9-3/8	28-1/4	3	1	9/16	3/4	1-5/8	8	4	14-1/16	8-5/8	4-5/8	145T	173 118
70	9-3/8	28-1/4	3	1	9/16	3/4	1-5/8	8	4	14-1/16	8-5/8	4-5/8	145T	173 118
80	9-3/8	28-1/4	3	1	9/16	3/4	1-5/8	8	4	14-1/16	8-5/8	4-5/8	145T	173 118
100	9-3/8	28-1/4	3	1	9/16	3/4	1-5/8	8	4	14-1/16	8-5/8	4-5/8	145T	173 118
120	11	30-5/16	3	1	9/16	3/4	1-5/8	8	4	16-5/16	8-5/8	5-7/16	184T	221 153
135	12-1/8	31-13/16	3	1	9/16	3/4	1-5/8	8	4	17-15/16	8-5/8	6	184T	255 180
150	13-1/4	34-7/16	3	1	9/16	3/4	1-5/8	8	4	19-5/8	8-5/8	6-9/16	184T	291 208
165	14-7/16	37-5/16	3	1	9/16	3/4	1-5/8	8	4	21-1/4	8-5/8	7-3/16	184T	334 237
180	15-9/16	40-7/16	3	1-3/16	9/16	3/4	1-5/8	9	4	22-7/8	9-5/8	7-3/4	215T	396 266
195	16-3/4	43-9/16	3	1-3/16	9/16	3/4	1-5/8	9	4	24-1/2	9-5/8	8-5/16	215T	440 297
210	17-7/8	46-13/16	4	1-7/16	9/16	3/4	1-5/8	10	5	26-3/16	10-5/8	8-7/8	215T	490 329
225	19	50	4	1-7/16	9/16	3/4	1-5/8	10-1/2	5	27-13/16	11-1/8	9-7/16	215T	537 361
245	21-1/16	54-5/8	4	1-11/16	11/16	1	2-1/8	11-1/2	5	31	12-3/8	10-5/8	215T	608 406
270	22-15/16	59-15/16	4	1-11/16	11/16	1	2-1/8	12-1/2	5	33-3/4	13-3/8	11-7/16	256T	722 463
300	25-5/16	66-1/4	4	1-15/16	11/16	1	2-1/8	13-1/2	5	37	14-5/16	12-5/8	256T	879 535
330	27-5/8	72-5/8	4	1-15/16	13/16	1	2-1/8	15	5	40-5/16	15-13/16	13-3/4	256T	1035 604
365	30-1/4	80	5	2-3/16	13/16	1	2-1/8	16	6	44-3/16	16-13/16	15-1/16	324T	1230 699
402	34-1/8	87-13/16	5	2-3/16	13/16	1	2-1/8	18	6	48-5/16	18-13/16	17	324T	1519 797
445	37-3/8	96-13/16	5	2-7/16	13/16	1	2-1/8	20	6	52-15/16	20-13/16	18-5/8	326T	1938 915
490	40-13/16	106-3/16	5	2-7/16	13/16	1	2-1/8	22	6	57-7/8	22-13/16	20-3/8	326T	2319 1044

ALL DIMENSIONS IN INCHES. WEIGHTS IN LBS., LESS MOTOR. \* REFERENCE DIMENSION.

VS211R07