

DATE: _____
 PROJECT: _____
 LOCATION: _____

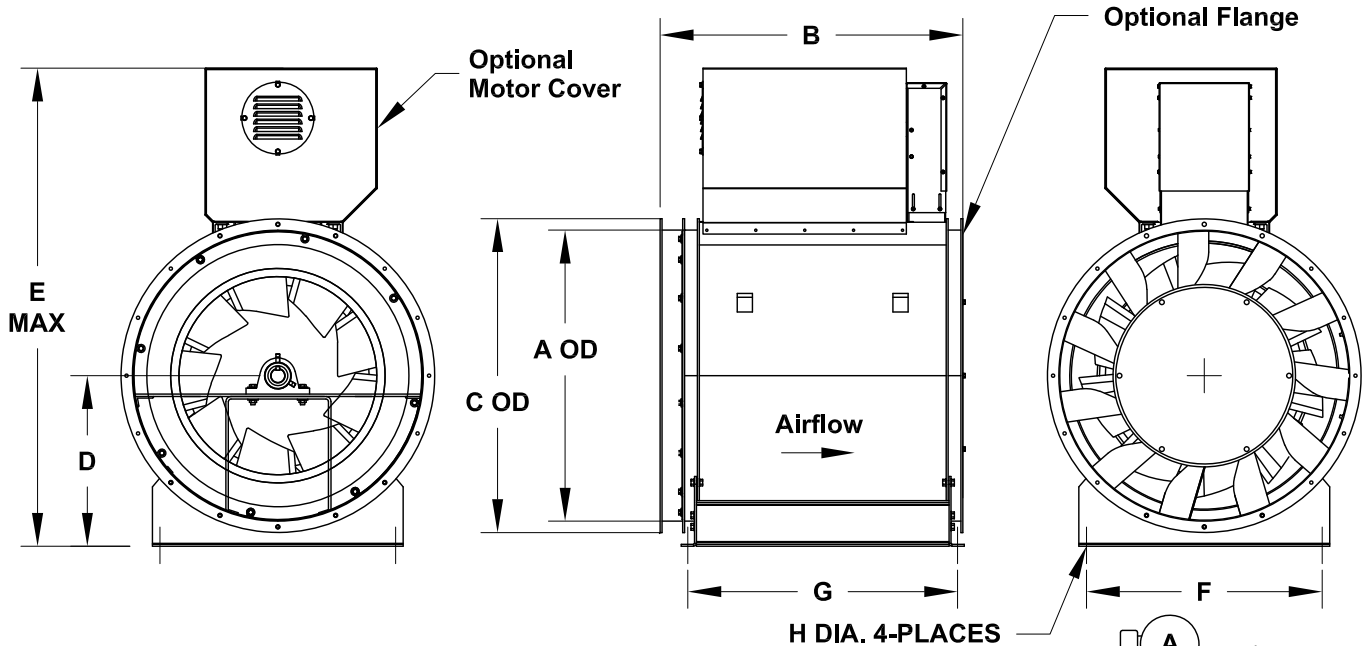

**Mixed Flow Inline
 Horizontal Mount
 Level 2, Belt Drive
 Arrangement 3**



STANDARD CONSTRUCTION FEATURES:

High efficiency mixed flow wheel - Continuously welded steel housing with Lorenized powder coating - Welded areodynamic straightening vanes - Integral outlet collar for slip fit duct connection - Adjustable motor plate utilizing threaded stud for positive belt tensioning - L50/200k Concentric locking regreasable bearings with extended lube lines - Belt guard - Lifting lugs - Adjustable mounting feet.

**MOTOR POSITION CHART
 (View Facing Outlet)**

Mounting positions are field adjustable.

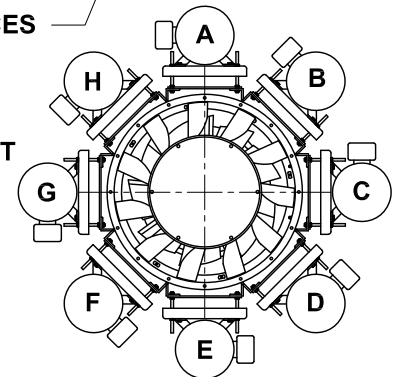

DIMENSION DATA

Size	A	B	C	D	E	F	G	H	Shaft Diameter	Max Motor Frame	Ship Wt.
180	25-5/8	29-1/4	28-5/8	15-1/2	46-1/4	22-7/8	23-11/16	7/16	1-7/16	254T	391
202	28-3/4	31-13/16	31-3/4	17-1/4	49-15/16	24-1/4	26-1/4	7/16	1-11/16	256T	478
225	31-15/16	33-13/16	34-15/16	19	55-13/16	26-7/8	28-1/4	7/16	1-15/16	284T	599
245	34-3/4	35-13/16	37-3/4	20-1/2	59	29	29-5/8	7/16	1-15/16	286T	704
270	38-5/16	38	41-5/16	22-7/16	62-7/8	31	31-13/16	7/16	2-3/16	286T	810
300	42-1/2	37-13/16	45-1/2	24-3/4	68-1/16	33-3/4	31-5/8	7/16	2-3/16	286T	921
330	46-3/4	40-1/8	49-3/4	27	74-13/16	36-3/4	33-15/16	7/16	2-7/16	324T	1130
365	51-3/4	44	54-3/4	29-13/16	80-1/4	40-1/2	38-1/16	7/16	2-15/16	326T	1564
402	56-15/16	47-15/16	59-15/16	32-11/16	88-5/16	44	42-3/16	1/2	3-7/16	364T	1811
445	63-1/16	52-9/16	66-1/16	36	94-7/8	48-1/4	46-13/16	1/2	3-7/16	365T	2243
490	69-3/8	57-15/16	72-3/8	39-7/16	103-3/8	52-3/4	51-7/8	9/16	3-15/16	404T	2796
540	76-7/16	64-3/8	79-7/16	43-5/16	110-15/16	58	57-1/2	5/8	3-15/16	404T	3291
600	84-7/8	70-15/16	88-3/8	50	122-1/16	64	64-1/16	11/16	3-15/16	404T	-

ALL DIMENSIONS IN INCHES. WEIGHTS IN LBS., LESS MOTOR.