

DATE: _____

PROJECT: _____

LOCATION: _____



Tube Axial Drum Fan
Extruded Aluminum Propeller
Belt Drive

DIMENSION DATA

Size	A	B	C	D	E	F	G	H	J	Drum Ga.	Ship Wt.
24	21	27-1/2	1-1/2	17-1/8	20	16-1/8	5-1/4	16-5/16	9-3/4	12 ga.	147
30	25	33-1/2	1-1/2	22-1/8	22	18-1/8	5-1/4	16-5/16	9-3/4	12 ga.	224
36	30	39-1/2	1-1/2	22-1/8	25	21-1/8	6-3/4	17-13/16	12-3/4	12 ga.	315
42	31	45-3/4	1-5/8	22-1/8	29	21-1/8	6-3/4	17-13/16	12-3/4	10 ga.	390
48	33	52-3/4	2-1/8	22-1/8	31	21-1/8	6-3/4	17-13/16	12-3/4	10 ga.	470
54	38	58-3/4	2-1/8	27	35	24-1/8	10	19-9/16	17	10 ga.	585
60	41	64-3/4	2-1/8	27	35	24-1/8	10	19-9/16	17	10 ga.	705

ALL DIMENSIONS IN INCHES. WEIGHTS IN LBS.

STANDARD CONSTRUCTION FEATURES:

Extruded aluminum propeller - Extended lube lines on bearings - Adjustable pitch drives through 5 HP motor - Painted steel housing - Permanently lubricated ball bearing motors - Static resistant belts - Corrosion resistant fasteners - American made bearings rated at 200,000 hours average life - All fans factory adjusted to specified fan RPM.

ACCESSORIES

1. DISCONNECT SWITCH
2. INLET/OUTLET GUARD
3. FLOOR MOUNTING FEET
4. HANGING BRACKETS (V OR H)
5. INLET BELL
6. WEATHER COVER
7. BELT GUARD
8. SPECIAL

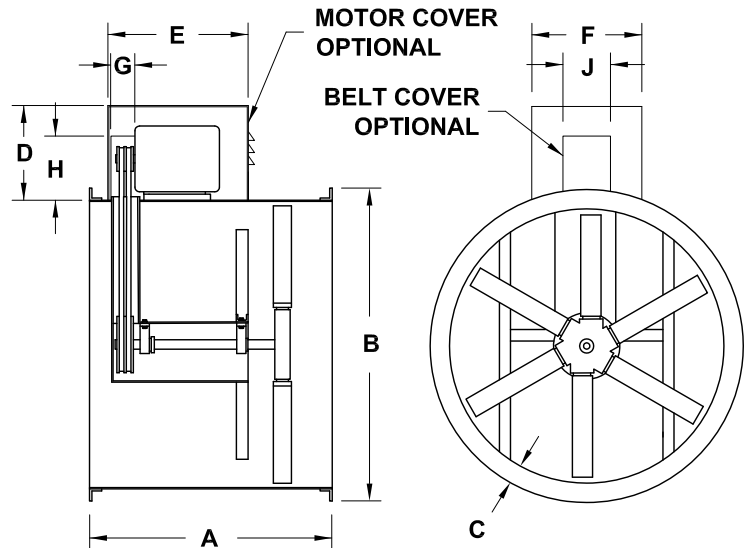

QTY	MARK	CATALOG NUMBER	FAN INFORMATION			MOTOR INFORMATION					ACCESSORIES	
			CFM	SP	RPM	HP	VOLTS	HZ	PH	TYPE		

LARGEST MOTOR SHIPPED MOUNTED: ODP (OPEN DRIP-PROOF) 5 HP; 2 SP (2 SPEED) 2 HP; X-PRF (EXPLOSION PROOF) 2 HP; TEFC (TOTALLY ENCLOSED FAN COOLED) 3 HP.