



This publication contains supplemental wiring instructions for units incorporating EC motors. Carefully read this publication prior to any installation or maintenance procedure.

Loren Cook catalogs provide additional information describing the equipment, fan performance, available accessories, and specification data. For additional safety information, refer to AMCA Publication 410-96, Safety Practices for Users and Installers of Industrial and Commercial Fans.

All of the publications listed above can be obtained from Loren Cook Company by phoning (417)869-6474, extension 166; by FAX at (417)832-9431; or by e-mail at info@lorencook.com. For information on special equipment, contact Loren Cook Company Customer Service Department at (417)869-6474.

TYPE M - EC MOTOR PART NUMBERS 100179, 100180, 100181, 100182

FAN-MOUNTED SPEED CONTROL

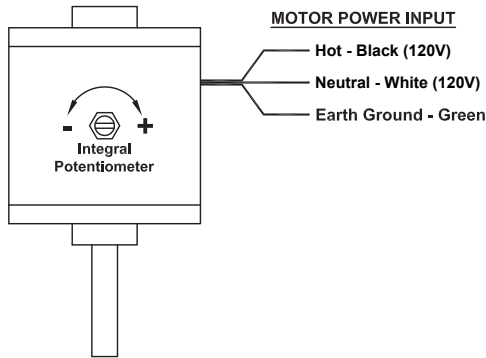

EXTERNAL SIGNAL 0-10VDC SPEED CONTROL

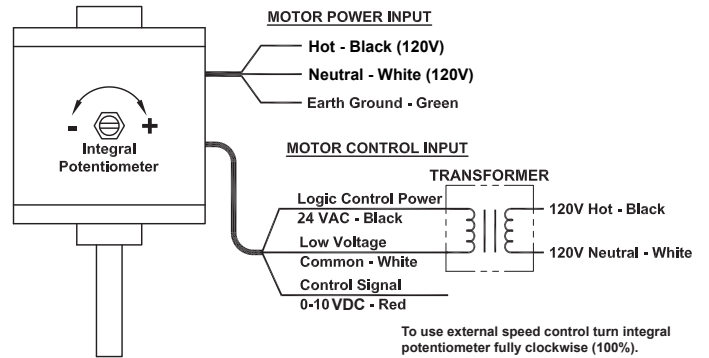

TYPE M1 - EC MOTOR PART NUMBERS 615273, 615278, 615271, 100218, 100220

FAN-MOUNTED SPEED CONTROL

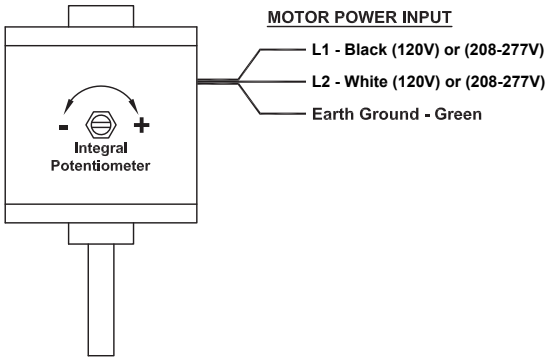

EXTERNAL SIGNAL 0-10VDC SPEED CONTROL

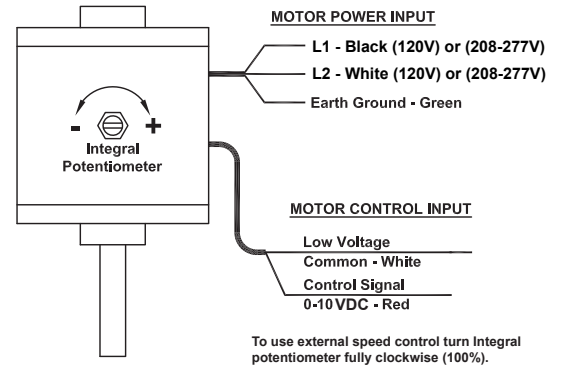

TYPE N - EC MOTOR PART NUMBERS 100201, 100202, 100203, 100214

FAN-MOUNTED SPEED CONTROL

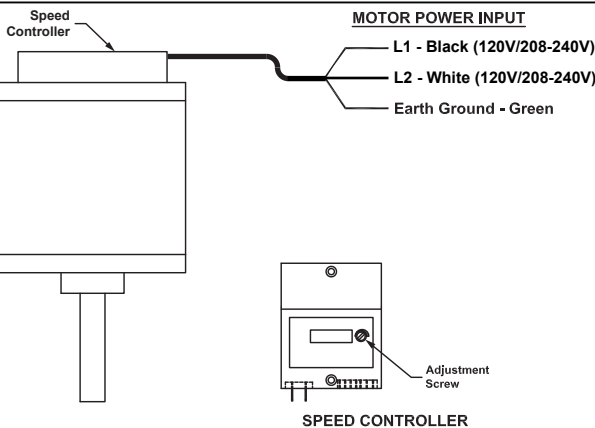

EXTERNAL SIGNAL 0-10VDC SPEED CONTROL

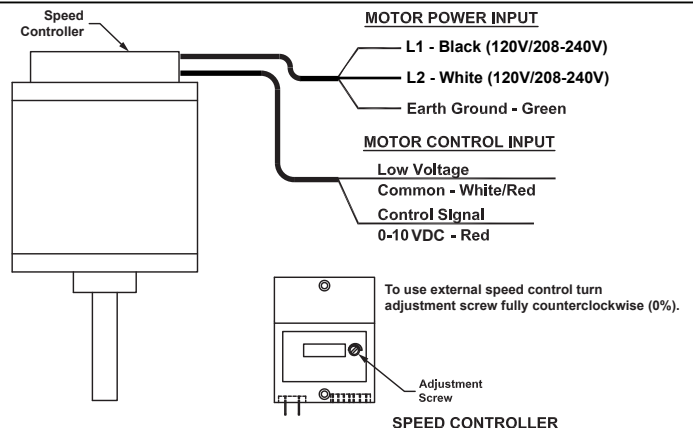

TYPE P - EC MOTOR PART NUMBERS 100175, 615267, 615269

FAN-MOUNTED SPEED CONTROL

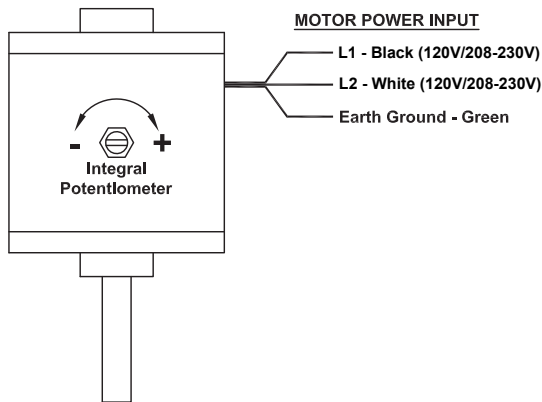

EXTERNAL SIGNAL 0-10VDC SPEED CONTROL

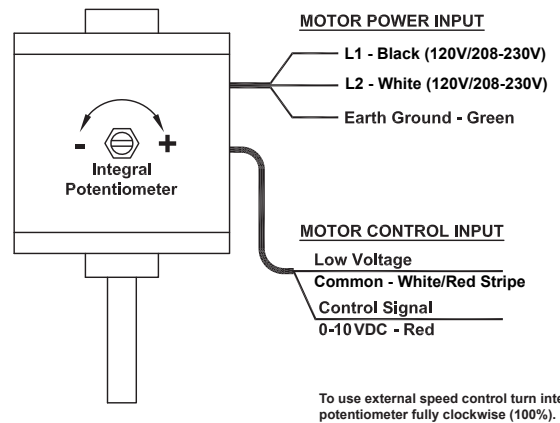

TYPE R - EC MOTOR PART NUMBER 100200

FAN-MOUNTED SPEED CONTROL

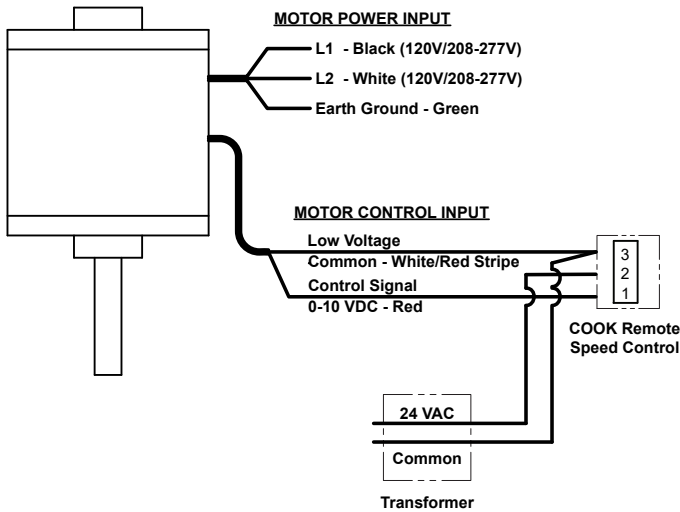

EXTERNAL SIGNAL 0-10VDC SPEED CONTROL

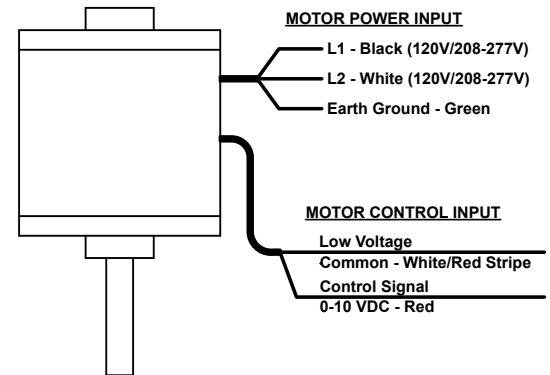

TYPE T - EC MOTOR PART NUMBER 100222

FAN-MOUNTED SPEED CONTROL

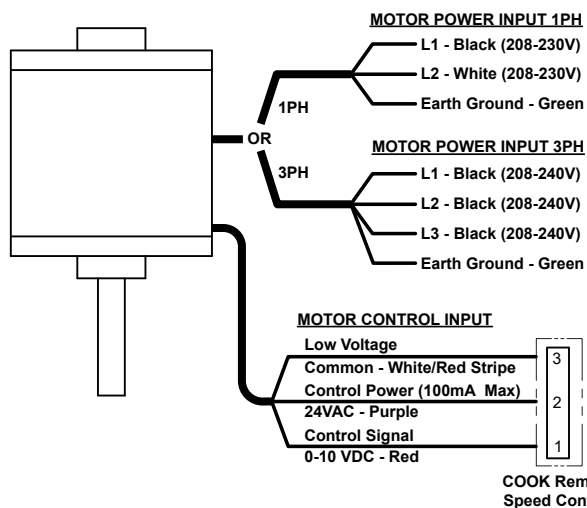

EXTERNAL SIGNAL 0-10VDC SPEED CONTROL

