



This publication contains the installation, operation and maintenance instructions for standard units of the SQI: *Square Centrifugal Inline Fans*.



Carefully read this publication and any supplemental documents prior to any installation or maintenance procedure.

Loren Cook catalog, *SQI*, provides additional information describing the equipment, fan performance, available accessories and specification data.

For additional safety information, refer to AMCA Publication 410-96, *Safety Practices for Users and Installers of Industrial and Commercial Fans*.

All of the publications listed above can be obtained from:

- lorencook.com
- info@lorencook.com
- 417-869-6474 ext. 166

For information and instructions on special equipment, contact Loren Cook Company at 417-869-6474.

Receiving and Inspection

Carefully inspect the fan and accessories for any damage and shortage immediately upon receipt of the fan.

- Turn the wheel by hand to ensure it turns freely and does not bind
- Inspect dampers for free operation of all moving parts
- Record on the *Delivery Receipt* any visible sign of damage

Handling

Lift the fan by the lifting holes.

NOTICE! Never lift by the shaft, motor or housing.



SQI-B

!WARNING

Rotating Parts & Electrical Shock Hazard:

Fans should be installed and serviced by qualified personnel only.

Disconnect electric power before working on unit (prior to removal of guards or entry into access doors).

Follow proper lockout/tagout procedures to ensure the unit cannot be energized while being installed or serviced.

A disconnect switch should be placed near the fan in order that the power can be swiftly cut off, in case of an emergency and in order that maintenance personnel are provided complete control of the power source.

Grounding is required. All field-installed wiring must be completed by qualified personnel. All field installed wiring must comply with National Electric Code (NFPA 70) and all applicable local codes.

Fans and blowers create pressure at the discharge and vacuum at the inlet. This may cause objects to get pulled into the unit and objects to be propelled rapidly from the discharge. The discharge should always be directed in a safe direction and inlets should not be left unguarded. Any object pulled into the inlet will become a projectile capable of causing serious injury or death.

When air is allowed to move through a non-powered fan, the impeller can rotate, which is referred to as windmilling. Windmilling will cause hazardous conditions due to unexpected rotation of components. Impellers should be blocked in position or air passages blocked to prevent draft when working on fans.

Friction and power loss inside rotating components will cause them to be a potential burn hazard. All components should be approached with caution and/or allowed to cool before contacting them for maintenance.

Under certain lighting conditions, rotating components may appear stationary. Components should be verified to be stationary in a safe manner, before they come into contact with personnel, tools or clothing.

Failure to follow these instructions could result in death or serious injury.

The attachment of roof mounted fans to the roof curb as well as the attachment of roof curbs to the building structure must exceed the structural requirements based on the environmental loading derived from the applicable building code for the site. The local code official may require variations from the recognized code based on local data. The licensed engineer of record will be responsible for prescribing the correct attachment based on construction materials, code requirements and environmental effects specific to the installation.

Storage

If fan is stored for any length of time, prior to installation, completely fill bearings with grease or moisture-inhibiting oil. Refer to pages 4-5. Store the fan in its original crate and protect from dust, debris, and weather. To maintain good working condition of a SQI when it's stored outdoors, or on a construction site follow the additional steps below.

- Cover the inlet and outlet, and belt tunnel opening to prevent accumulation of dust and moisture in the housing
- Periodically rotate the wheel and operate dampers (if supplied) to keep a coating of grease on all internal bearing parts
- Periodically inspect the unit to prevent damaging conditions

Installation

To prevent damage to the fan during shipping, motors 5HP and larger, and extremely heavy motors (cast iron or severe duty) are shipped loose and must be field mounted by bolting the motor on the motor mounting plate in the existing mounting slots.

Wiring Installation

NOTICE! All wiring should be in accordance with local ordinances and the National Electrical Code, NFPA 70. Ensure the power supply (voltage, frequency, and current carrying capacity of wires) is in accordance with the motor nameplate. Refer to Wiring Diagrams, page 3-4.



Direct Drive

Wire the electrical box on the blower housing.

Belt Drive

The motor can be wired directly since the motor is external to the fan.

Leave enough slack in the wiring to allow for motor movement when adjusting belt tension. Some fractional motors have to be removed in order to make the connection with the terminal box at the end of the motor. To remove motor, remove bolts securing motor base to power assembly. Do not remove motor mounting bolts.

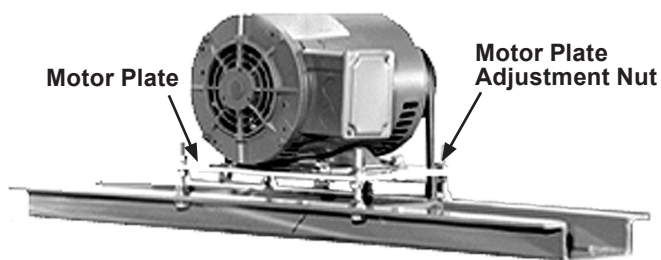

Belt and Pulley Installation

Belt tension is determined by the sound the belts make when the fan is first started. Belts will produce a loud squeal which dissipates after the fan is operating at full capacity. If the belt tension is too tight or too loose, lost efficiency and possible damage can occur.

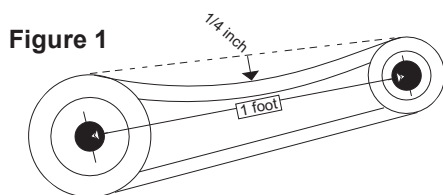

Do not change the pulley pitch diameter to change tension. This will result in a different fan speed.

1. Loosen motor plate adjustment nuts on stud bolts and move motor plate in order that the belts can easily slip into the grooves on the pulleys. Never pry, roll, or force the belts over the rim of the pulley.
2. Adjust the motor plate until proper tension is reached. For proper tension, a deflection of approximately 1/4" per foot of center distance should be obtained by firmly pressing the belt. Refer to Figure 1.
3. Lock the motor plate adjustment nuts in place.
4. Ensure pulleys are properly aligned. Refer to Figure 2.

Figure 2

Tolerance

Center Distance	Max. Gap
Up through 12"	1/16"
12" through 48"	1/8"
Over 48"	1/4"

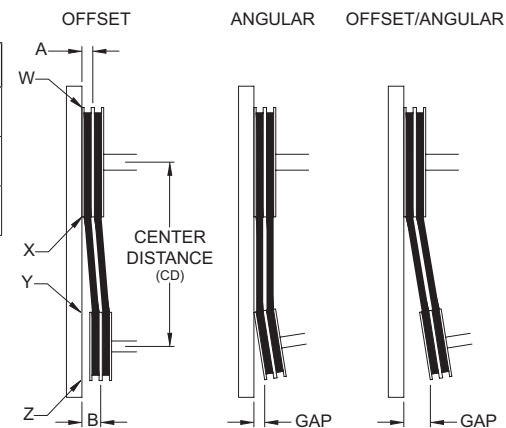

Pulley Alignment

Pulley alignment is adjusted by loosening the motor pulley setscrew and by moving the motor pulley on the motor shaft.

Figure 2 indicates where to measure the allowable gap for the drive alignment tolerance. All contact points (indicated by WXYZ) are to have a gap less than the tolerance shown in the table. When the pulleys are not the same width, the allowable gap must be adjusted by half of the difference in width. Figure 3 illustrates using a carpenter's square to adjust the position of the motor pulley until the belt is parallel to the longer leg of the square.

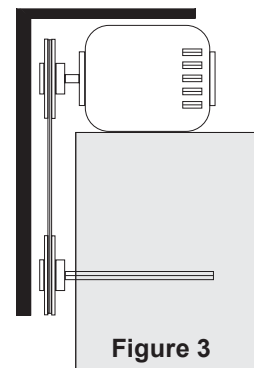

Final Installation Steps

1. Ensure that all accessories are installed.
2. Ensure that the blower is secured to ductwork.
3. Inspect wheel-to-inlet clearance. Ensure wheel does not rub against the inlet.
4. Test the fan to ensure the rotation of the wheel is the same as indicated by the rotation label.
5. Inspect for correct amperage with an ammeter and correct voltage with a voltmeter.

NOTICE! Do not allow the fan to run in the wrong direction. This will overheat the motor and cause serious damage. For 3-phase motors, if the fan is running in the wrong direction, check the control switch. It is possible to interchange two leads at this location so that the fan is operating in the correct direction.



Operation

Pre-Start Checks

1. Lock out all the primary and secondary power sources.
2. Inspect and tighten fasteners and setscrews, particularly fan mounting and bearing fasteners. Refer to *Recommended Torque* chart.
3. Inspect belt tension and pulley alignment.
4. Inspect motor wiring.
5. Ensure fan and ductwork are clean and free of debris.
6. Close and secure all access doors.
7. Restore power to the fan.

Start Up

Turn the fan on. In variable speed units, set the fan to its lowest speed and inspect for the following:

- Direction of rotation
- Excessive vibration
- Unusual noise
- Bearing noise
- Improper belt alignment or tension (listen for squealing)
- Improper motor amperage or voltage



If a problem is discovered, immediately shut the fan off. Lock out all electrical power and check for the cause of the trouble. See Troubleshooting.

Inspection

Inspection of the fan should be conducted at the first **30 minute, 8 hour and 24 hour** intervals of satisfactory operation. During the inspections, stop the fan and inspect as follows.

30 Minute Interval

Inspect bolts, setscrews, and motor mounting bolts. Adjust and tighten as necessary.

8 Hour Interval

Inspect belt alignment and tension. Adjust and tighten as necessary.

24 Hour Interval

Inspect belt tension. Adjust and tighten as necessary.

Wiring Diagrams

Vari-Flow Motors

For EC or VF see EC Motor Wiring supplement. For VF2 see PM wiring supplement.

Single Speed, Single Phase Motor

When ground is required, attach to ground A or B with no. 6 thread forming screw. To reverse, interchange T-1 and T-4.

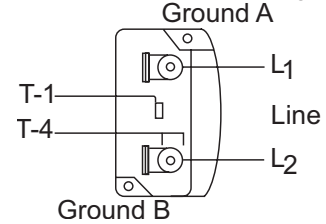

2 Speed, 2 Winding, Single Phase Motor

When ground required, attach to ground A or B with No. 6 thread forming screw. To reverse, interchange T-1 and T-4 leads.

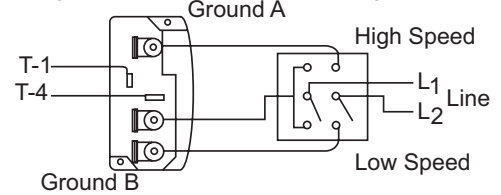

Single Speed, Single Phase, Dual Voltage

When ground required, attach to ground A or B with No. 6 thread forming screw. To reverse, interchange T-5 and J-10 leads.

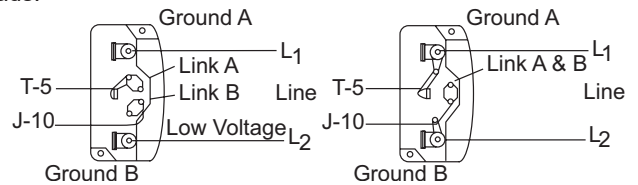

3-Phase, 9 Lead Motor

To reverse, interchange any two line leads.

Y-Connection

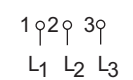
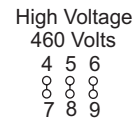
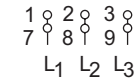
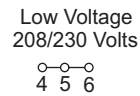

Delta-Connection

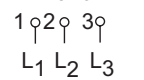
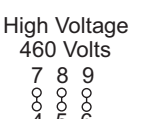
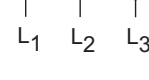
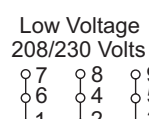

2 Speed, 1 Winding, 3 Phase Motor

To reverse, interchange any 2 line leads. Motors require magnetic control.

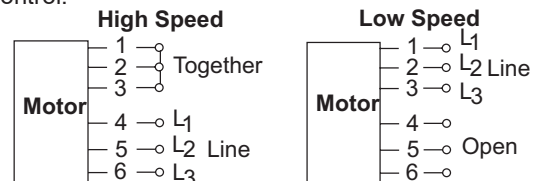

2 Speed, 2 Winding, 3 Phase

To reverse: High Speed-interchange leads T11 and T12. Low Speed-interchange leads T1 and T2. Both Speeds-interchange any two line leads.

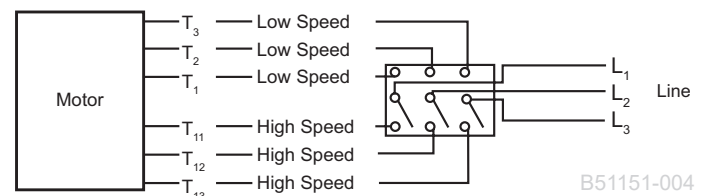

Typical Damper Motor Schematic

For 3 phase, damper motor voltage should be the same between L₁ and L₂. For single phase application, disregard L₃.

*Damper motors may be available in 115, 230 and 460 volt models. The damper motor nameplate voltage should be verified prior to connection.

**A transformer may be provided in some installations to correct the damper motor voltage to the specified voltage.

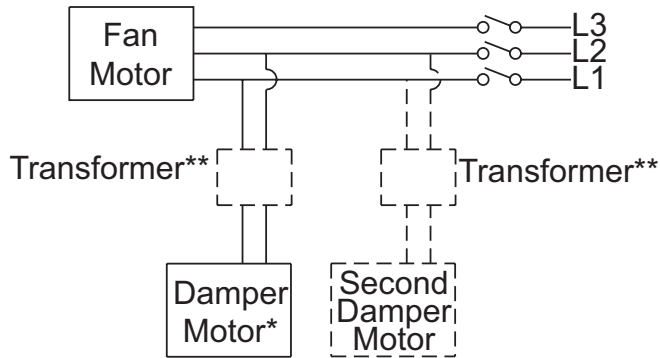

SQI-D 70-90

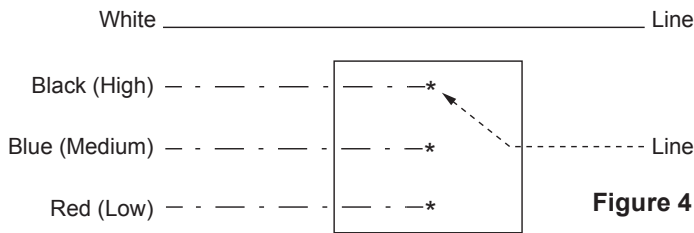
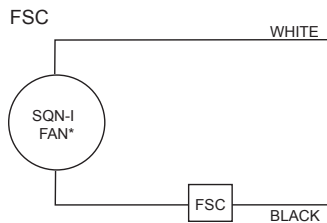

Figure 4

NOTE: Insulate unused leads separately; leads are located at the motor inside the unit.



*See SQI Wiring Diagram for correct lead.

Maintenance

Establish a schedule for inspecting all parts of the fan. The frequency of inspection depends on the operating conditions and location of the fan.

Inspect fans exhausting corrosive or contaminated air within the first month of operation. Fans exhausting contaminated air (airborne abrasives) should be inspected every three months.

Yearly inspections are recommended for fans exhausting non-contaminated air. **It is recommended the following inspections be conducted twice per year.**

1. Inspect bolts and setscrews for tightness. Tighten as necessary. Refer to *Recommended Torque* chart.
2. Inspect belt wear and alignment. Replace worn belts with new belts and adjust alignment as needed. Refer to *Belt and Pulley Installation*.
3. Bearings should be inspected as recommended in the *Conditions* chart.
4. Inspect for cleanliness. Clean exterior surfaces only. Removing dust and grease on motor housing assures proper motor cooling.

Recommended Torque for Setscrews/Bolts (IN-LB)

Size	Key Hex Across Flats	Setscrews		Hold Down Bolts	
		Recommended Torque		Size	Recommended Torque
		Min.	Max.		
#8	5/64"	15	21	3/8"-16	324
#10	3/32"	27	33	1/2"-13	780
1/4	1/8"	70	80	5/8"-11	1440
5/16	5/32"	140	160	3/4"-10	2400
3/8	3/16"	250	290	7/8"-9	1920
7/16	7/32"	355	405	1"-8	2700
1/2	1/4"	560	640	1-1/8"-7	4200
5/8	5/16"	1120	1280	1-1/4"-7	6000
3/4	3/8"	1680	1920	-	-
7/8	1/2"	4200	4800	-	-
1	9/16"	5600	6400	-	-

Fan Bearings

NOTICE! The fan bearings are provided prelubricated. Any specialized lubrication instructions on fan labels supersedes information provided herein. Bearing grease is a petroleum lubricant in a lithium base conforming to an NLGI #2 consistency. If user desires to utilize another type of lubricant, they take responsibility for flushing bearings and lines, and maintaining a lubricant that is compatible with the installation.



Bearings should be relubricated in accordance with the condition chart below.

For best results, lubricate the bearing while the fan is in operation. Pump grease in slowly until a slight bead forms around the bearing seals. Excessive grease can damage seal and reduce life through excess contamination and/or loss of lubricant.

In the event that the bearing cannot be seen, use no more than three injections with a hand operated grease gun.

Conditions Chart

RPM	Temp °F	Greasing Interval
Up to 1000	-30 to 120	6 months
	120 to 200	2 months
1000 to 3000	-30 to 120	3 months
	120 to 200	1 month
Over 3000	-30 to 120	1 month
	120 to 200	2 weeks
Any Speed	< -30	Consult Factory
Any Speed	> 200	1 week

For moist or otherwise contaminated installations, divide the interval by a factor of three. For vertical shaft installations, divide the interval by a factor of two.

Motor Bearings

Motors are provided with prelubricated bearings. Any lubrication instructions shown on the motor nameplate supersede instructions below.

Direct Drive 1050/1075, 1200, 1300 and 1500 RPM units use a prelubricated sleeve bearing that has a oil saturated wicking material surrounding it. The initial factory lubrication is adequate for up to 10 years of operation under normal conditions. However, it is advisable to add lubricant after 3 years. Use only LIGHT grade mineral oil or SAE 10W oil up to 30 drops. If the unit has been stored for a year or more it is advisable to lubricate as directed above. For units in severe conditions, lubrication intervals should be reduced to half.

Motors without sleeve bearings (as previously described) will have grease lubricated ball or roller bearings. Motor bearings without provisions for relubrication will operate

up to 10 years under normal conditions with no maintenance. In severe applications, high temperatures or excessive contaminants, it is advisable to have the maintenance department disassemble and lubricate the bearings after 3 years of operation to prevent interruption of service.

For motors with provisions for relubrication, follow intervals of the following table.

Relubrication Intervals

Service Conditions	NEMA Frame Size					
	Up to & including 184T		213T-365T		404T & larger	
	1800 RPM and less	Over 1800 RPM	1800 RPM and less	Over 1800 RPM	1800 RPM and less	Over 1800 RPM
Standard	3 years	6 months	2 years	6 months	1 year	3 months
Severe	1 year	3 months	1 year	3 months	6 months	1 months

Motors are provided with a polyurea mineral oil NGLI #2 grease. All additions to the motor bearings are to be with a compatible grease such as Exxon Mobil Polyrex EM and Chevron SRI.

The above intervals should be reduced to half for vertical shaft installations.

Motor Services

Should the motor prove defective within a one-year period, contact your local Loren Cook representative or your nearest authorized electric motor service representative.

Changing Fan Speed

All belt driven fans with motors up to and including 5HP are equipped with variable pitch pulleys.

1. Loosen setscrew on motor pulley
2. Open or close the groove facing to change the pitch diameter.

Speed Reduction: Open the pulley in order that the belt rests deeper in the groove.

Speed Increase: Close the pulley in order that the belt rests higher in the groove. Ensure RPM limits of the fan and the horsepower limits of the motor are maintained.

3. Retighten pulley setscrew on one of the flat areas of the motor shaft.
4. After the adjustment is made, check for proper belt tension. See *Belt and Pulley Installation*.

Maximum RPM

SQI-B Size	Maximum RPM	SQI-HP Size	Maximum RPM
90	3341	135	2624
120	2966	150	2692
135	2460	165	2687
150	2209	180	1958
165	2158	195	1901
180	1814	210	1702
195	1590	225	1797
210	1417	245	1775
225	1490	270	1525
245	1485	300	1271
270	1244	330	1208
300	1041	365	1000
330	992	402	995
365	833		
402	714		

Pulley and Belt Replacement

1. Remove pulleys from their respective shafts.
2. Clean the motor and fan shafts.
3. Clean bores of pulleys and coat the bores with heavy oil.
4. Remove grease, rust or burrs from the pulleys and shafts.
5. Remove burrs from shaft by sanding.
6. Place fan pulley on fan shaft and motor pulley on its shaft.

NOTICE! Do not hammer the pulleys onto the shafts because this may damage the bearings.

7. Tighten in place.
8. Install belts on pulleys and align as described in *Belt and Pulley Installation*.

Bearing Replacement

The SQI-B fan bearings are pillow block ball bearings.

1. Remove outer access door.
2. Remove bolts/screws to inner housing access doors. Open and remove the inner access door to reveal bearings.
3. Remove the old bearing.
4. Remove any burrs from the shaft by sanding.
5. Slide new bearings onto the shaft to the desired location and loosely mount bearings onto the bearing support. Bearing bolts and setscrews should be loose enough to allow shaft positioning.
6. Correctly position the wheel and tighten the bearing bolts securely to the bearing plate.
7. Align setscrews bearing to bearing and secure tightly to the shaft.

NOTICE! Never tighten both pairs of setscrews before securing bearing mounting bolts. This may damage the shaft.

8. Inspect the wheel position again. If necessary, readjust by loosening the bearing bolts and setscrews and repeat from step 5.

Wheel Replacement

1. Drill two 1/4" diameter holes, 180° apart centered approximately between the shaft and the outside diameter of the hub, 3/8" to 1/2" in depth.
2. Tap 1/4" holes to 5/16" thread with a 5/16" hole tap. Do not drill or tap greater than recommended.
3. Screw the puller arms to the full depth of the threads into the tapped holes. Align center of the puller with the center of the shaft. Ensure all setscrews in the hub, normally two, are fully removed.
4. Slowly remove wheel from the shaft.

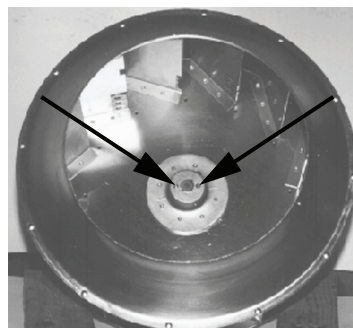

Drilled Hole Location

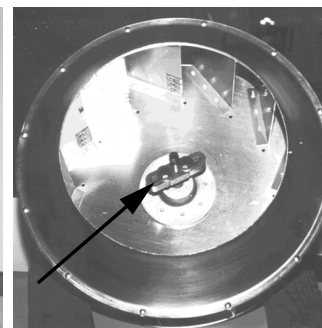

Wheel Puller

Recommended Puller

Lisle No. 45000 Steering Wheel Puller. This puller is available at most automotive parts retail outlets.

Wheel-to-Inlet Clearance

The correct wheel-to-inlet clearance is critical to proper fan performance. This clearance should be verified before initial start-up since rough handling during shipment could cause a shift in fan components. Refer to wheel/inlet drawing for correct overlap.

Adjust the overlap by loosening the wheel hub and moving the wheel along the shaft to obtain the correct value.

A uniform radial gap (space between the edge of the cone and the edge of the inlet) is obtained by loosening the inlet cone bolts and repositioning the inlet cone.

Wheel/Inlet Overlap

Size	Overlap
70 - 165	3/16"
180 - 245	1/4"
270 - 300	5/16"
330 - 365	3/8"
402	7/16"

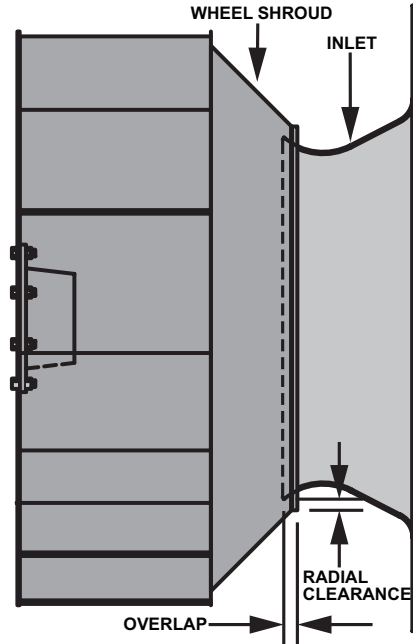

Troubleshooting

Problem and Potential Cause

Low Capacity or Pressure:

- Incorrect direction of rotation. Make sure the fan rotates in same direction as the arrows on the motor or belt drive assembly.
- Poor fan inlet conditions. There should be a straight clear duct at the inlet.
- Improper wheel alignment.

Excessive Vibration and Noise:

- Damaged or unbalanced wheel.
- Belts too loose; worn or oily belts.
- Speed too high.
- Incorrect direction of rotation. Make sure the fan rotates in same direction as the arrows on the motor or belt drive assembly.
- Bearings need lubrication or replacement.
- Fan surge.
- For direct drive, make sure hub setscrew, if available, is tightened down on motor shaft or on key. For direct drive units with bushing, the hub setscrew, if available, needs to go through the bushing and then tightened down on the motor shaft or on key.

Overheated Motor:

- Motor improperly wired.
- Incorrect direction of rotation. Make sure the fan rotates in same direction as the arrows on the motor or belt drive assembly.
- Cooling air diverted or blocked.
- Improper inlet clearance.
- Incorrect fan RPMs.

Overheated Bearings:

- Improper bearing lubrication
- Excessive belt tension.

Parts List

SQI-D

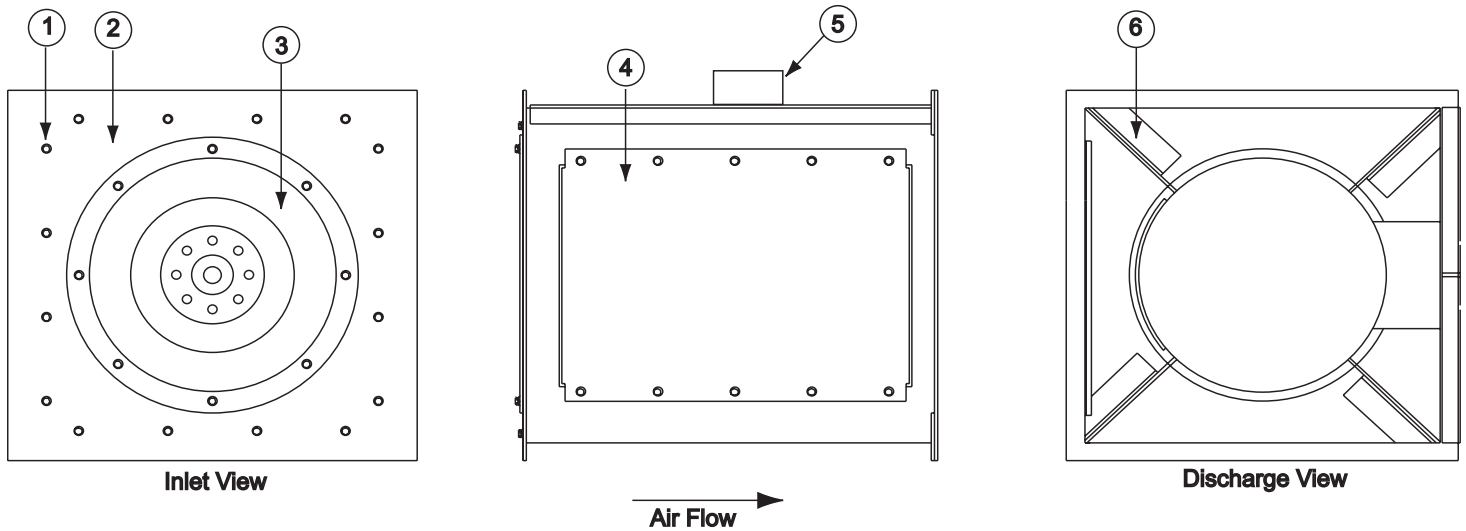

Part No.	Sizes 70-90	Size 90-135	Sizes 150-165
1	Hex Bolts	Hex Bolts	Hex Bolts
2	Inlet Panel	Inlet Panel	Inlet Panel
3	-	Inlet	Inlet
4	Access Door	Access Door	Access Door
5	Electric Box	Electric Box	Electric Box
6	Straightening Vanes	Straightening Vanes	Straightening Vanes

Not Shown

7	Wheel Assembly	Wheel Assembly	Wheel Assembly
8	-	-	Slot Cover
9	Motor	Motor	Motor
10	Motor Plate	Motor Plate	Motor Plate

SQI-B

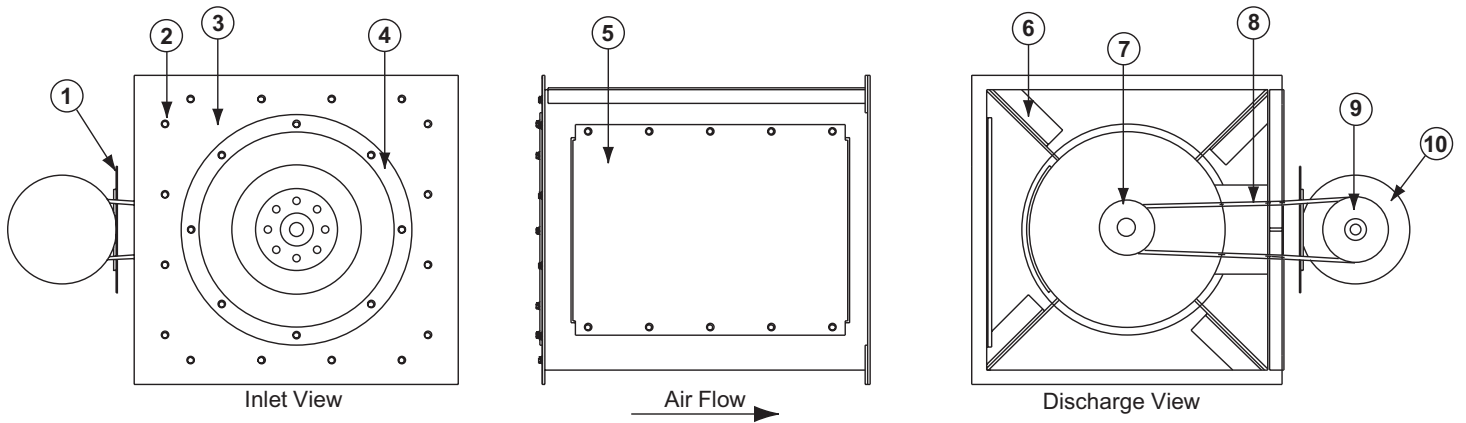

Part No.	Description
1	Motor Plate
2	Hex Bolt
3	Inlet Panel
4	Inlet
5	Access Door
6	Straightening Vane
7	Driven Sheave
8	Belt Set
9	Driver Sheave
10	Motor

Not Shown

11	Wheel Assembly
12	Slot Cover
13	Bearings
14	Shaft

Limited Warranty

Loren Cook Company warrants that your Loren Cook fan was manufactured free of defects in materials and workmanship, to the extent stated herein. For a period of one (1) year after date of shipment, we will replace any parts found to be defective without charge, except for shipping costs which will be paid by you. This warranty is granted only to the original purchaser placing the fan in service. This warranty is void if the fan or any part thereof has been altered or modified from its original design or has been abused, misused, damaged or is in worn condition or if the fan has been used other than for the uses described in the company manual. This warranty does not cover defects resulting from normal wear and tear. To make a warranty claim, notify Loren Cook Company, General Offices, 2015 East Dale Street, Springfield, Missouri 65803-4637, explaining in writing, in detail, your complaint and referring to the specific model and serial numbers of your fan. Upon receipt by Loren Cook Company of your written complaint, you will be notified, within thirty (30) days of our receipt of your complaint, in writing, as to the manner in which your claim will be handled. If you are entitled to warranty relief, a warranty adjustment will be completed within sixty (60) business days of the receipt of your written complaint by Loren Cook Company. This warranty gives only the original purchaser placing the fan in service specifically the right. You may have other legal rights which vary from state to state. For fans provided with motors, the motor manufacturer warrants motors for a designated period stated in the manufacturer's warranty. Warranty periods vary from manufacturer to manufacturer. Should motors furnished by Loren Cook Company prove defective during the designated period, they should be returned to the nearest authorized motor service station. Loren Cook Company will not be responsible for any removal or installation costs.



LOREN COOK COMPANY

Corporate Offices: 2015 E. Dale St. Springfield, MO 65803
Phone 417-869-6474 | Fax 417-862-3820 | lorencook.com