

MARK: _____

PROJECT: _____

DATE: _____

Accessory Data Sheet
Gravity Isolation Damper
Counterbalanced
for QMX Mixing Box
Aluminum

STANDARD CONSTRUCTION FEATURES:

- Frame: 6063T5 extruded aluminum with .125" minimum wall thickness.
- Blades: 6063T5 extruded aluminum, .070" wall thickness with extruded vinyl edge seals.
- Bearings: Zytel.
- Linkage: 1/8" x1/2" aluminum tiebars.
- Counterbalance: Zinc plated bar on blades (except top blade). Adjustable for final "on the job" setting.
- Temperature Limits: -40°F and +200°F.
- Finish: Air-dry enamel coating to match fan color.

OPTIONAL CONSTRUCTION FEATURES:

- Air-dry epoxy finish.

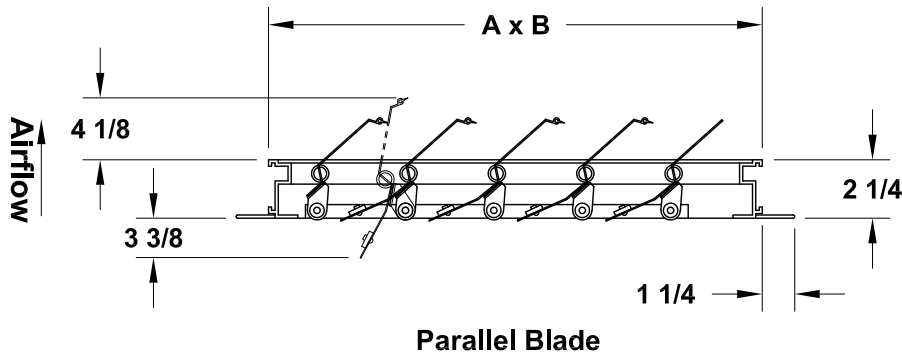
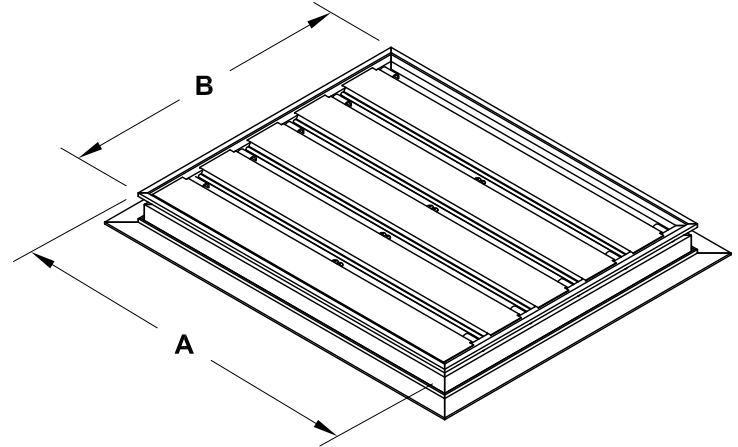
DIMENSION DATA

Qty	Mark	Size	A	B	No. Panels	Unit Wt.
		90	24-1/2	18	1	16
		120	24-1/2	18	1	16
		135	24-1/2	18	1	16
		150	26-1/2	20	1	19
		165	28-1/2	22	1	23
		180	30-1/2	24	1	26
		202	34-1/2	26-1/2	1	33
		225	38-1/2	30	1	41
		245	40-1/2	32	1	46
		270	44-1/2	36	1	57
		300	48-1/2	40	2	69
		330	52-1/2	44	2	82
		365	58-1/2	50	2	103
		402	63-1/2	55	4	123
		445	70-1/2	59	4	147
		490	76-1/2	65	4	175
		540	83-1/2	72	4	212
		600	92-1/2	86	4	280

Note: Gravity Isolation Dampers are not to be used on multiple mixing box configurations.