



# COOK Fiberglass Backdraft Damper

DATE: \_\_\_\_\_

PROJECT: \_\_\_\_\_

LOCATION: \_\_\_\_\_

**Accessory Data Sheet**  
**Counterbalanced**  
**Duct Mount**  
**FCED, FCEB, FCRUD, FCRUB**

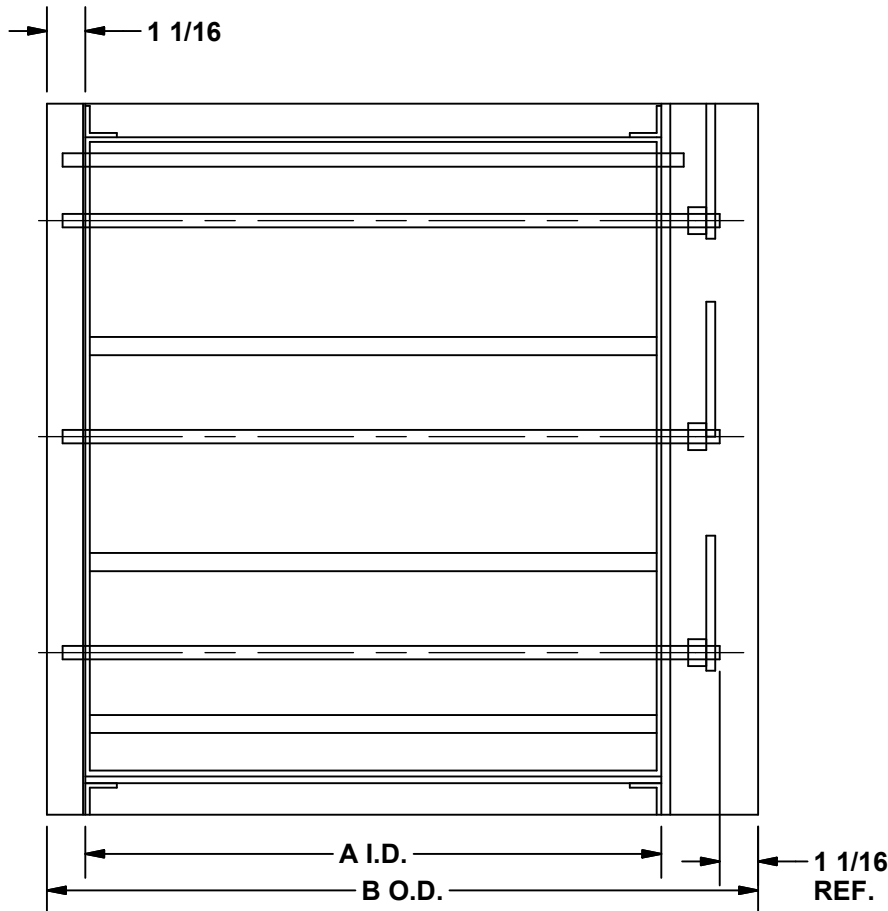

← AIR FLOW  
(VERTICAL UP ONLY)

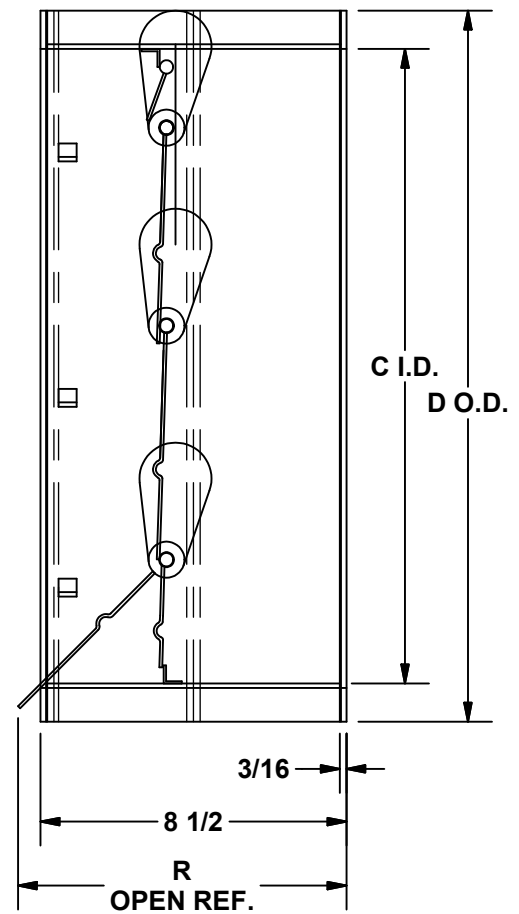

**Standard Construction Features:**

All parts are fiberglass and Isophthalic polyester resin - Joints are bonded with an industrial grade epoxy adhesive, having similar corrosion resistant properties as a polyester resin - Resin has a Class I flame spread rate of 25 or less - Surfaces are protected to be ultra-violet resistant.

**DIMENSION DATA**

Size	A	B	C	D	R
12	12	15 3/4	13 5/8	15 3/4	9 1/8
15	16	19 3/4	17 5/8	19 3/4	9 1/8
18	22	25 3/4	23 5/8	25 3/4	9 15/16
24	22	25 3/4	23 5/8	25 3/4	9 15/16

**Note:** For duct mount only. Will not fit in roof curb damper tray. Larger dampers made to order, per special quote

ALL DIMENSIONS IN INCHES. WEIGHTS IN LBS., LESS MOTOR.