

DATE: _____
 PROJECT: _____
 LOCATION: _____

**Low Silhouette
 Upblast
 Roof Gravity Unit**

DIMENSION DATA

Size	A Dia.	B	C	D	T Sq.	Steel Gauge			Roof Opening Square	Approx. Ship Wt.
						Base	Lower Drum	Wind Band		
24	31-3/8	30-1/8	27-1/2	3	36	14	14	18	31-1/2	214
30	37-3/8	36-1/8	33-1/2	3	42	14	14	18	37-1/2	269
36	43-3/8	40-1/8	37-1/2	3	48	14	14	18	43-1/2	321
42	49-3/8	47-1/8	44-1/2	3	54	14	14	18	49-1/2	395
48	55-3/8	52-1/8	49-1/2	3	60	14	14	16	55-1/2	497
54	61-3/8	48-1/8	45-1/2	3	66	14	12	16	61-1/2	504
60	67-3/8	53-1/8	50-1/2	3	72	14	12	16	67-1/2	587

ALL DIMENSIONS IN INCHES. WEIGHTS IN LBS.

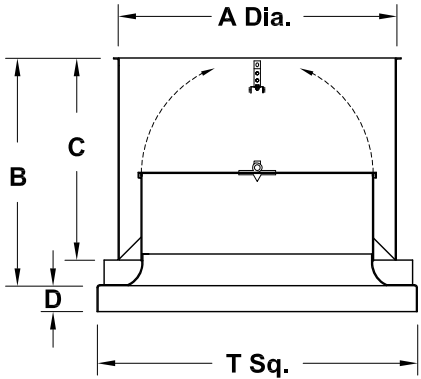

STANDARD CONSTRUCTION FEATURES:

All non-galvanized steel components finished with Lorenized coating -
 14 gauge spun steel venturi/curb cap - 14 gauge steel lower drum -
 Minimum 18 gauge steel wind band - Aluminum butterfly damper doors (24-36) -
 Galvanized steel damper doors (42-60) - Welded curb cap corners -
 Corrosion resistant fastners

ACCESSORIES

1. DISCHARGE GUARD
2. ALUMINUM DAMPERS
3. RCG GALVANIZED ROOF CURB
4. RCA ALUMINUM ROOF CURB
5. EPOXY COATING

QTY	MARK	CATALOG NUMBER	FAN INFORMATION			ACCESSORIES							
			CFM	SP	RPM								