

DATE: _____
 PROJECT: _____
 LOCATION: _____

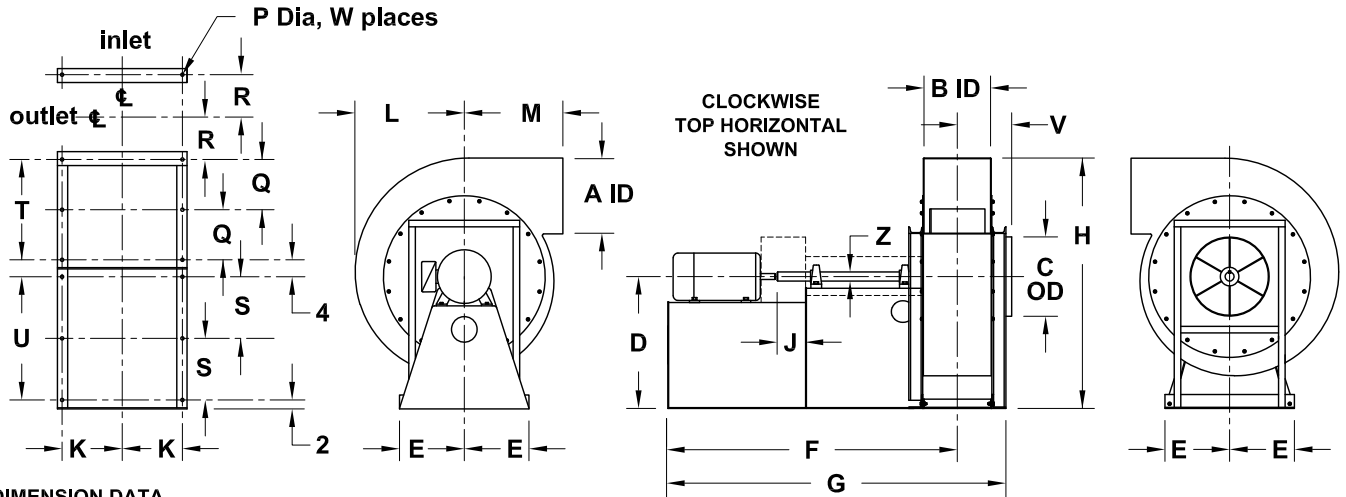

**Industrial Material Handler
 Arrangement 8**



DIMENSION DATA

Size	A	B	C	D	E	F*	G*	H	J	K	L	M	N	P	Q	R
70	6-5/8	5-7/8	7	14-1/4	9-11/16	49-15/16	55-1/8	24-13/16	4	9-3/16	9-11/16	8-5/16	10-9/16	9/16	-	4-1/4
90	8-7/16	7-1/2	9	15-1/4	9-11/16	53-9/16	59-9/16	28-3/4	4	9-3/16	12-5/16	10-5/8	13-1/2	9/16	-	5-1/16
110	10-3/8	9-1/8	11	18-3/4	9-11/16	57-3/4	65-5/8	35-3/16	4	9-3/16	15-1/16	13	16-7/16	9/16	8-1/4	6-1/2
130	12-3/16	10-7/8	13	21-3/4	11-3/4	61-7/16	70-1/8	41-3/16	5	11	17-13/16	15-3/8	19-7/16	11/16	8-3/8	7-3/8
150	14-1/16	12-9/16	15	25-1/4	13	69-1/4	78-13/16	47-5/8	5	12-1/2	20-5/8	17-3/4	22-3/8	11/16	10-3/4	8-7/32
170	16	14-1/4	17	28-1/4	13-7/8	74-3/16	84-5/8	53-5/8	6	13-1/8	23-3/4	20-1/8	25-3/8	11/16	10-3/4	9-1/16
190	17-13/16	15-7/8	19	31-1/4	15-5/16	77-13/16	89-1/8	59-1/2	6	14-9/16	25-15/16	22-7/16	28-1/4	11/16	11-3/8	9-15/16
210	19-3/4	17-9/16	21	34-1/2	16-9/16	85-1/2	97-5/8	65-3/4	6	15-13/16	28-1/2	23	31-1/4	11/16	12-3/4	10-21/32
230	21-5/8	19-1/4	23	37-1/2	18-13/16	89-3/8	103-1/2	71-13/16	7	17-9/16	31-1/4	26	34-5/16	13/16	13-7/16	12-5/16
260	24-7/16	21-3/4	26	41-3/4	20-5/8	94-3/16	108-15/16	82-15/16	7	19-3/8	35-1/8	29	41-3/16	13/16	13-7/8	13-9/16
290	27-5/16	24-1/4	29	46-1/2	22-1/2	96-13/16	113-7/16	92-1/2	8	21-1/4	39-1/2	31-3/4	45-7/8	13/16	14-3/8	14-13/16

Size	S*	T	U*	V	W	X	Y	Z		AA	BB	CC	Max. Motor Frame	Shipping Weight +++	
								SD+	HD++					Std Duty	Hvy Duty
70	-	14-7/8	24-7/8	6-3/16	6	10-1/8	9-1/4	1-3/16	1-7/16	8-13/16	8-3/8	13-3/8	184T	287	330
90	-	14-7/8	27-11/16	7	6	12-15/16	11-3/4	1-7/16	1-11/16	11-3/16	10-5/8	17-1/16	215T	382	439
110	14-3/8	16-1/2	28-3/4	8-13/16	8	15-3/4	14-7/16	1-7/16	1-15/16	13-3/4	13-1/16	20-13/16	256T	509	585
130	15-5/8	16-3/4	31-1/4	9-13/16	8	18-5/8	17	1-11/16	2-3/16	16-3/16	15-3/8	24-5/8	284T	607	770
150	16-3/4	21-1/2	33-1/2	10-11/16	8	21-1/2	19-3/4	1-15/16	2-7/16	18-7/8	18	28-3/8	286T	864	994
170	18-13/16	21-1/2	37-5/8	11-1/2	8	24-9/16	22-1/2	2-3/16	2-7/16	21-1/4	20-1/4	32-3/16	324T	1092	1255
190	19-9/16	22-3/4	39-1/8	12-5/16	8	27-1/8	24-7/8	2-7/16	2-15/16	23-3/4	22-5/8	35-13/16	364T	1353	1555
210	21-5/8	25-1/2	43-1/4	13-3/16	8	29-7/8	27-1/8	2-7/16	2-15/16	25-3/4	24-3/8	38-3/8	404T	1647	1894
230	22-1/8	26-7/8	44-1/4	15-1/8	8	32-13/16	29-13/16	2-11/16	3-7/16	28-5/16	26-13/16	42-5/8	405T	1974	2270
260	23-1/8	27-3/4	46-1/4	16-3/8	8	38-3/16	33-1/2	2-11/16	3-7/16	31-7/8	30-1/4	49-5/8	444T	2528	2907
290	23-5/8	28-3/4	47-1/4	17-5/8	8	42-11/16	37-5/8	2-15/16	3-7/16	35-3/4	33-7/8	54-7/8	444T	3157	3630

ALL DIMENSIONS IN INCHES. WEIGHTS IN LBS., LESS MOTOR. * F, G, S AND U VARY WITH MOTOR SIZE, CONSULT FACTORY FOR EXACT DIMENSIONS.
 +STANDARD DUTY, ++HEAVY DUTY, +++ BASED ON MH WHEEL.

