



COOK

VAD

DATE: _____

PROJECT: _____

LOCATION: _____



Fixed Pitch Vane Axial Vertical Wall Mount Direct Drive Arrangement 4

DIMENSION DATA

Size	A	B	C	D	E	F	G	H	J	K	L
18	18	21-5/16	19-3/4	10 Ga.	19	7/16	12	17	1	12-7/16	21
21	21	24-5/16	22-3/4	10 Ga.	20	7/16	12	18	1	13-15/16	24
26	26	30-7/16	28	7 Ga.	22	7/16	12	20	1	16-11/16	29-9/16
29	29	33-7/16	31	7 Ga.	25	7/16	12	23	1	18-1/4	32-5/8
36	36	40-7/16	38	7 Ga.	32	9/16	16	30	1	22-1/4	40-5/8
42	42	46-1/2	44-3/8	7 Ga.	37	9/16	16	34-3/4	1-1/8	25-3/16	46-3/4
48	48	53-1/2	50-1/2	7 Ga.	42	9/16	16	39-3/4	1-1/8	28-1/4	52-3/4
54	54	59-5/8	56-1/2	1/4	46	9/16	16	43-3/4	1-1/8	31-1/4	59
60	60	65-5/8	63-1/4	1/4	46	9/16	16	43-3/4	1-1/8	35-1/4	66

Size	M	N	TEFC Max. Mtr. Frame	Ship Wt.
18	8-1/2	7/16	143TC	111
21	10	7/16	145TC	143
26	12-13/16	7/16	184TC	220
29	14-5/16	7/16	215TC	290
36	18-5/16	9/16	254TC	356
42	21-3/8	9/16	284TC	567
48	24-3/8	9/16	364TC	645
54	27-1/2	9/16	405TC	991
60	31	9/16	445TC	1138

ALL DIMENSIONS IN INCHES. WEIGHTS IN LBS.

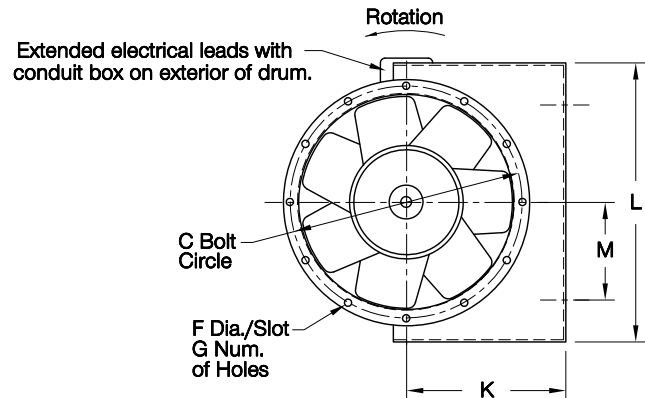

STANDARD CONSTRUCTION FEATURES:

All aluminum cast prop – Minimum 10 ga.
Lorenized steel housing with integral
straightening vanes – Extended
lube lines – C-face motor mount.

ACCESSORIES

1. INLET/OUTLET GUARD
2. INLET/OUTLET COMPANION FLANGE
3. VIBRATION ISOLATORS
4. INLET BELL
5. INLET/OUTLET CONE
6. INSPECTION DOOR
7. SOUND MUFFLER
8. HUB COVER

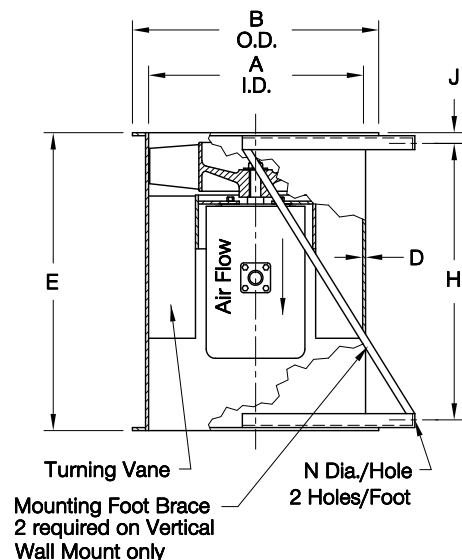

VA086R02