

MARK: _____

PROJECT: _____

DATE: _____



Centrifugal Square Inline Belt Drive

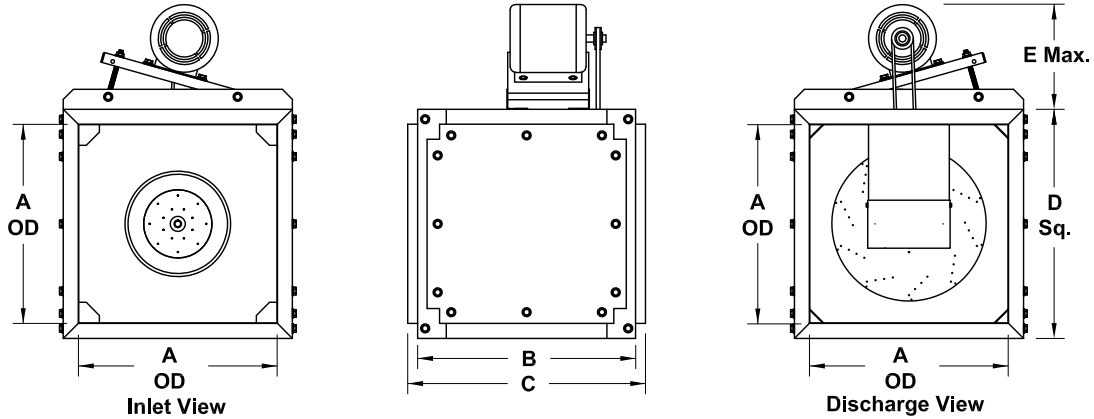

STANDARD CONSTRUCTION FEATURES:

All aluminum wheel - Galvanized steel housing - Three removable access doors - Closed cell neoprene gasketing - Inlet and discharge duct collars - Universal mounting feet - Regreasable bearings in a cast housing rated at 200,000 hours average life - Permanently lubricated ball bearing motor - Adjustable pitch drives through 5 HP - All fans factory adjusted to specified fan RPM - Transit tested packaging.

DIMENSION DATA

Size	A	B	C	D Sq.	E	Housing Gauge	Max Mtr Frame	Ship Wt.
60	12	20	22	14	12-1/2	18	143T	80
70	12	20	22	14	12-1/2	18	143T	80
80	12	20	22	14	12-1/2	18	143T	80
100	12	20	22	14	12-1/2	18	143T	80
120	16	20	22	18-7/16	12-1/2	18	145T	100
135	18	20-1/4	22-1/4	20-3/4	12-1/2	18	145T	125
150	20	21-7/8	23-7/8	23	12-3/4	18	145T	150
165	22	25	27	25-5/16	14-3/4	18	182T	175
180	24	28	30	27-5/8	14-3/4	16	182T	200
195	26	30-1/4	32-1/4	29-15/16	15	16	182T	225
210	28	32	35	31-1/4	15	16	182T	250
225	30	34-1/4	37-1/4	33-1/2	15-1/4	16	184T	300
245	33	34	38	36	17-1/4	16	213T	350
270	36-7/16	37-1/2	41-1/2	39-11/16	17-1/4	16	213T	400
300	40	38	42	44	17-1/4	16	213T	450
330	44	41-3/4	45-3/4	48-7/16	17-1/4	16	215T	500
365	46	42	46	50	17-1/4	16	215T	550
402	50-3/4	46-1/4	50-1/4	55-1/8	17-1/4	14	215T	650

ALL DIMENSIONS IN INCHES. WEIGHTS IN LBS. LESS MOTOR AND DRIVES.

ACCESSORIES

- SIDE DISCHARGE PACKAGE
- DUAL SIDE DISCHARGE PACKAGE
- DISCONNECT SWITCH
- BELT GUARD
- OSHA BELT GUARD
- MOTOR COVER (INDOOR USE ONLY)
- INSULATED HOUSING
- INLET/OUTLET FLEX DUCT CONNECTOR
- INLET GUARD
- OUTLET GUARD
- FLANGED INLET/FLANGED OUTLET
- INLET/OUTLET COMPANION FLANGE
- GRAVITY BACKDRAFT DAMPER
- MOTORIZED BACKDRAFT DAMPER
- ALUMINUM EXTERNAL INLET VANE DAMPER
- STEEL EXTERNAL INLET VANE DAMPER
- CEILING MOUNTED RUBBER IN SHEAR ISOLATORS
- FLOOR MOUNTED RUBBER IN SHEAR ISOLATORS
- CEILING MOUNTED SPRING ISOLATORS
- FLOOR MOUNTED SPRING ISOLATORS
- LORENIZED COATING

QTY	MARK	CATALOG NUMBER	FAN INFORMATION			MOTOR INFORMATION					ACCESSORIES	
			CFM	SP	RPM	HP	VOLTS	HZ	PH	TYPE		

ALL CATALOG ODP SINGLE SPEED MOTORS SHIP MOUNTED.
ALL OTHER MOTORS CONSULT FACTORY.